



FULL CONTROL BOARD MANUAL

https://www.bft-automation.com/grcodemanual/D814283

VIRGO BT B 20 KIT VIRGO BT B 20 KIT SLAVE



D814438 OADA0_02 18-03-25

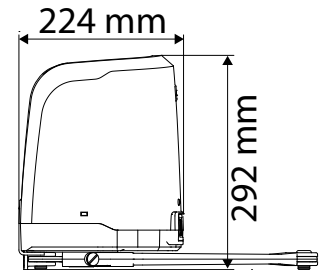
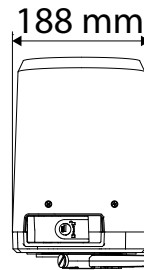
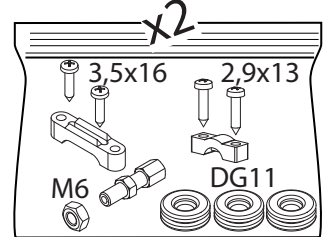
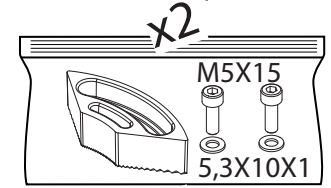
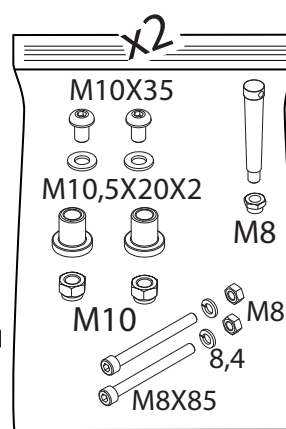
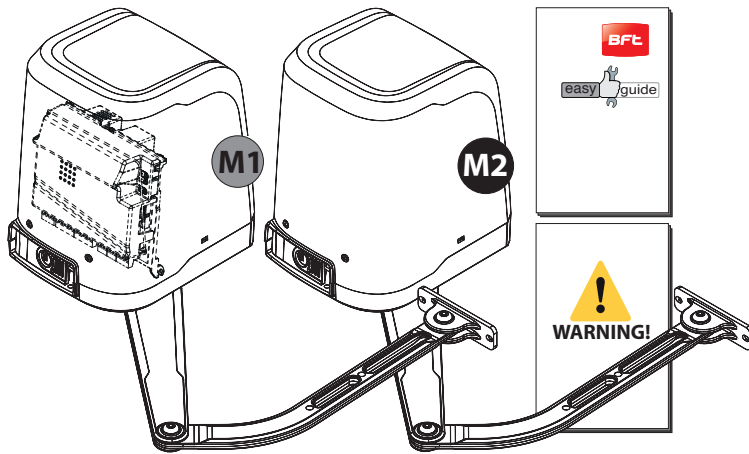

IT	Verifica la tua composizione nell'etichetta imballo.
EN	Check your composition on the packaging label
FR	Vérifiez votre composition sur l'étiquette d'emballage.
ES	Controla la composición de tu kit en la etiqueta del embalaje
DE	Überprüfen Sie Ihre Zusammenstellung auf dem Verpackungsetikett.
NL	Controleer uw samenstelling op het verpakingslabel.
PT	Verifique a composição no rótulo da embalagem
EL	Ελέγξτε τη σύνθεση του κιτ στην ετικέτα της συσκευασίας
PL	Prosimy sprawdzić zawartość zestawu na etykiecie opakowania"
RU	Проверьте комплектацию на этикетке упаковки.
CS	Zkontrolujte složení sady na štítku obalu.
TR	Ambalaj etiketindeki bileşiminizi kontrol edin
HR	Na etiketi provjerite sastav svojeg paketa
RO	Verificați-vă compoziția de pe eticheta ambalajului
AR	تحقق من التركيبة لي ماصق العبوة

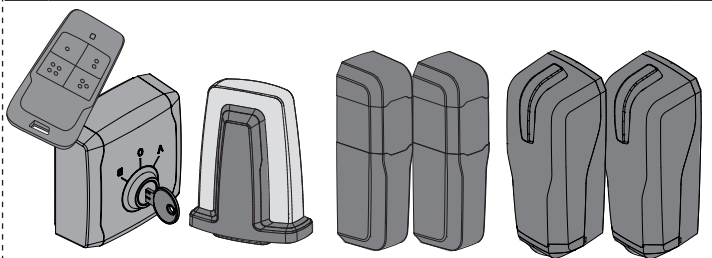

	M1	M2 SLAVE
	220-230 V 50/60 Hz	/
P stand-by	0,48 W	/
Pmax	110 W	40 W
	433,92 MHz	
IP	44	
	-20°C / +60°C	
cycles/h	30	
	<70 dBA	
Speed max	6°/s	

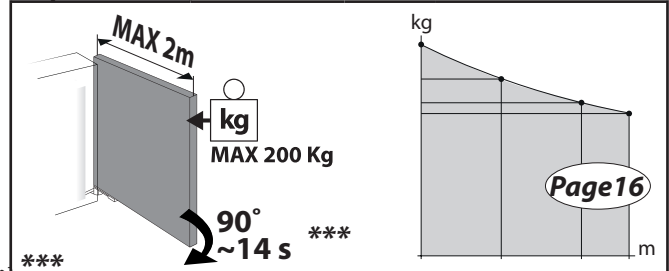

*** EN: Tempo indicativo misurato senza rallentamenti (anta massima e peso massimo).
 EN: Indicative time measured without slowdowns (maximum door and maximum weight).
 FR: Temps indicatif mesuré sans ralentissements (vantail maximum et poids maximum).
 DE: Gemessene Richtzeit ohne Abbremsen (maximaler Flügel und maximales Gewicht).
 ES: Tiempo orientativo medido sin ralentizaciones (puerta máxima y peso máximo).
 NL: Indicatieve tijd gemeten zonder vertragingen (maximale vleugel en maximaal gewicht).
 PT: Tempo indicativo medido sem desacelerações (porta máxima e peso máximo).
 GR: Ενδεικτικός χρόνος μετρημένος χωρίς επιβραδύνσεις (μέγιστο φύλλο και μέγιστο βάρος).
 PL: Orientacyjny czas mierzony bez spowolnień (maksymalne skrzydło i maksymalna waga).
 RU: Ориентировочное время, измеренное без замедлений (максимальная створка и максимальный вес).
 CZ: Orientační čas měřený bez zpomalení (maximální křídlo a maximální hmotnost).
 TR: Yavaşlama olmadan ölçülen gösterge süre (maksimum kanat ve maksimum ağırlık).
 HR: Indikativno vrijeme izmjereno bez usporavanja (maksimalni list i maksimalna težina).
 RO: Timp orientativ măsurat fără încetiniri (frunză maximă și greutate maximă).
 AR: تم قياس الوقت الاسترشادي بدون تباطؤ (الحد الأقصى للباب والوزن الأقصى)

Example

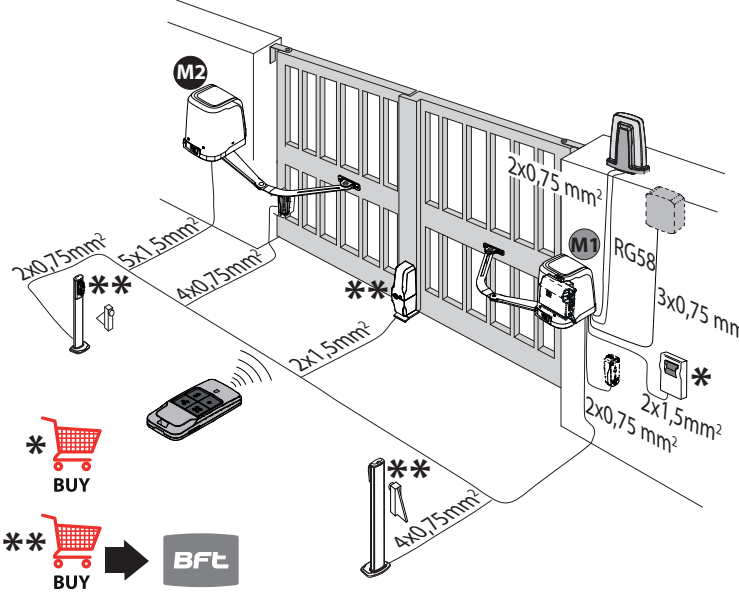

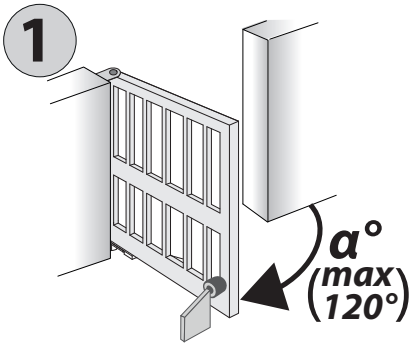

		A mm												
		128,5	140	150	160	170	180	190	200	210	220	230	240	250
B mm	30	90°	92°	95°	100°	102°	105°	107°	110°	112°	115°	118°	120°	
	40	90°	92°	95°	100°	102°	105°	107°	110°	112°	115°	115°	118°	
	50	90°	92°	95°	100°	102°	105°	107°	110°	110°	110°	115°	115°	
	60	90°	92°	95°	100°	102°	105°	107°	107°	110°	110°	115°	115°	
	70	90°	92°	95°	97°	100°	102°	107°	107°	110°	110°	112°	115°	
	80	90°	92°	95°	97°	100°	102°	105°	107°	107°	110°	110°	112°	
	90	90°	92°	95°	97°	100°	102°	105°	107°	107°	110°	112°	112°	
	100	90°	92°	95°	97°	100°	102°	105°	105°	107°	110°	112°	112°	
	110	90°	92°	95°	97°	100°	102°	102°	105°	107°	107°	110°	112°	
	120	90°	92°	95°	97°	100°	100°	102°	105°	107°	107°	110°	112°	
	130	90°	92°	95°	97°	100°	100°	102°	105°	105°	107°	110°		
	140	90°	92°	92°	97°	97°	100°	102°	105°	105°	107°			
	150	90°	90°	92°	97°	97°	100°	102°	102°	105°				
	160	90°	90°	92°	95°	97°	100°	100°	102°					
	170	90°	90°	92°	95°	97°	100°	100°						
	180	90°	90°	92°	95°	97°	100°							
	190	90°	90°	92°	95°	97°								
200	90°	90°	92°	95°										
210	90°	90°	92°	95°										
220	90°	90°	92°											
230	90°	90°												
235	90°													

α°

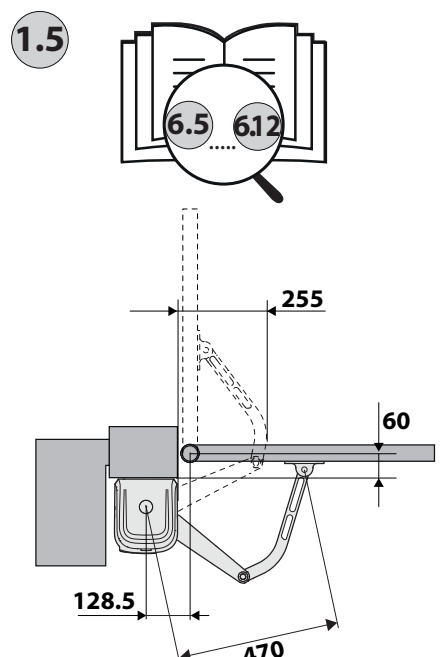
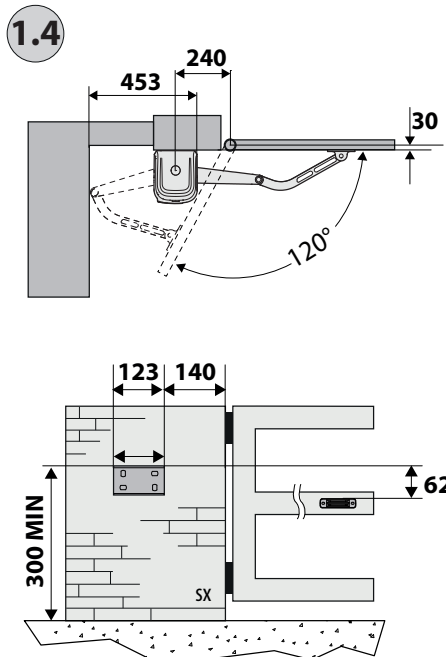
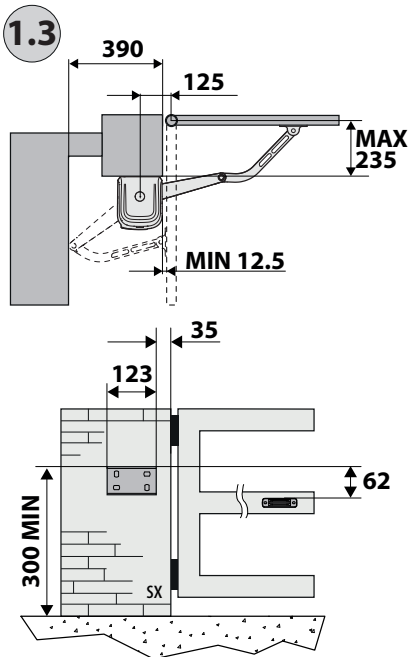
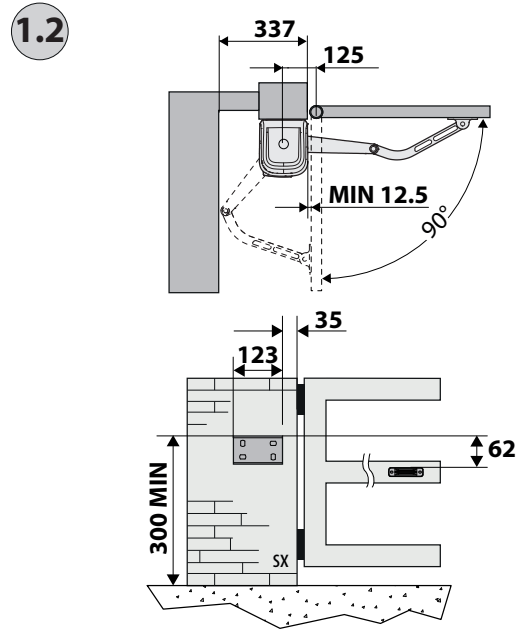
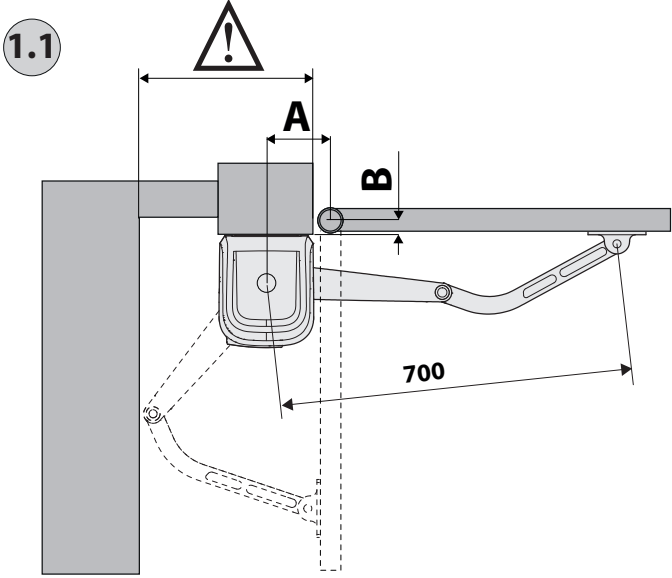

2

2.1

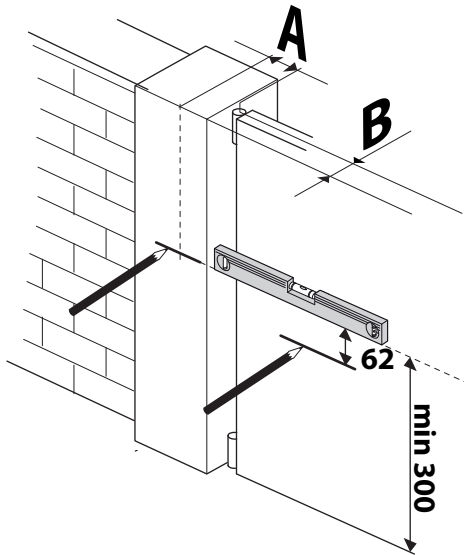

2.2

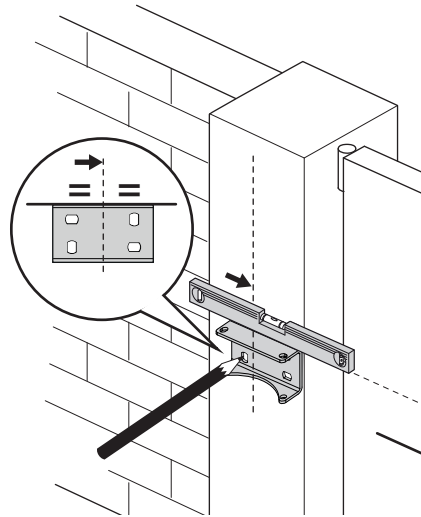

2.3

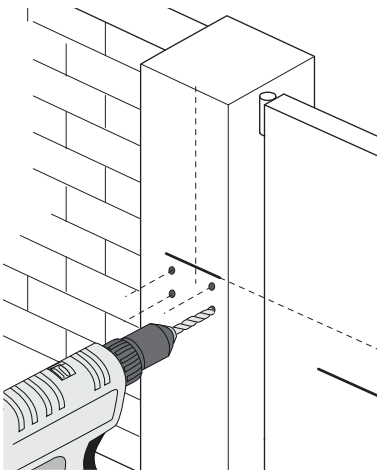

2.4

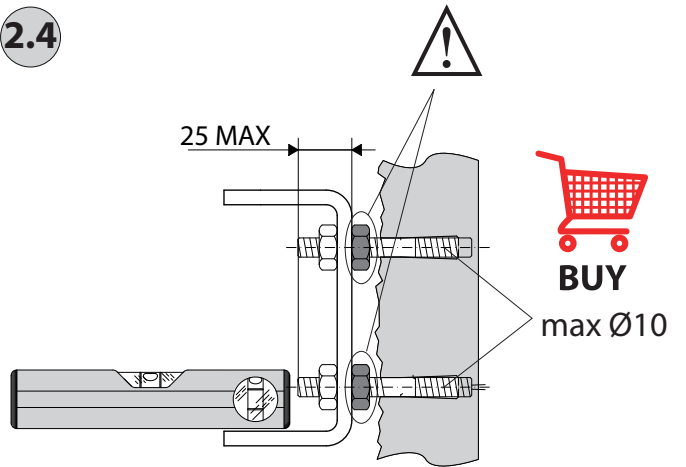

3

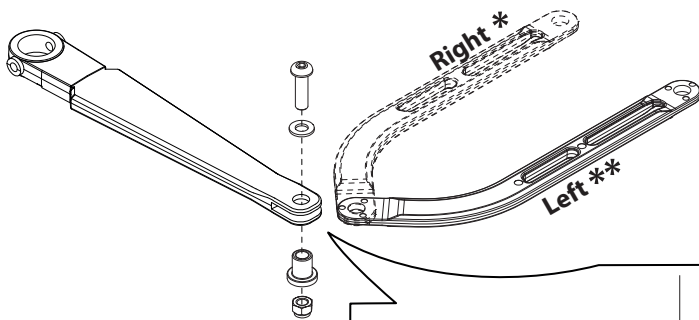
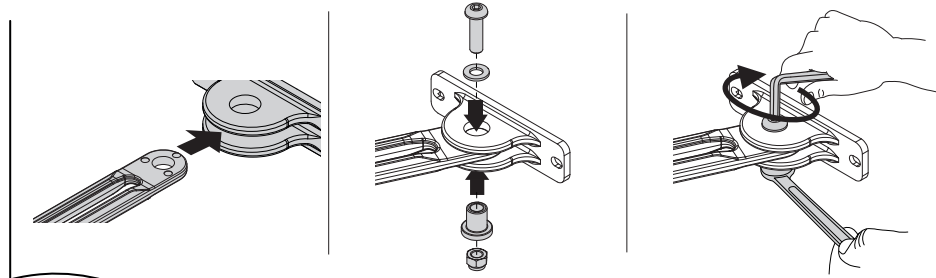

* Destra
 Right
 Droite
 Rechts
 Derecha
 Rechts
 Direita
 Δεξιά
 Prawa
 Πραβο
 Vpravo
 Sağ
 Desno
 Dreapta

** Sinistra
 Left
 Gauche
 Links
 Izquierda
 Links
 Esquerda
 Αριστερά
 Lewa
 Лево
 Vlevo
 Sol
 Lijevo
 Stânga

اليمين

اليسار

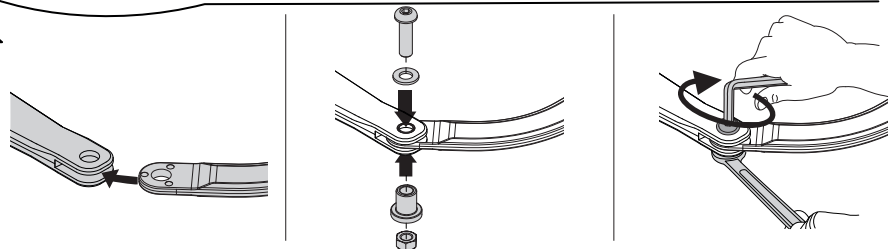

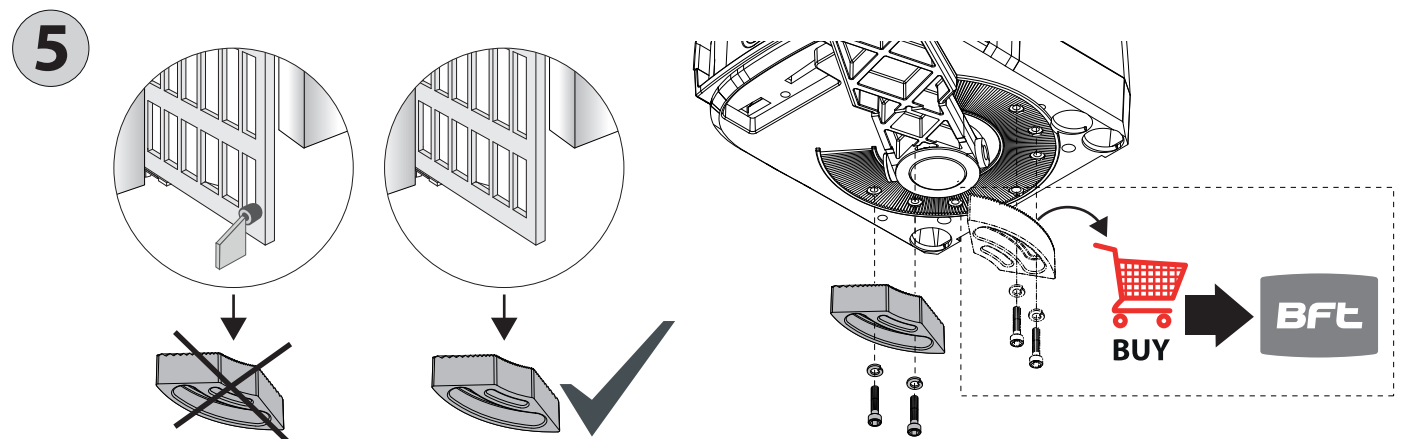
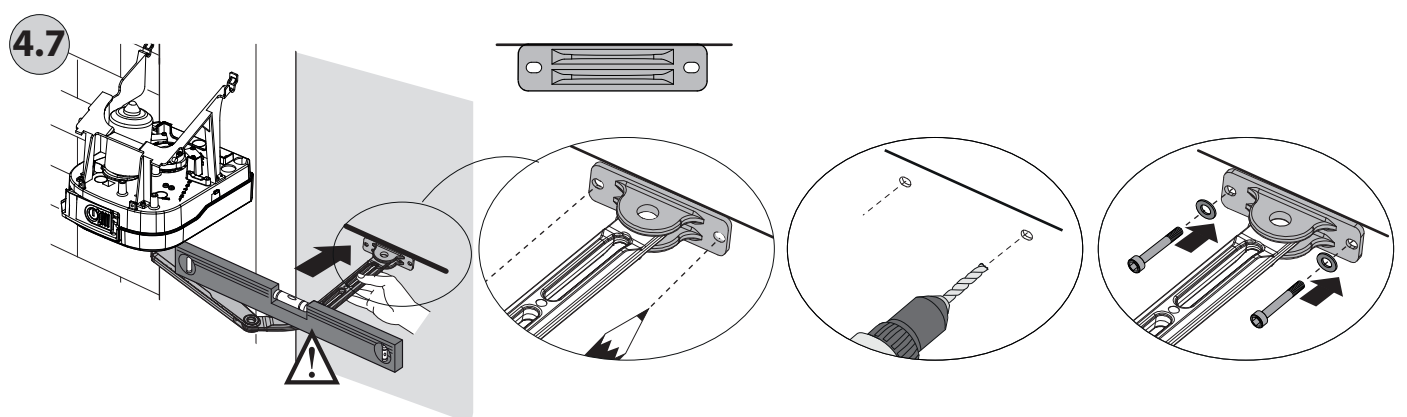
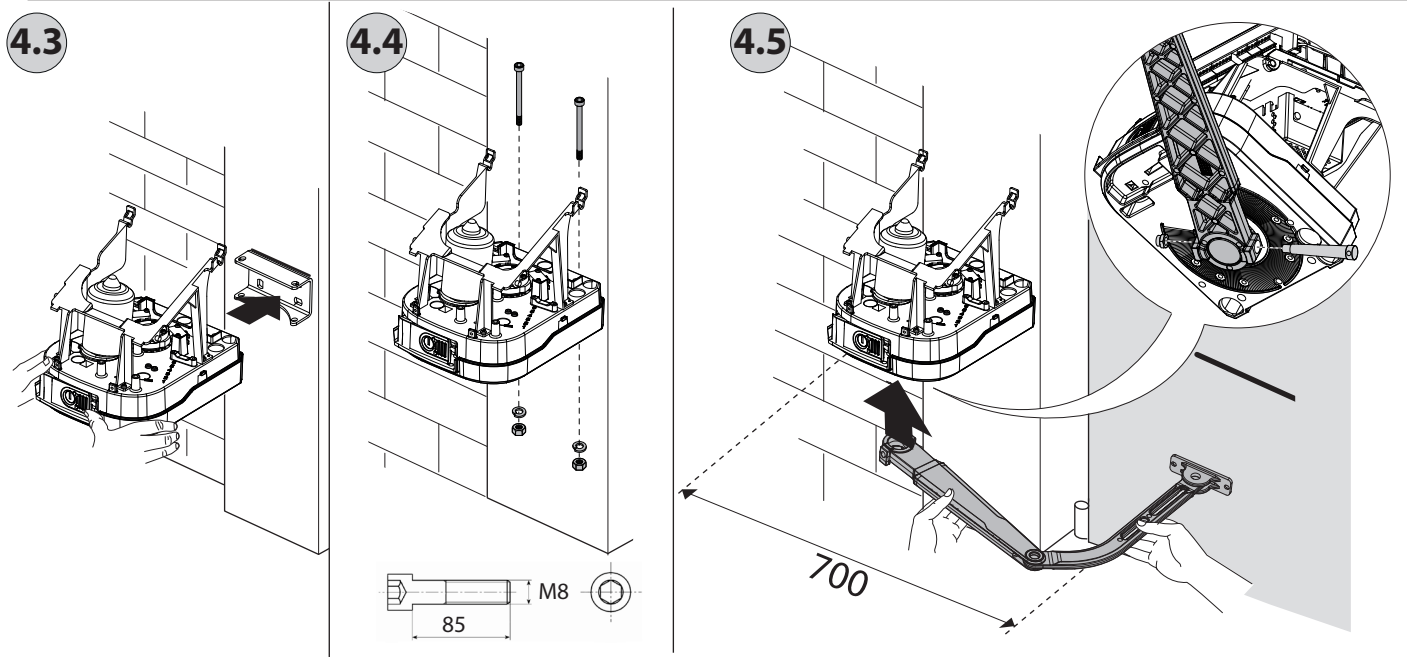
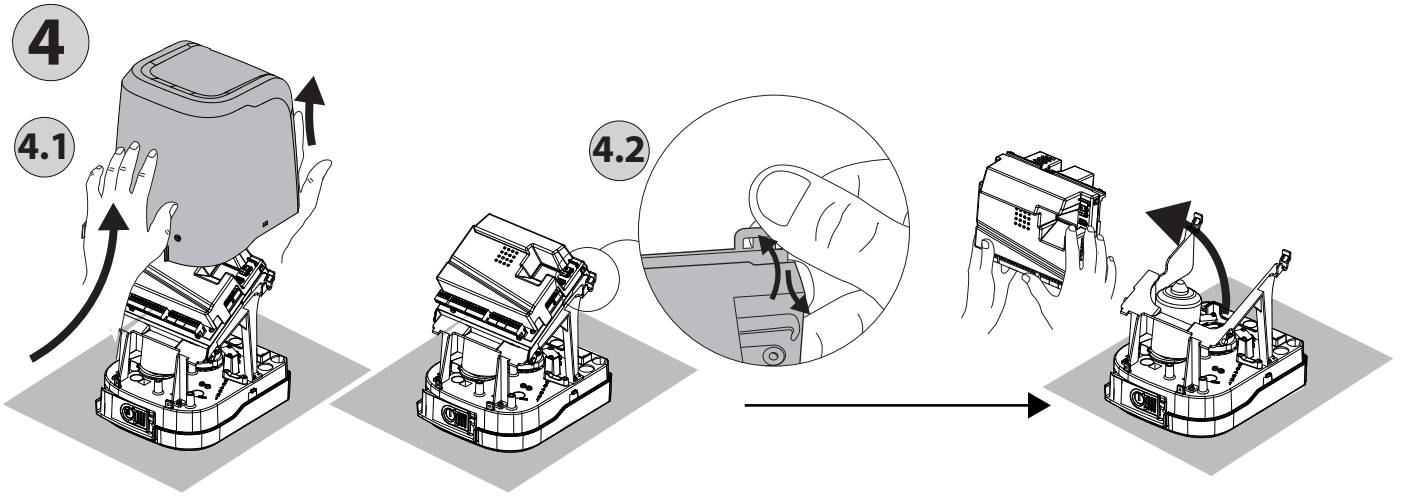

6

REGOLAZIONE FINECORSO, LIMIT DEVICE ADJUSTMENT,
 RÉGLAGE DES FINS DE COURSE, EINSTELLUNG DES ENDSCHALTERS,
 REGULACIÓN DEL FIN DE CARRERA, AFSTELLING EINDAANSLAG,
 REGULAÇÃO FIM DE CURSO, ΡΥΘΜΙΣΗ ΤΕΡΜΑΤΙΚΩΝ,
 REGULACJA WYŁĄCZNIKÓW KRAŃCOWYCH
 РЕГУЛИРОВКА КОНЦЕВОГО ВЫКЛЮЧАТЕЛЯ, SEŘÍZENÍ KONCOVÉHO SPÍNAČE,
 LÍMIT SVÍCINÍN AYARLANMASI, PODEŠAVANJE GRANIČNOG PREKIDAČA,
 SETAREA COMUTATORULUI DE LIMITĂ, الحد من تعديل التبدیل

 **example 6.4**

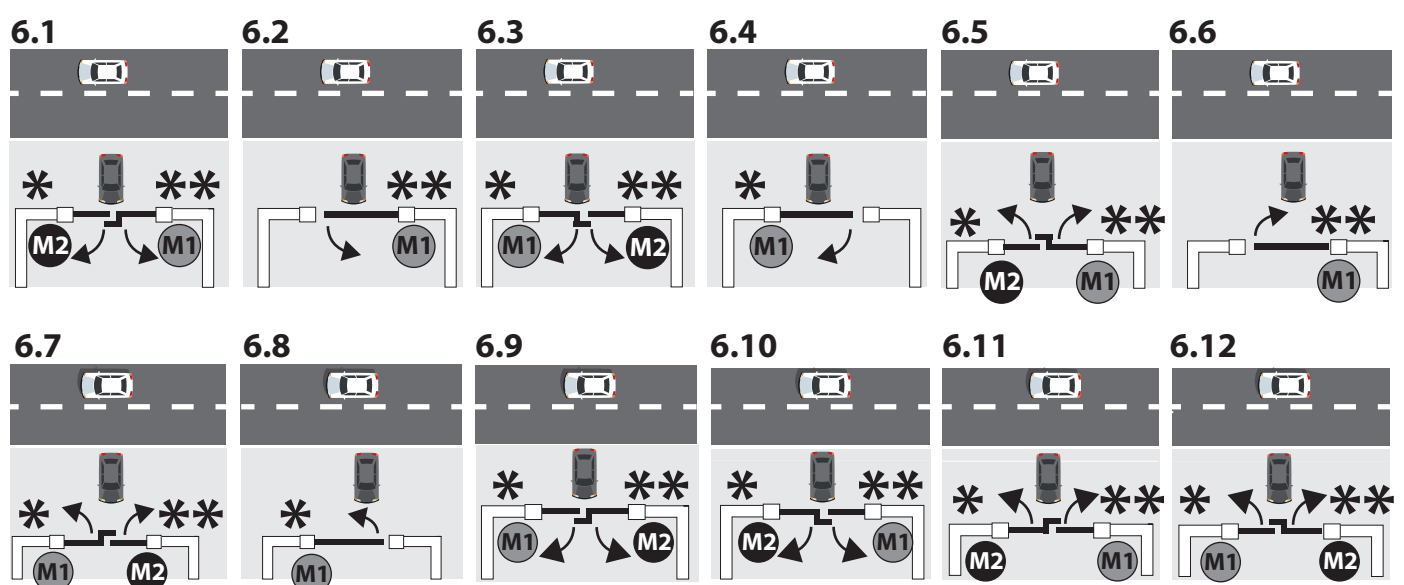
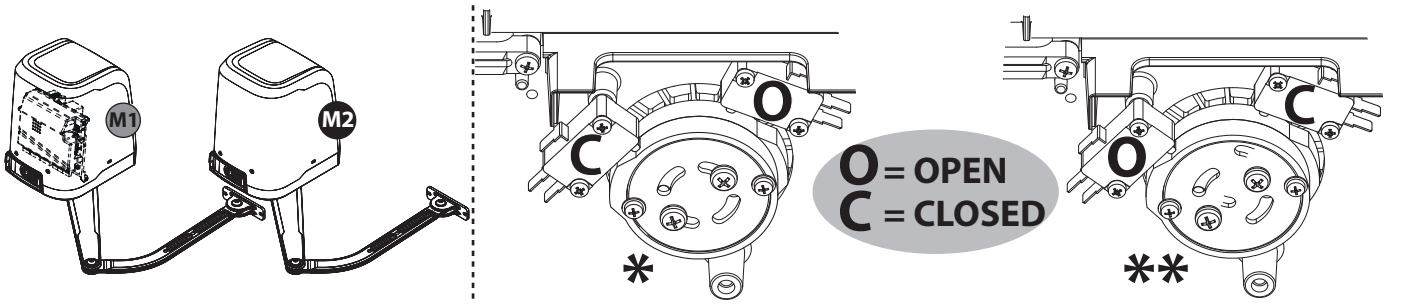
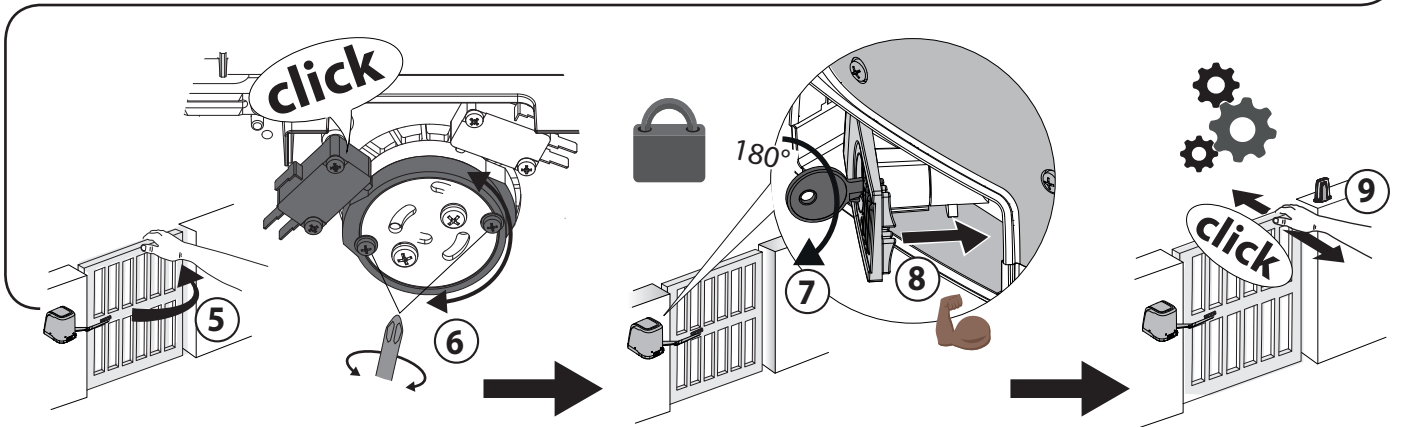
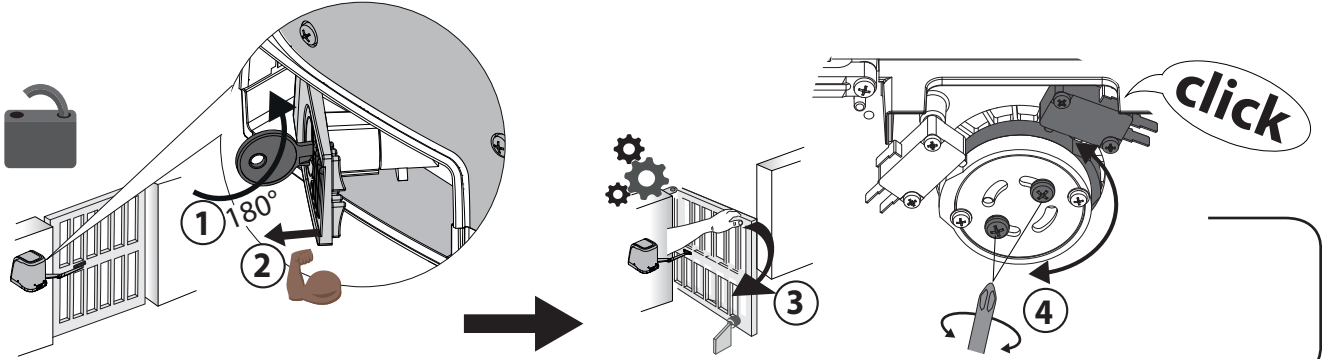
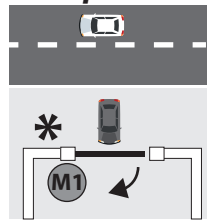

7

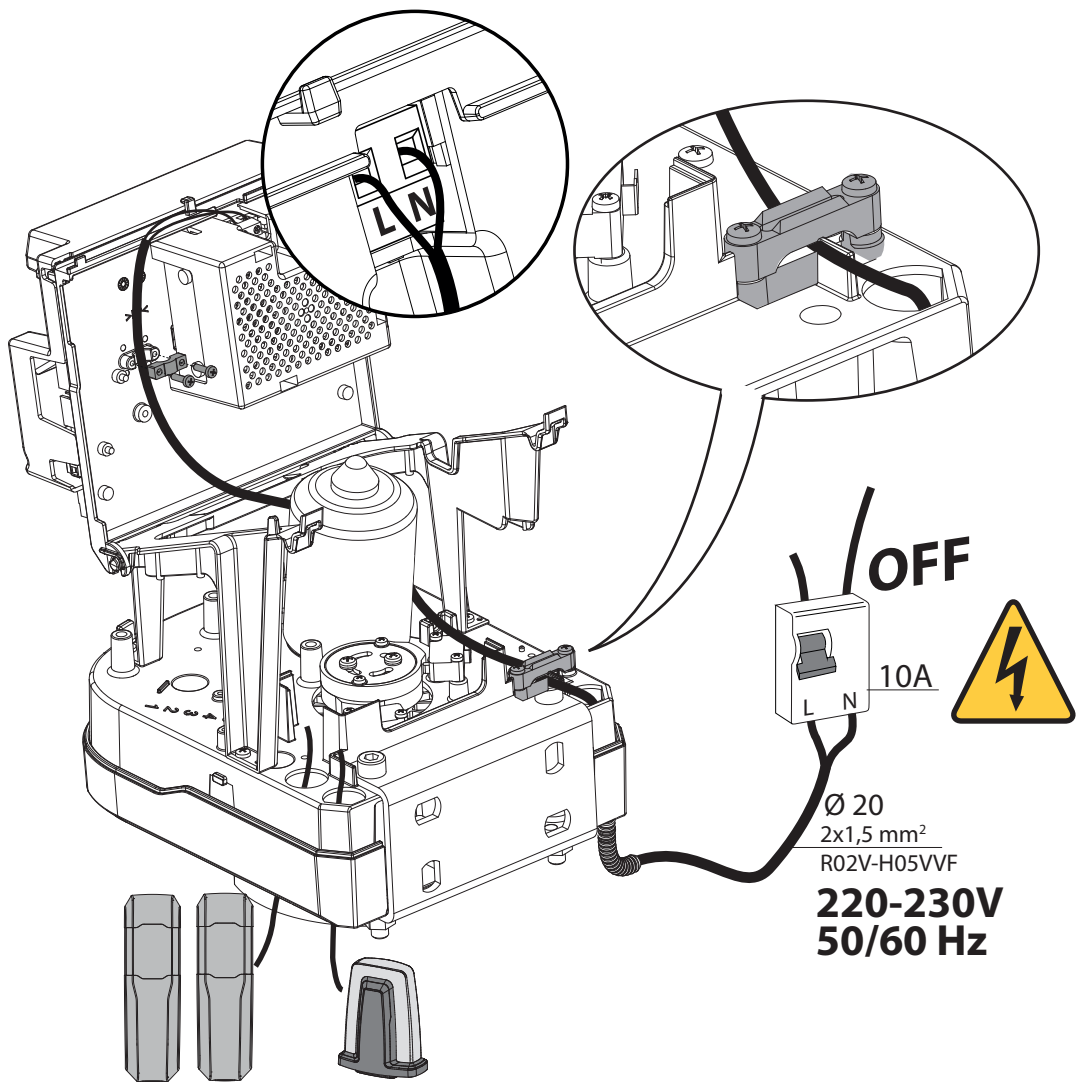
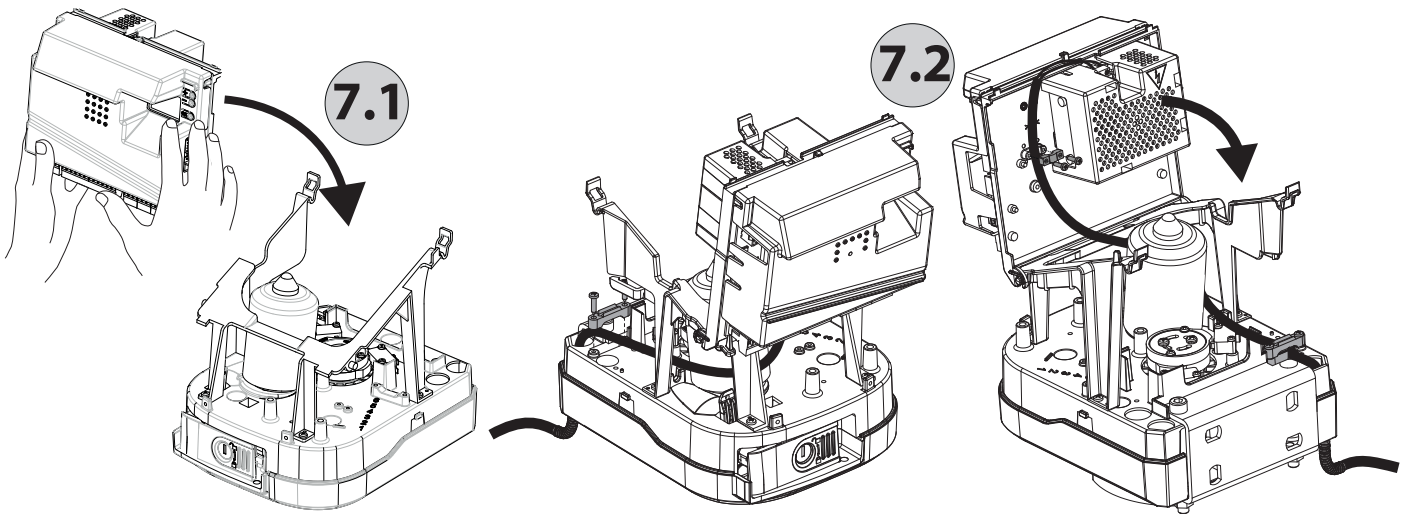

M1

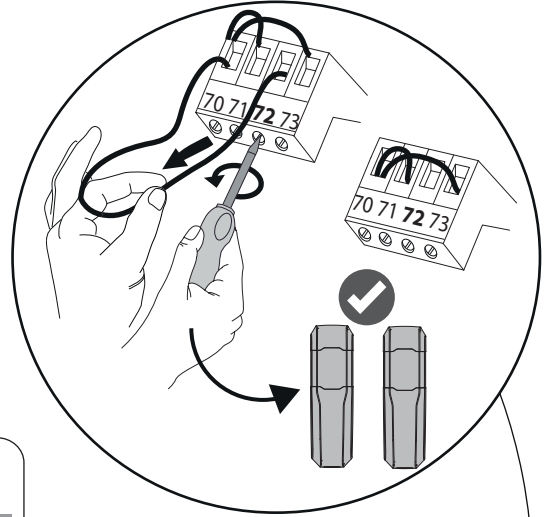

Warning: COM ≠ COM IC

70 COM
69 COM IC

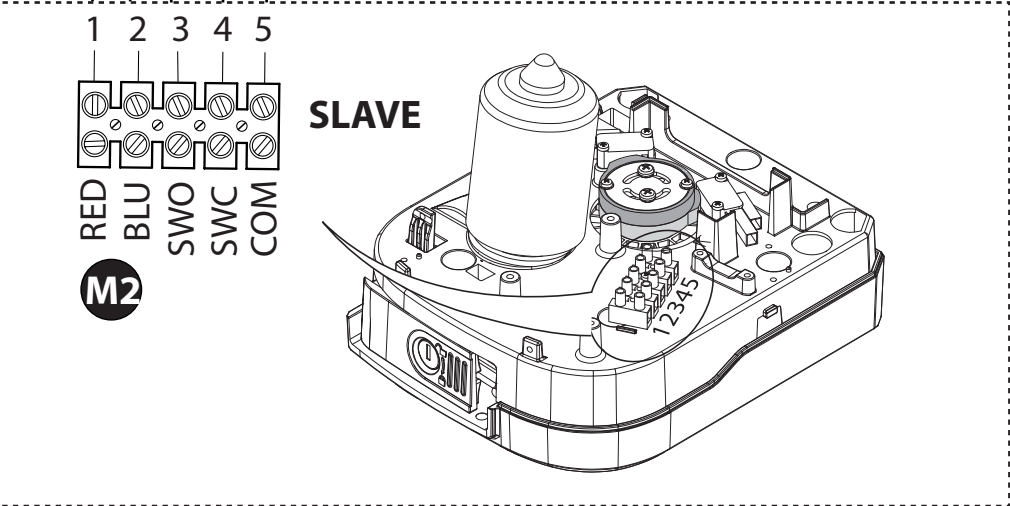
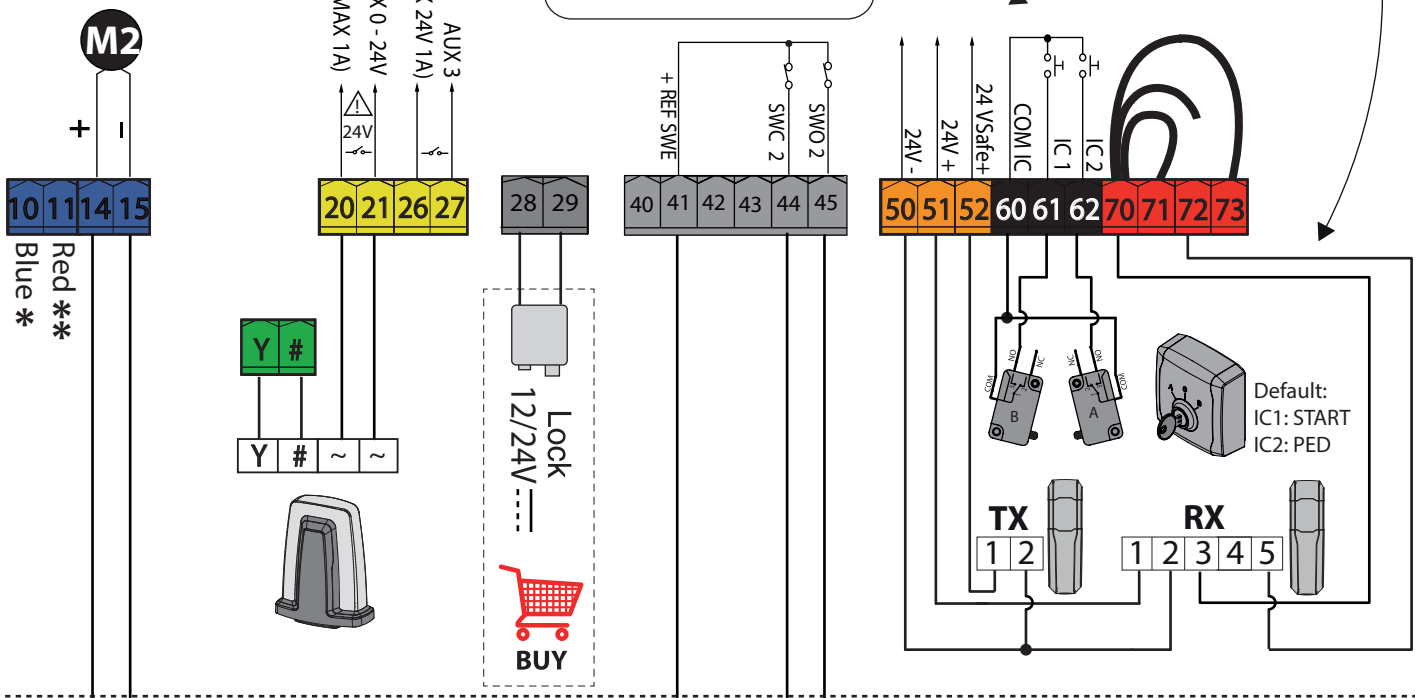

	*	**
IT	Blu	Rosso
EN	Blue	Red
FR	Bleu	Rouge
DE	Blau	Rot
ES	Azul	Rojo
NL	blauw	Rood
PT	Azul	Vermelho
EL	Μπλε	κόκκινο
PL	niebieski	czerwony
RU	синий	красный
CS	modro	červený
TR	mavi	kırmızı
HR	plava	Crvena
RO	albastru	roșu
AR	أزرق	أحمر

8

**MENÙ SEMPLIFICATO - SIMPLIFIED MENU - MENU SIMPLIFIÉ -
VEREINFACHTES MENÜ - MENÙ SEMPLIFICADO - VEREENVUODIGD MENU -
MENU PROGRAMAÇÃO INSTALAÇÃO - ΜΕΝΟΥ ΡΥΘΜΙΣΗΣ ΕΓΚΑΤΑΣΤΑΣΗΣ -
MENU USTAWIEŃ INSTALACJI - МЕНЮ УСТАНОВКИ ОБОРУДОВАНИЯ - MENU PRO NASTAVENÍ
ZAŘÍZENÍ - TESİSİ AYARLAMA MENÜSÜ -
ПОЈЕДНОСТАВЉЕНИ ИЗБОРНИК - ZJEDNODUŠENÉ MENU - القائمة المبسطة**

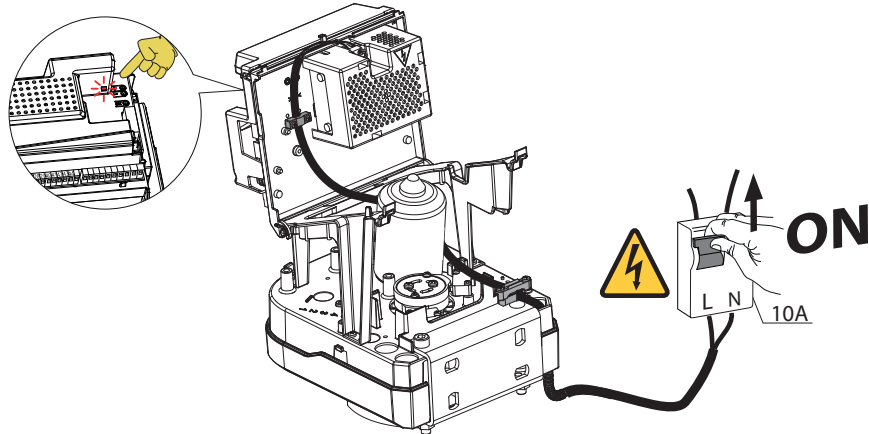

**LEGENDA - LEGENDE - LEGEND - LEYENDA - ΥΠΟΜΝΗΜΑ -
УСЛОВНЫЕ ОБОЗНАЧЕНИЯ - ANLAMLAR - أسطورة**

C

IT	Cancello chiuso
EN	Gate closed
FR	portail fermé
ES	puerta cerrada
DE	Tor geschlossen
NL	hek gesloten
PT	portão fechado
EL	πύλη κλειστή
PL	brama zamknięta
RU	закрытые ворота
CS	brána zavřena
TR	kapı kapalı
HR	Vrata zatvorena
RO	Barieră închisă
	البوابة مغلقة AR

PrG

IT	Salvataggio in corso
EN	Saving
FR	sauvegarde en cours
ES	copia de seguridad en curso
DE	Backup läuft
NL	back-up wordt uitgevoerd
PT	backup em curso
EL	δημιουργία αντιγράφων ασφαλείας σε εξέλιξη
PL	wykonywanie kopii zapasowej w toku
RU	выполняется резервное копирование
CS	probíhá zálohování
TR	yedekleme devam ediyor
HR	Spremanje
RO	Salvare
	حفظ AR

O

IT	Cancello aperto
EN	Gate opened
FR	portail ouvert
ES	puerta abierta
DE	Tor offen
NL	hek geopend
PT	portão aberto
EL	πύλη ανοιχτή
PL	brama otwarta
RU	открытые ворота
CS	brána otevřena
TR	kapı açık
HR	Vrata otvorena
RO	Barieră deschisă
	البوابة مفتوحة AR



IT	Azione da fare rapidamente
EN	To do quickly
FR	action à faire rapidement
ES	la acción se debe realizar rápidamente
DE	Maßnahme schnell durchzuführen
NL	moet snel worden uitgevoerd
PT	ação a executar rapidamente
EL	ενέργεια που πρέπει να γίνει γρήγορα
PL	działania, które należy podjąć szybko
RU	быстро выполняемая операция
CS	akce, která má být provedena rychle
TR	hızlı bir şekilde gerçekleştirilecek eylem
HR	Brzo učiniti
RO	A se efectua rapid
	القيام بسرعة AR

Display in italiano

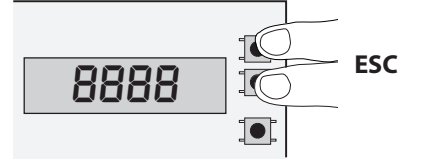
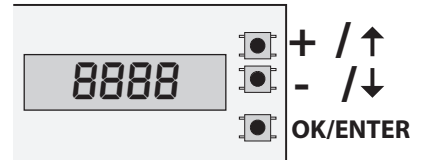
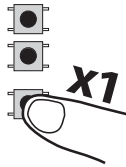

(IT) Lingua - (PT) Língua

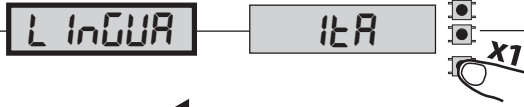

(IT) Tipo motore - (PT) Tipo de motor

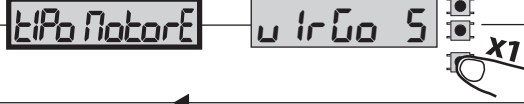

(IT) Numero motori - (PT) Número de motores

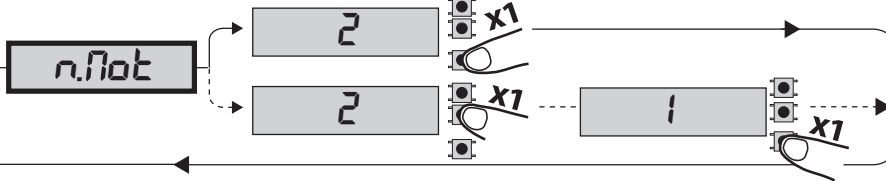

(IT) Direzione - (PT) Direção



(IT) Personalizzazione - (PT) Personalização

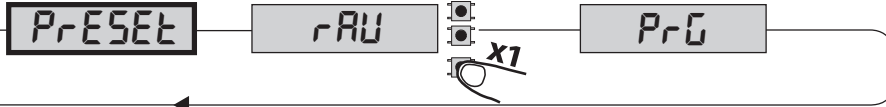

(IT) Memorizzazione dei telecomandi
(PT) Memorização dos comandos por rádio

IT Ripetere l'operazione se ci sono altri telecomandi
PT Repetir a operação se houver outros comandos por rádio

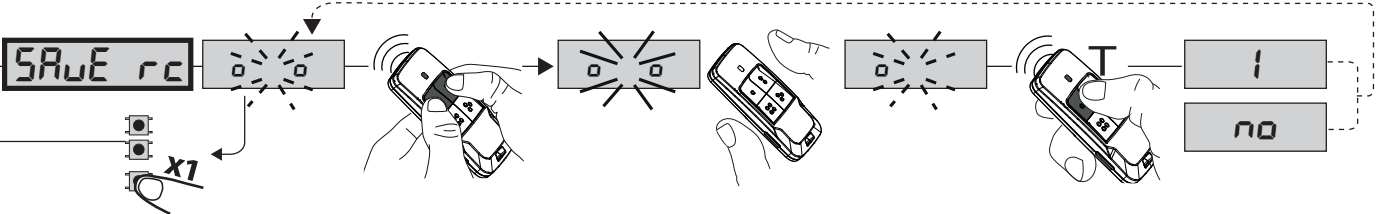

(IT) Regolazione finecorsa - (PT) Regulación de final de carrera



(IT) Regolazione automatico della forza - (PT) Regulação automática da força

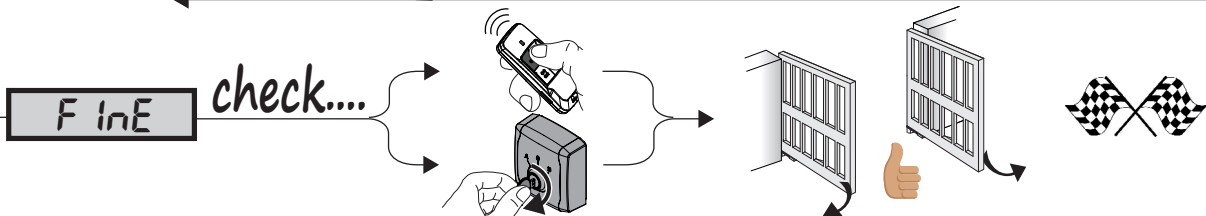
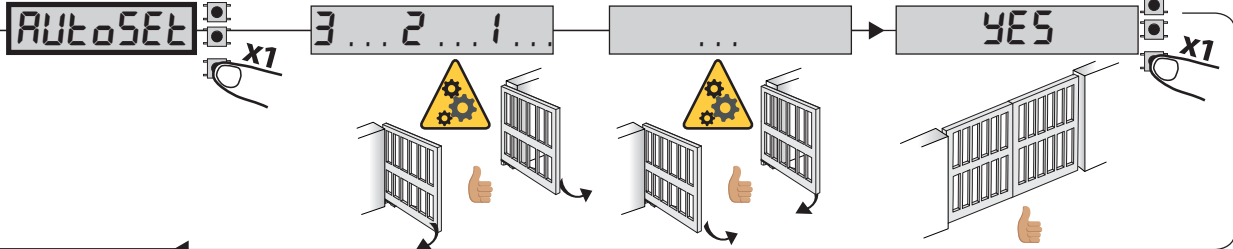

Display in English

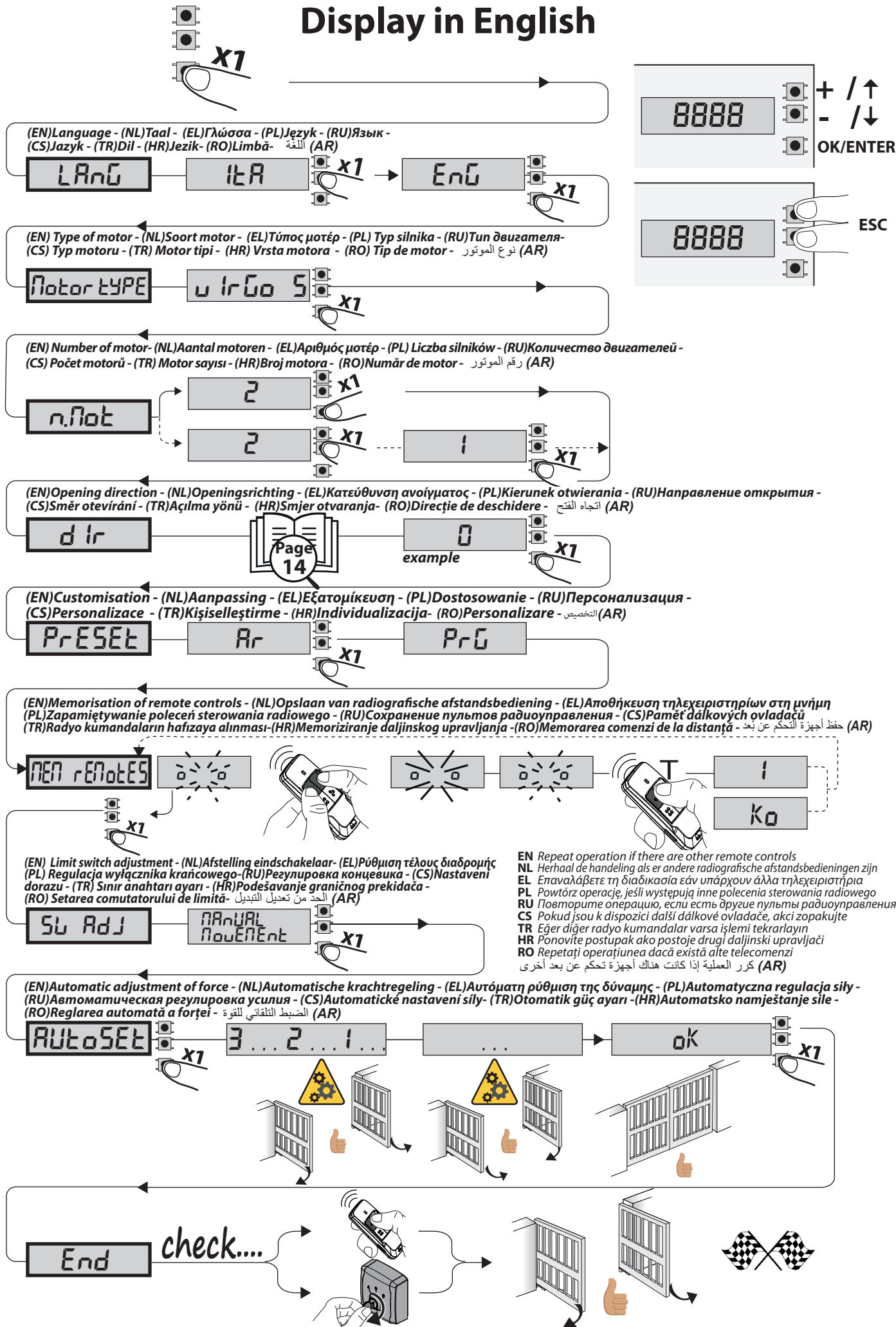

EN Repeat operation if there are other remote controls
NL Herhaal de handeling als er andere radiografische afstandsbedieningen zijn
EL Επαναλάβετε τη διαδικασία εάν υπάρχουν άλλα τηλεχειριστήρια
PL Powtórz operację, jeśli występują inne polecenia sterowania radiowego
RU Повторите операцию, если есть другие пульты радиоуправления
CS Pokud jsou k dispozici další dálkové ovladače, akci zopakujte
TR Eğer diğer radyo kumandalar varsa işlemi tekrarlayın
HR Ponovite postupak ako postoje drugi daljinski upravljači
RO Repetați operațiunea dacă există alte telecomenzi
(AR) كرر العملية إذا كانت هناك أجهزة تحكم عن بعد أخرى

Afficheur en français

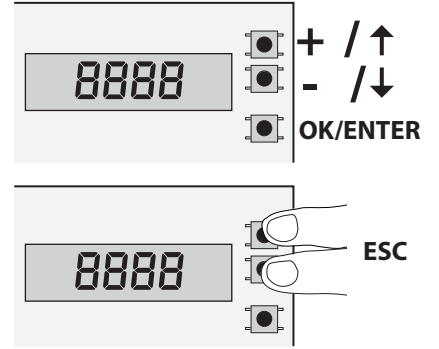
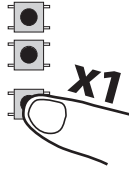

Langue

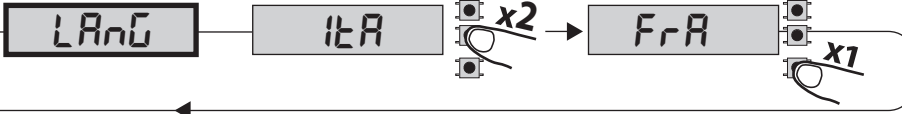

Type de moteur

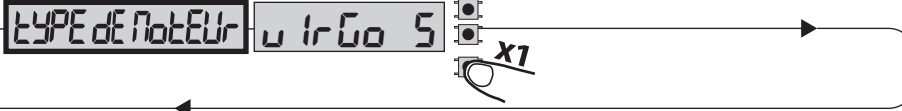

Nombre de moteurs

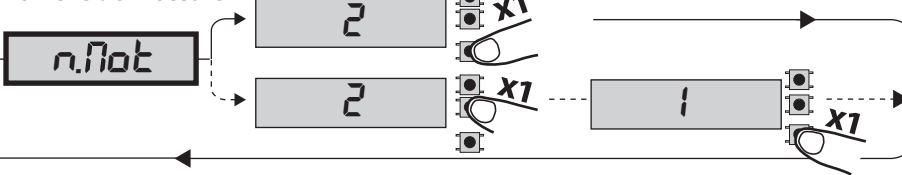

Direction d'ouverture



Personnalisation

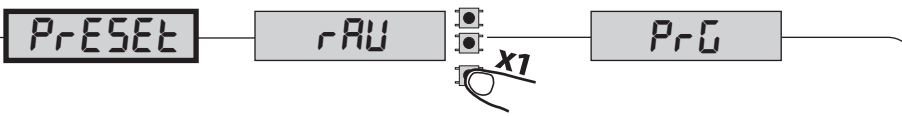

Mémorisation des télécommandes

Répète l'opération si d'autres télécommandes

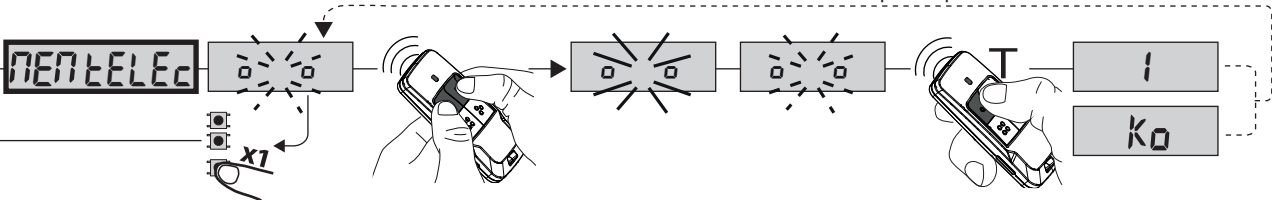

Réglage des fins de course



Réglage automatique de la force

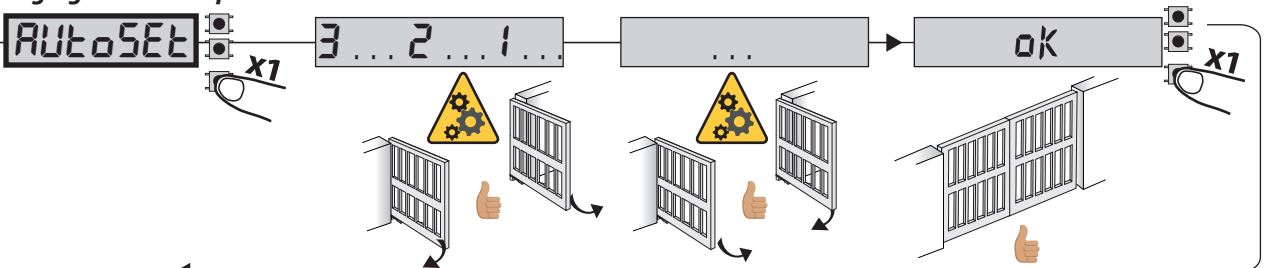

Fin

check....

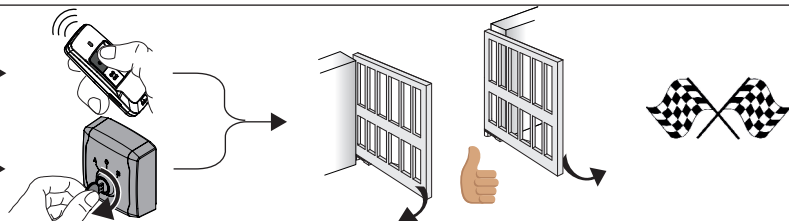

Menú en español

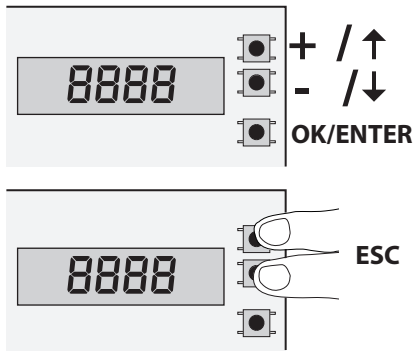
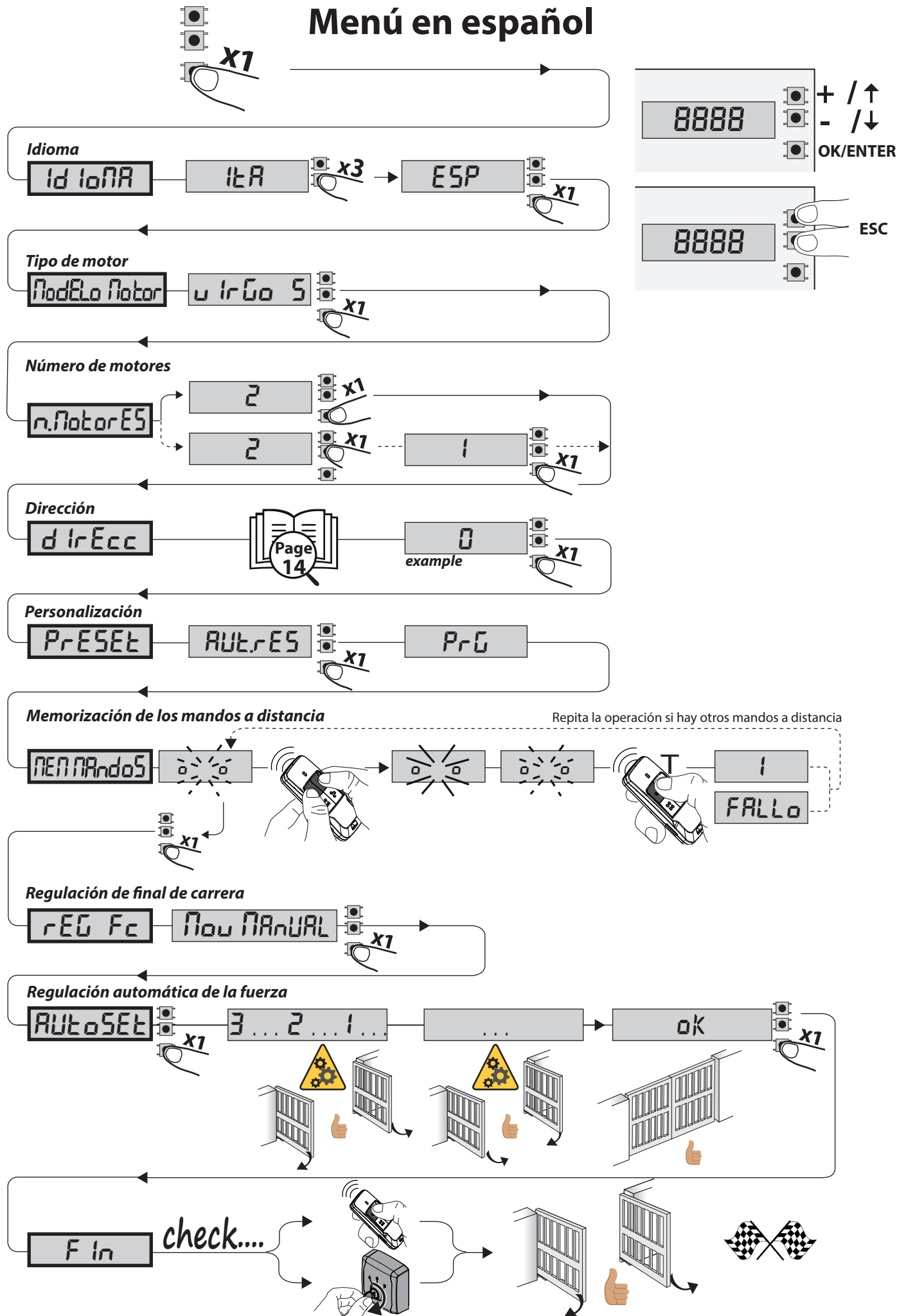

Auswahlmenü auf Deutsch

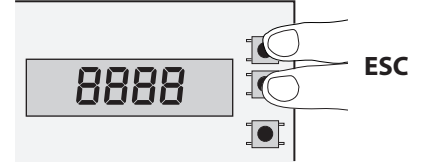
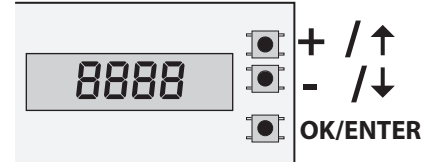
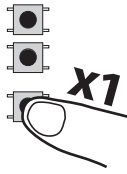

Sprache

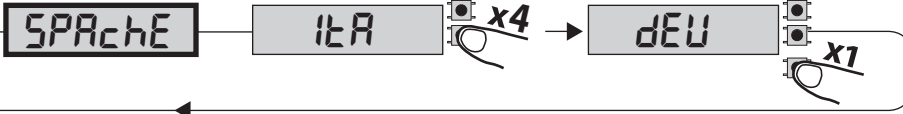

Motortyp

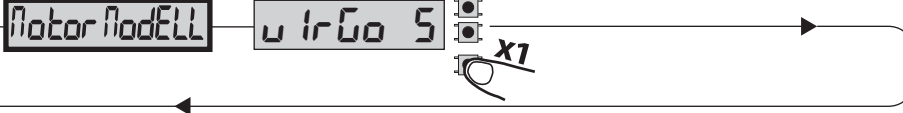

Anzahl der Motoren

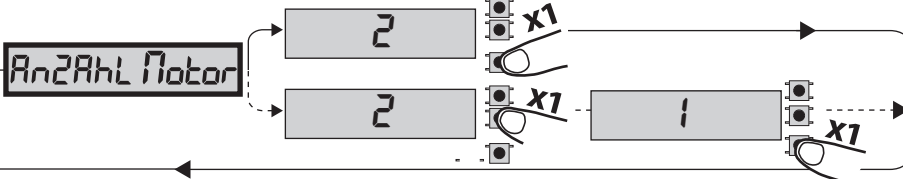

Öffnungsrichtung



Personalisierung

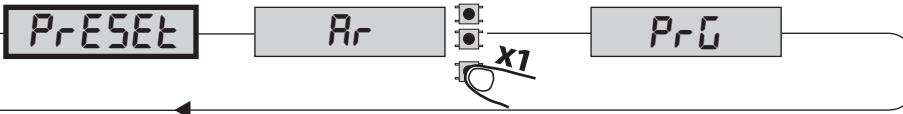

Speicherung der Fernbedienungen

Wiederholen Sie den Vorgang, wenn weitere Fernbedienungen vorhanden sind

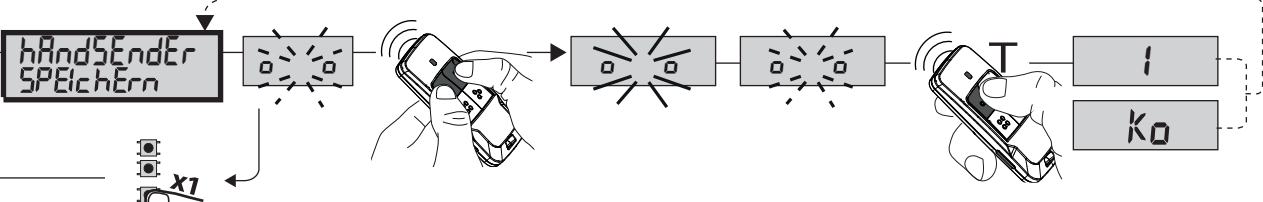

Einstellung des Endschalters



Speicherung der Fernbedienungen

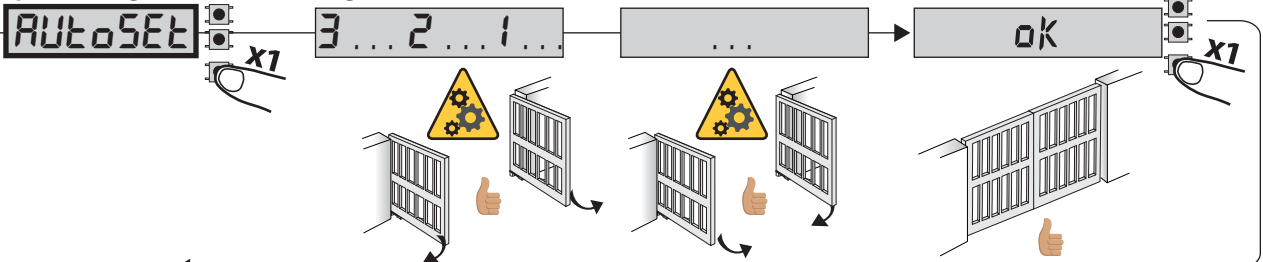

EndE

check....

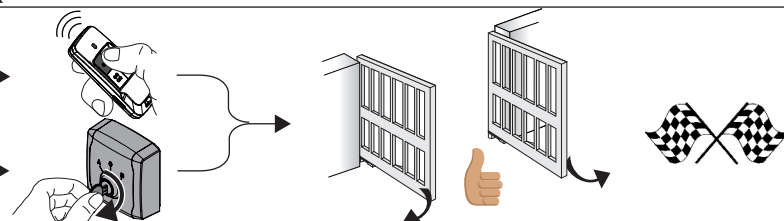

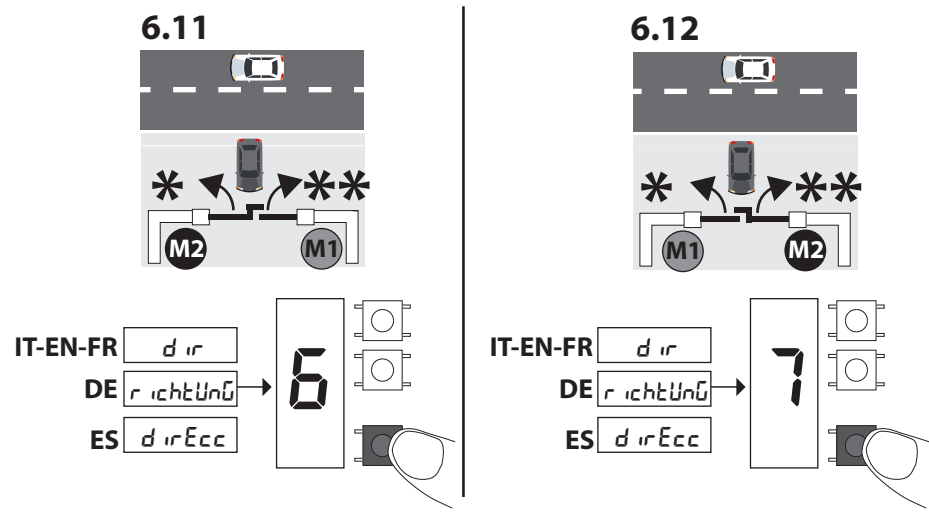
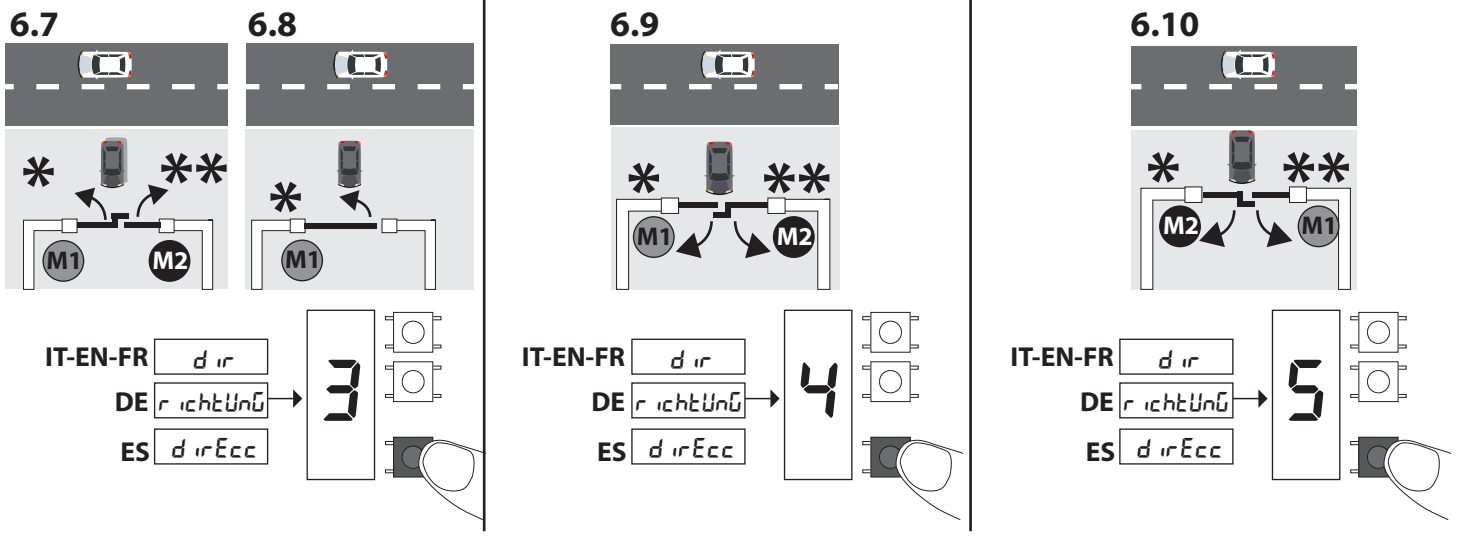
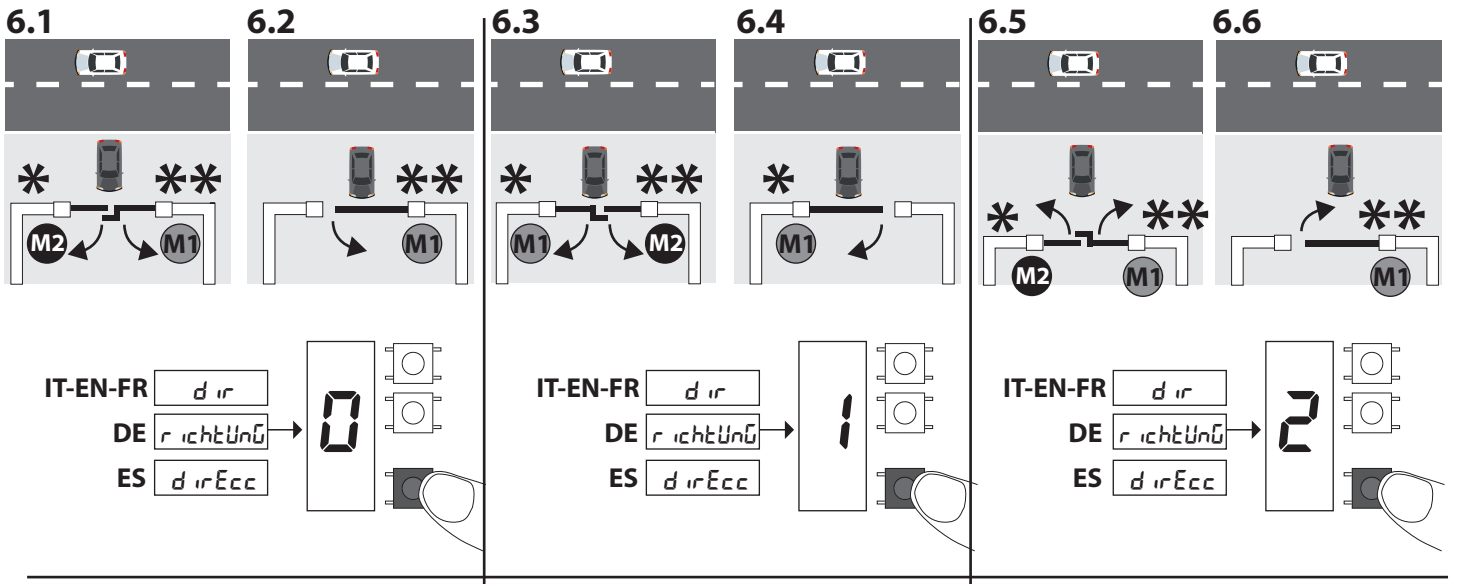

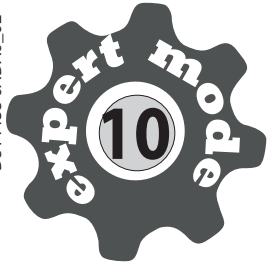

tca

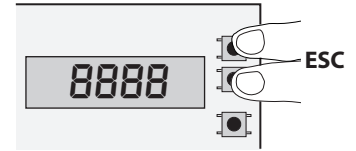
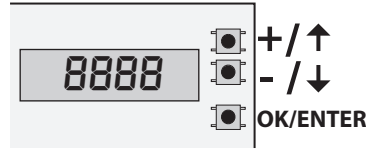

LEGENDA - LEGENDE - LEGEND - LEYENDA - ΥΠΟΜΝΗΜΑ - LEGANDA - ЛЕЗАНТА - УСЛОВНЫЕ ОБОЗНАЧЕНИЯ - VYSVĚTLIVKY - ANLAMLAR - LEGENDÄ - أسطورة



(IT)Premere 2 volte rapidamente sul tasto OK - (EN) Press the OK button 2 times in quick succession - (FR)Appuyer 2 fois rapidement sur la touche OK
(ES)Pulse rápidamente el botón OK 2 veces - (DE)Drücken Sie 2 Mal schnell die Taste OK - (NL)Druk 2 keer snel op de knop OK
(PT) Premir rapidamente no botão OK 2 vezes - (EL)Πατήστε γρήγορα το κουμπί OK 2 φορές - (PL)Naciśnij szybko przycisk OK 2 razy (RU)Быстро нажмите кнопку OK 2 раза - (CS)Stiskněte tlačítko OK 2krát v rychlém sledu - (TR)2 kez hızlı bir şekilde OK düğmesine basın
(HR) Tipku OK redu brzo pritisnite 2 puta zaredom.-(RO) Apăsăți butonul OK de 2 ori în succesiune rapidă - (AR) اضغط على زر موافق 2 مرات في تعاقب سريع



(IT)premere finché compare il parametro desiderato - (EN) press until the desired parameter appears - (FR)appuyer jusqu'à voir le paramètre désiré
(ES)Pulse hasta que aparezca el parámetro deseado - (DE)drücken, bis der gewünschte Parameter erscheint - (NL)druk tot de gewenste parameter verschijnt
(PT) premir até encontrar o parâmetro desejado - (EL)πατήστε μέχρι να εμφανιστεί η επιθυμητή παράμετρος
(PL)naciskaj do momentu pojawienia się żądanego parametru - (RU)удерживайте до появления желаемого параметра
(CS)tiskněte, dokud se nezobrazí požadovaný parametr - (TR)istenen parametre görülene kadar basın - (HR) pritiščite sve dok se ne pojavi željeni parametar - (RO) apăsați până când apare parametrul dorit - (AR) اضغط حتى تظهر المعلمة المطلوبة

PrG

(IT)Programmazione - (EN) Programming - (FR)Sauvegarde en cours - (ES)Copia de seguridad en curso - (DE)Backup läuft - (NL)back-up wordt uitgevoerd
(PT) backup em curso - (EL)δημιουργία αντιγράφων ασφαλείας σε εξέλιξη - (PL)wykonywanie kopii zapasowej w toku - (RU)выполняется резервное копирование - (CS)probíhá zálohování - (TR)yedekleme devam ediyor - (HR) Programiranje - (RO) Programarea - (AR) برمجة

IT	Voglio impostare il tempo di chiusura automatica	DE	Ich möchte die Zeit für die automatische Schließung einstellen	PL	Chcę ustawić czas automatycznego zamknięcia	HR	Doresc să setez ora de închidere automată
EN	I want to set the automatic closing time	NL	Ik wil de automatische sluitingstijd instellen	RU	Хочу установить время автоматического закрытия	RO	Țelim namjestiti vrijeme zatvaranja.
FR	Je veux régler le temps de fermeture automatique	PT	Desejo configurar o tempo de fecho automático	CS	Chci nastavit čas automatického zavírání	AR	أريد ضبط وقت الإغلاق التلقائي
ES	Se desea configurar el tiempo de cierre automático.	EL	Θέλω να ρυθμίσω τον χρόνο αυτόματου κλεισίματος	TR	Otomatik kapanma süresini ayarlamak istiyorum		

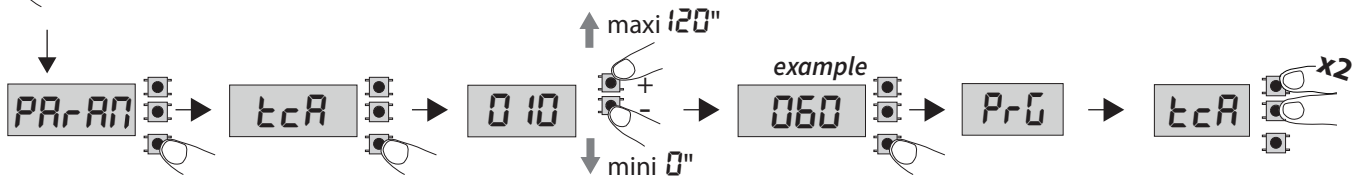
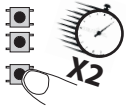

IT	Voglio attivare/disattivare la chiusura automatica	DE	Ich möchte die automatische Schließung aktivieren/deaktivieren	PL	Chcę włączyć/wyłączyć automatyczną blokadę	HR	Țelim aktivirati/deaktivirati automatsko zatvaranje
EN	I want to activate/deactivate the automatic closure	NL	Ik wil de automatische sluiting in-/uitschakelen	RU	Я хочу включить/выключить автоматическое закрытие	RO	Doresc să activez/dezactivez închiderea automată
FR	Je souhaite activer/désactiver la fermeture automatique	PT	Desejo ativar/desativar o fecho automático	CS	Chci aktivovat/deaktivovat automatické zavírání	AR	أريد تفعيل/إلغاء تفعيل الإغلاق التلقائي
ES	Quiero activar/desactivar el cierre automático	EL	Θέλω να ενεργοποιήσω/απενεργοποιήσω το αυτόματο κλείσιμο	TR	Otomatik kapanmayı etkinleştirmek/devre dışı bırakmak istiyorum		

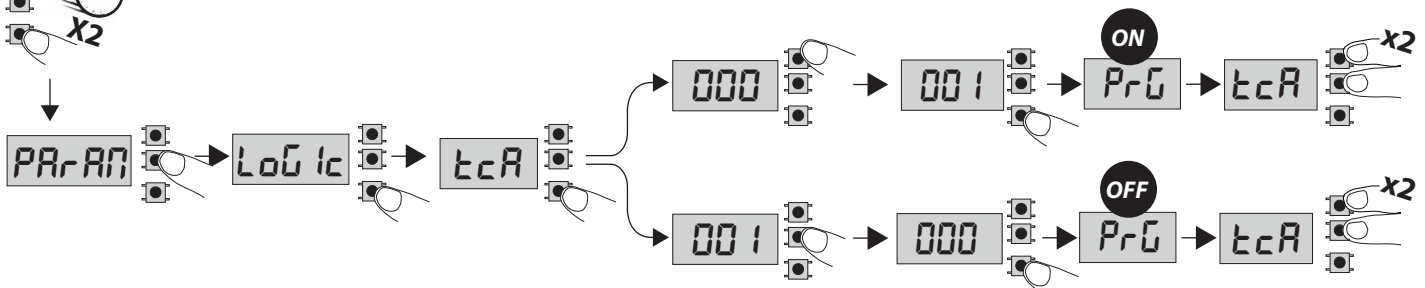
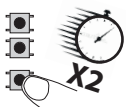

IT	Voglio attivare le fotocellule solo in chiusura
EN	I want to activate the photocells only on closure
FR	Je souhaite activer les cellules photoélectriques uniquement en fermeture
ES	Ich möchte die Lichtschranken nur bei Schließung aktivieren
DE	Quiero activar las fotocélulas solo durante el cierre
NL	Ik wil de fotocellen alleen tijdens het sluiten activeren
PT	Quero ativar as fotocélulas apenas no fecho
EL	Θέλω να ενεργοποιώ τα φωτοκύτταρα μόνο στο κλείσιμο

PL	Chcę aktywować fotokomórki tylko podczas zamykania
RU	Я хочу включить фотоэлементы только при закрытии
CS	Chci aktivovat fotočlánky pouze při zavírání
TR	Fotoselleri salt kapanmada etkinleştirmek istiyorum
HR	Doresc să activez fotocelulele numai la închidere
RO	Želim aktivirati fotočelije samo za zatvaranje
AR	أريد تفعيل الخلايا الضوئية عند الإغلاق فقط

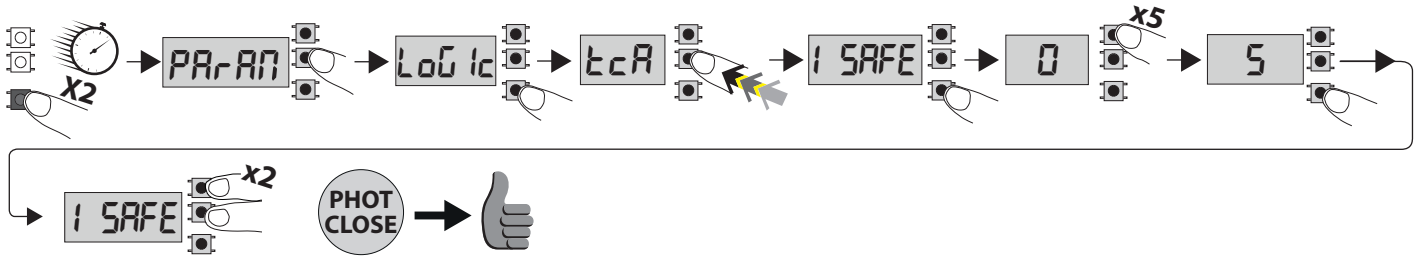

IT	Voglio impostare l'apertura pedonale dal trasmettitore
EN	I want to set pedestrian opening by transmitter
FR	Je souhaite régler l'ouverture piétonne par émetteur
DE	Ich möchte die Fußgängeröffnung über die sender einstellen
ES	Quiero configurar la apertura peatonal desde el transmisor
NL	Ik wil de voetgangerspoort instellen met zenders bediening
PT	Quero configurar a abertura pedonal por transmissore
EL	Θέλω να ρυθμίζω το άνοιγμα για τους πεζούς από το πομπών

PL	Chcę ustawić funkcję otwierania przejścia dla pieszych ze sterowania nadajników
RU	Я хочу настроить пешеходный проход с пульта радиоуправления
CS	Chci nastavit otevření pro chodce pomocí rádiového ovládání
TR	Uzaktan verici yaya açılmasını ayarlamak istiyorum
HR	Doresc să setez deschiderea pietonală prin daljinskog de la distanță
RO	Želim namjestiti otvaranje za pješake s daljinskog transmiđatoar
AR	أريد تعيين فتح مدخل المشاة بواسطة التحكم عن بُعد

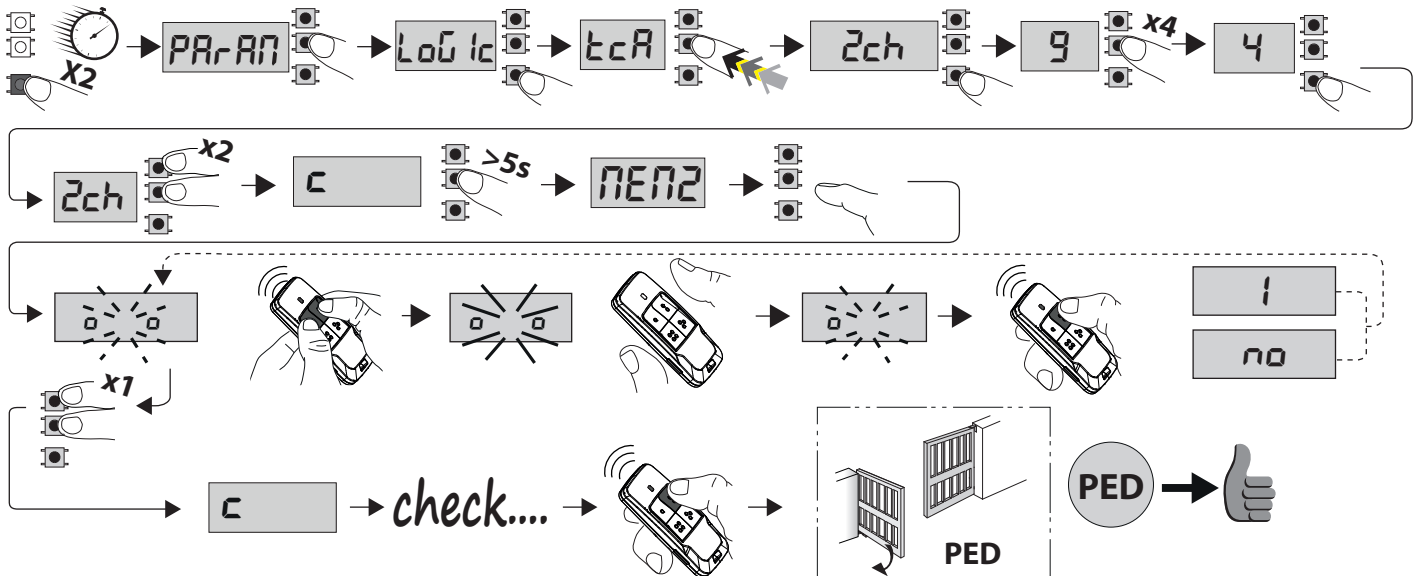

IT	CANCELLAZIONE TRASMETTITORI
EN	TRANSMITTERS CANCELLATION
FR	ANNULATION DES ÉMETTEURS
DE	LÖSCHEN DER SENDER
ES	ELIMINACIÓN TRANSMISORES
NL	WISSEN ZENDERS

PT	CANCELAMENTO DE TRANSMISSORES
EL	ΑΚΥΡΩΣΗ ΠΟΜΠΩΝ
PL	KASOWANIE NADAJNIKÓW
RU	УДАЛЕНИЕ ДАТЧИКОВ
CS	SMAZÁNÍ VYSÍLAČŮ
TR	VERİCİ İPTALI

HR	OTKAZIVANJE ODAŠILJAČA
RO	ȘTERGEREA TRANSMIȚĂTOARELOR
AR	إلغاء أجهزة الإرسال

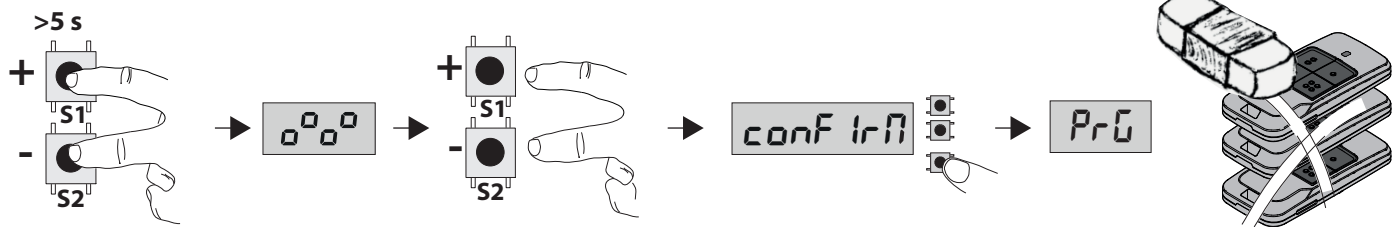

10

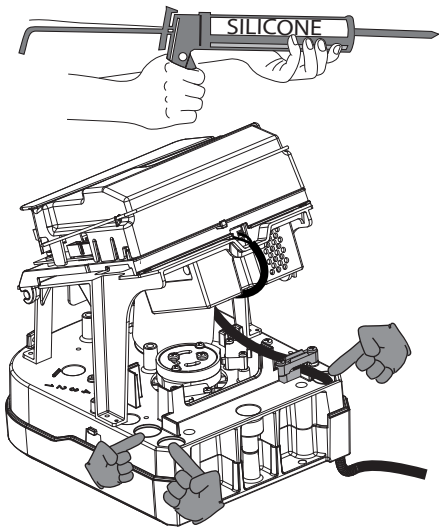

11

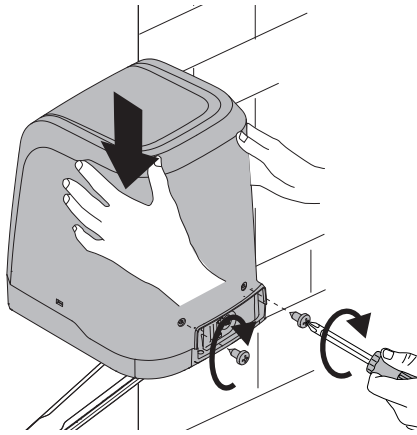

12

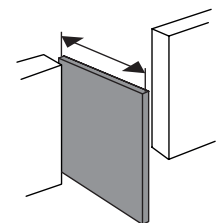
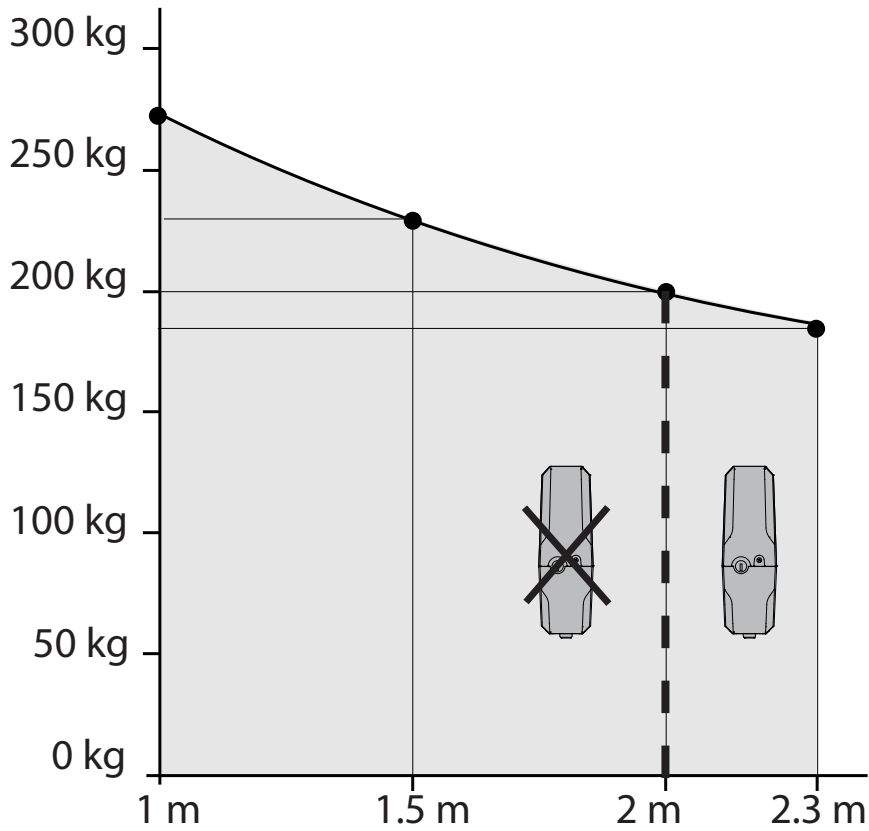
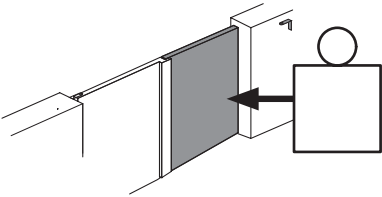

FINAL USER



IT	MANOVRA MANUALE
EN	MANUAL OPENING
FR	OUVERTURE MANUELLE
ES	APERTURA MANUAL

DE	MANUELLE ÖFFNUNG
NL	HANDMATIGE OPENING
PT	ABERTURA MANUAL
EL	ΧΕΙΡΟΚΙΝΗΤΟ ΑΝΟΙΓΜΑ

PL	OTWIERANIE RĘCZNE
RU	РУЧНОЕ ОТКРЫТИЕ
CS	MANUÁLNÍ OTEVÍRÁNÍ
TR	MANUEL AÇMA

HR	RUČNO OTVARANJE
RO	DESCHIDERE MANUALĂ
فتح يدوي	AR

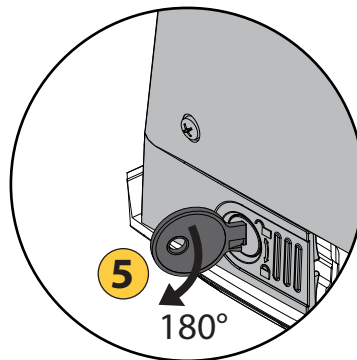
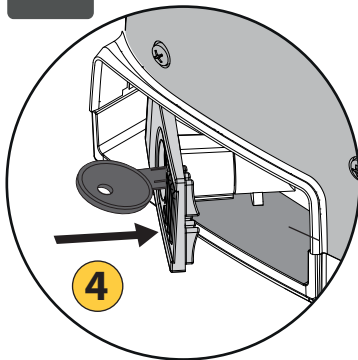
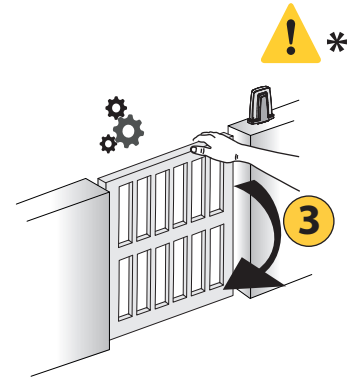
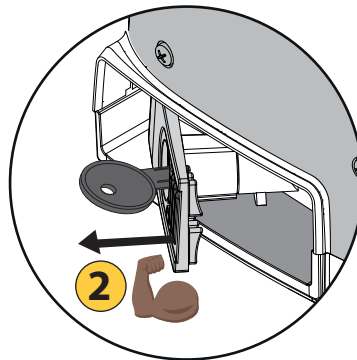
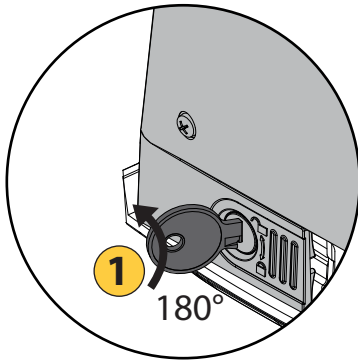

IT	Attenzione! Non spingere VIOLENTEMENTE l'anta del cancello.
EN	Warning! Do not push the gate WITH EXCESSIVE FORCE
FR	Attention! Ne poussez pas VIOLEMMENT le vantail du portail.
ES	¡Atención! No empuje CON VIOLENCIA la hoja de la puerta.
DE	Achtung! Schieben Sie den Torflügel nicht MIT GEWALT an.

NL	Let op! Duw niet MET GEWELD tegen de deur van het hek.
PT	Atenção! Não empurrar COM FORÇA a folha do portão.
EL	Προσοχή! Μην σπρώχνετε ΜΕ ΜΕΓΑΛΗ ΔΥΝΑΜΗ το φύλλο της πύλης.
PL	Uwaga! Nie należy GWAŁTOWNIE popychać skrzydła bramy.
RU	Внимание! Не толкайте СЛИШКОМ СИЛЬНО створку ворот.

CS	Pozor! Na křídlo brány netlačte PŘÍLIŠNOU SILOU.
TR	Dikkat! Kapının kanadını ŞİDDETLİ bir şekilde itmeyin.
HR	Nemojte gurati vrata uz primjenu PREKOMJERNE SILE!
RO	Nu împingeți bariera CU FORȚĂ EXCESIVĂ.
AR	لا تدفع البوابة بقوة زائدة



AZIENDA CON
SISTEMA DI GESTIONE
CERTIFICATO DA DNV GL
= ISO 9001 =
= ISO 14001 =

