

Axovia 220B

EN Installation instructions

Exploded diagram of the product

1	Motor	x 2	17	Earth bolt	x 1
2	Motor arm	x 2	18	Earth washer	x 1
3	Gate leaf arm	x 2	19	12x27 clamp washer	x 8
4	Gate leaf bracket	x 2	20	Shaft bolt / motor arm HM 10x40	x 2
5	Electronic unit	x 1	21	End stop cover bolt	x 4
6	Motor cover	x 2	22a	Upper stop cover	x 2
7	Motor cover bolt	x 4	22b	Lower stop cover	x 2
8	Information card	x 1	23	End stop bolt	x 6
9	Enclosure cover	x 2	24	End stop (upper part + lower part)	x 2
10	O-ring	x 2	25	Motor arm / gate leaf arm short shaft	x 2
11	Cover bolt	x 2	26	Gate leaf arm / bracket long shaft	x 2
12	Electronics earth wire	x 1	27	Gate leaf arm ring	x 4
13	Electronic unit bolt	x 1	28	Gate leaf arm damper	x 2
14	Grommet	x 2	29	Aerial	x 1
15	Cable clip	x 4	30	Cover key	x 2
16	Cable clamp bolt	x 8			

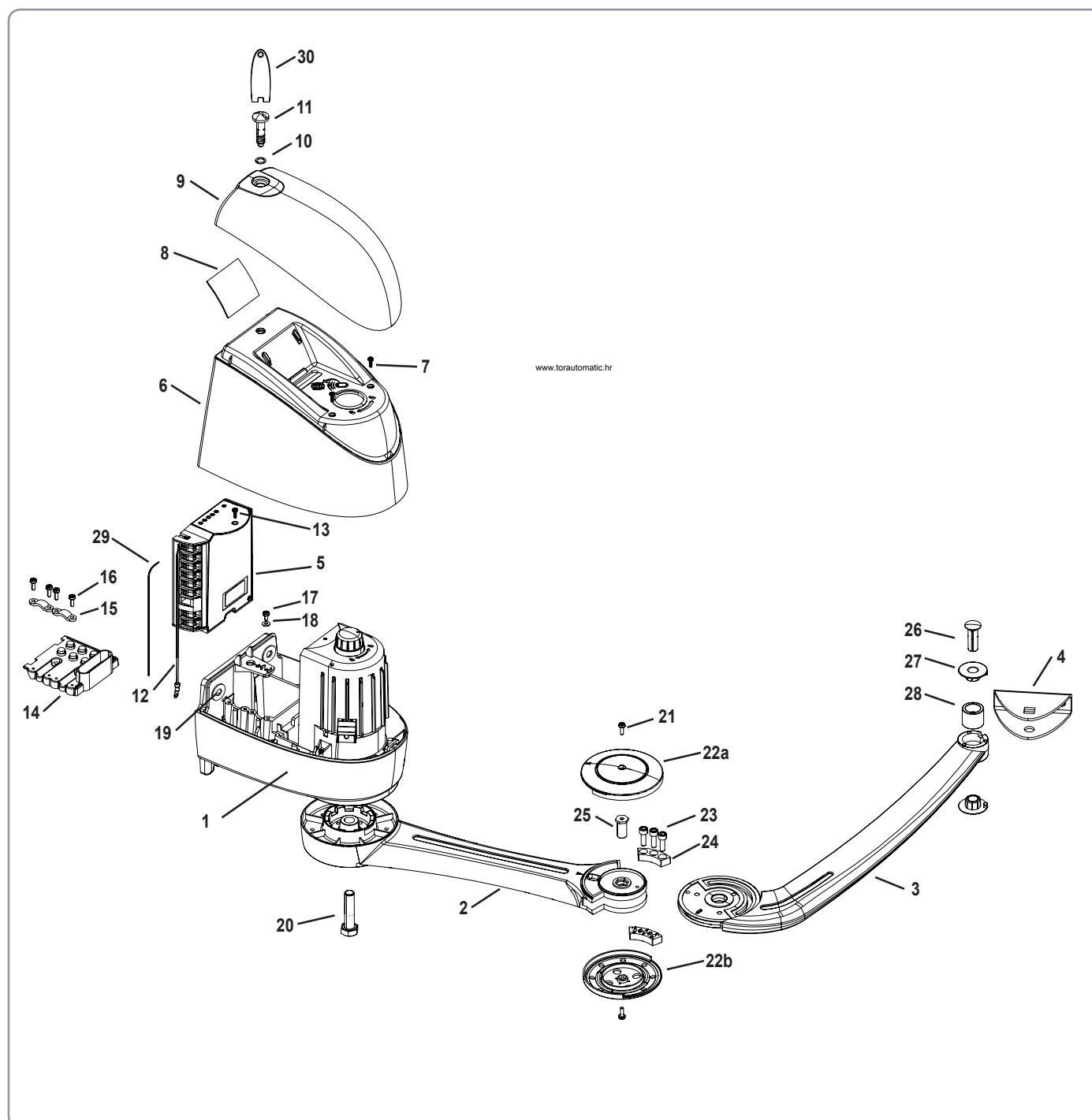

CONTENTS

GENERAL INFORMATION	2
SAFETY	2
Caution	2
Safety instructions relating to installation	2
PRODUCT DESCRIPTION	3
Size of motor (in mm)	3
Technical data	3
Description of operation of the indicators	4
PRE-INSTALLATION CHECKS	4
Gate	4
Pillars	4
Reinforcements	4
Area of application	4
PREPARATION AND DRILLING OF PILLARS	5
MOUNTING AND FIXING OF THE MOTORS	6
INSTALLING THE INTEGRATED OPENING END STOP	8
ELECTRICAL CONNECTIONS	9
Cable guide fitting	9
Connecting the motors	9
Aerial wiring	9
Mains cable connection	9
Locking the arms	10
Switching the installation on	10
QUICK COMMISSIONING	10
Storing the remote controls	10
Gate travel self-learning	11
OPERATION	11
ADVANCED PARAMETER SETTING	12
Activating automatic closing mode	12
Switching to sequential mode after activating automatic closing mode	12
Memorising a 3 button remote control	12
CONNECTING ADDITIONAL DEVICES	13
General wiring diagram	13
Photoelectric cells	13
Orange light	14
Key lock	14
Exterior aerial	14
Entry phone	15
Backup battery	15
Area lighting (500 W max with 230 V)	15
Digicode	15
SOLAR	16
Connection to the solar power supply	16
Advice for use	16
DIAGNOSTIC AND REPAIRS	17
Ambient light detector	17
Clear the settings	18
Clear the memorised settings and remote controls	18

GENERAL INFORMATION

Installing this product in accordance with these instructions ensures that the set-up complies with standards EN 12453 and EN 13241-1.

The instructions referred to in the product's installation guide and instructions for use are designed to prevent damage to property and personal injury along with compliance with the above standards.

Somfy declares that this product complies with the essential requirements and other relevant provisions of Directive 1999/5/EC. A Declaration of conformity is available at www.somfy.com/ce (Axovia 220B).

Product can be used in the European Union, Switzerland and Norway.

SAFETY

Caution

Always read this installation guide and the attached safety instructions before installing this Somfy product.

This guide describes how to install, commission and operate this product. Follow all the instructions as incorrect installation can lead to serious injury.

Any use outside the sphere of application specified by Somfy is forbidden. This invalidates the warranty and discharges Somfy of all liability, as does any failure to comply with the instructions given herein.

This Somfy product must be installed by a professional motorisation and home automation installer, for whom this guide is intended.

Moreover, the installer must comply with current standards and legislation in the country in which the product is being installed, and inform his customers of the conditions for use and maintenance for the product. It is the installer's responsibility to ensure that the automatic installation and its operation are compliant with the standards in force.

This device is not designed to be used by persons (including children) whose physical, sensory or mental capacity is impaired, or persons with little experience or knowledge, unless they are under supervision or have received instructions on using the device by a person responsible for their safety.

Safety instructions relating to installation



Somfy refuses to accept any responsibility as regards the safety and correct operation of the motorisation if non-Somfy components are used.

No modifications may be made to the components of the motorisation system unless expressly authorised by Somfy. Inform the user about the operation of the control systems and the manual opening procedure in the event of an emergency. Installations which do not comply with the specifications in this manual or improper use of the product may cause injury or damage the equipment.

www.torautomatic.hr

Installation area

Before installation, ensure that the installation location complies with the provisions of the current standards. In particular, the position in which the motorisation mechanism will be fitted must allow for safe and easy manual release of the gate.

Ensure that there are no danger zones (risk of crushing, cutting, trapping) between the gate and the surrounding fixed elements caused by the opening movement of the gate.

Do not install the product in an explosive environment.

Maintain a clear area of 500 mm behind the gate when it is completely open.

Installation

Before installing the motor, ensure that the driven part is in good mechanical condition, that it is correctly balanced and that it opens and closes correctly.

On a barred gate, if the bars are more than 40 mm apart, install an appropriate safety device to prevent cutting.

If the gate is barred, we would suggest you protect the access to the arm from the outside of the property.

Place the fixed control devices and remote controls out of the reach of children.

Any switch without a locking device must be installed in direct view of the gate and away from any mobile parts. The minimum height at which it must be installed is 1.5 m. It must not be accessible to the public.

During installation of the motorisation

Watch the gate while it is moving.

Remove any jewellery (bracelets, chains, etc.).

For drilling and welding operations, wear special glasses and sufficient protection.

Use the appropriate tools.

Do not connect to the mains or to a backup battery before installation is complete.

Be careful when handling the motorisation system to prevent any risk of injury.

Manual unlocking may result in uncontrolled movement of the gate leaf.

Power supply

In order to operate, the motor must be supplied with 230 V 50 Hz. The electric line should be:

- be exclusively reserved for the motorisation,
- have a minimum cross-section of 1.5 mm²,
- be fitted with an approved all-pole switch with contact openings of at least 3.5 mm, fitted with a protection device (fuse or circuit breaker with a 16 A rating) and a differential device (30 mA),
- be installed in accordance with the current electrical safety standards,

- be fitted with a lightning conductor (in compliance with standard NF C 61740, maximum residual voltage 2 kV),

Check whether the earthing system is installed correctly: connect all the metal parts of the assembly and all the components of the installation equipped with earth terminals.

After installation, ensure that the mechanism is correctly adjusted and that the protection system and any manual release mechanism operate correctly.

Safety devices

The selected safety accessories for the installation must comply with the current standards and regulations in force in the country in which the product is being installed. The use of any safety components not approved by Somfy remains the sole responsibility of the installer.

Install all the safety devices (photoelectric cells, safety edges, etc.) required to protect the zone from the danger of crushing, entanglement and cutting according to the applicable directives and technical standards.

In accordance with standard EN 12453 governing the safe use of motorised gates and doors, the use of the TAHOMA control box to automatically control a garage door or gate not visible to the user requires the installation of a photoelectric cell type safety device with autotest on the automatic control system.

Maintenance

Regularly check the condition of the gate. Gates in poor condition must be repaired, reinforced or even replaced. Check that the various motorisation component's screws and fittings are correctly tightened.

Before carrying out work on the installation, switch off the power supply.

Use only original parts for any maintenance or repair work.

PRODUCT DESCRIPTION

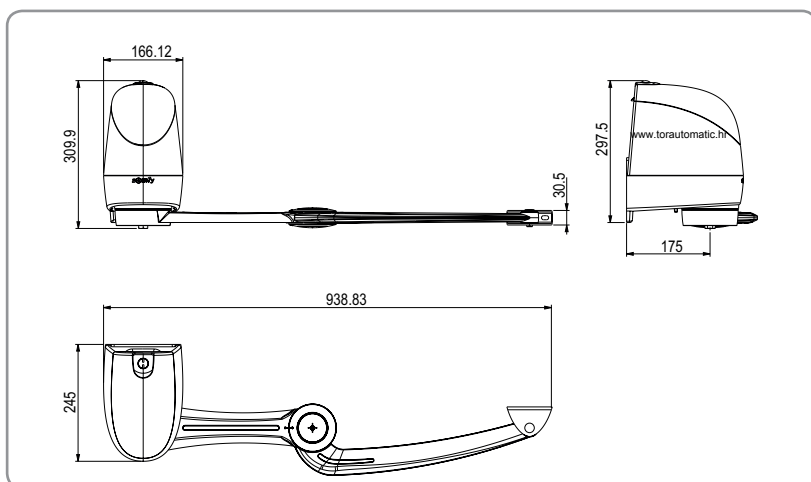

Size of motor (in mm)



Technical data

Power supply	230 V - 50/60 Hz
Standby power consumption (excluding accessories)	2.6 W
Standby solar power consumption	1 W
Max. power consumption	600 W
Average frequency of movements per day	20 cycles/day
Max. thrust force at 1.25 m	< 15 kg EN 12453
Operating temperature	-20°C to +60°C
Thermal protection	Yes
Index protection rating	IP 44
Integrated radio receiver	Yes
Number of storable remote controls	16
Motor feed outputs	24 V DC
Power per motor	120 W
Output for orange light	Flashing, 24 V, 15 W
Area lighting output	500 W max.
Accessories supply output	24 V CC/1 A (including orange light)
Backup battery input	Yes
Photoelectric cell input	Yes (1 or 2 sets)
Dry contact input	Yes

Description of operation of the indicators

RADIO indicator light	Radio frame received
Off:	No radio reception
Lit:	Radio command received
 indicator light	Pedestrian opening
On:	Lights up when pedestrian opening is activated/ deactivated using one of the remote control buttons
 indicator light	Automatic closing
Off:	Automatic closing mode not activated
Continuously lit:	Automatic closing mode activated
Flashing:	Awaiting activation/deactivation of automatic closing mode
RESET indicator light	Clearing settings/transmitters
Continuously lit:	Awaiting clearing order for settings and/or transmitters
Flashing:	Settings and/or transmitters cleared
 indicator light	Operating diagnostics
Off:	Motor not supplied or on standby
Continuously lit:	Motor operational
Flashing:	See diagnostic table on page 17

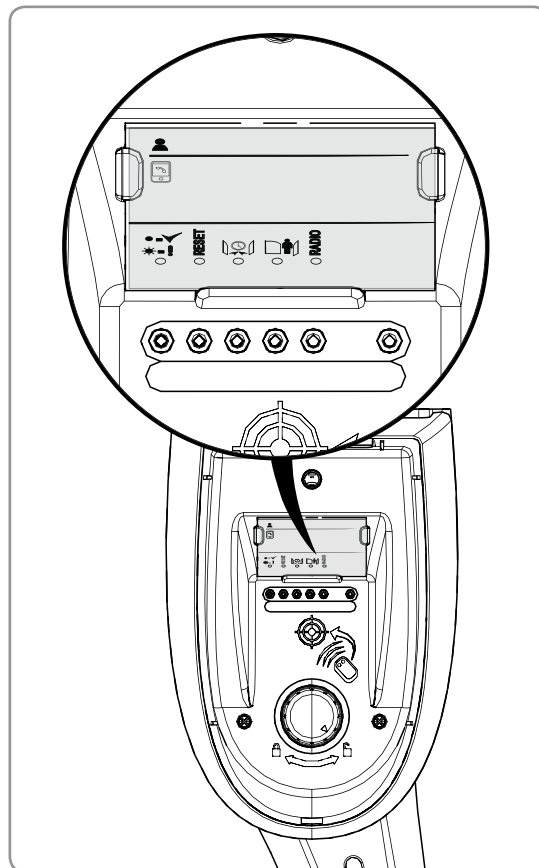

PRE-INSTALLATION CHECKS

www.torautomatic.hr

Gate

The gate must be in good condition: ensure that its structure is suitable for automatic control and that it conforms to the relevant standards. The gate must remain horizontal throughout its travel, and must open and close manually with ease.

Pillars

The pillars are untrue so require the use of an intermediate plate.

Furthermore, when one of the motor clamp mounting holes is not resting on anything or is close to the angle of the pillar or wall, it is essential to use the intermediate plate (ref. 2400485).

Reinforcements

If the gate has no reinforcements, prepare some metal reinforcement plates (e.g.: 15x15 cm and 4 cm thick) to secure the brackets to the gate leaves.

Area of application

This product is intended for the motorisation of a hinged gate for an individual home.

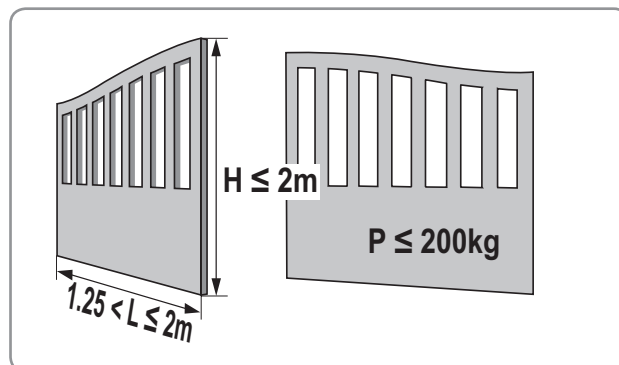

PREPARATION AND DRILLING OF PILLARS

For the indicated values, the gate leaves and their hinge pins are taken to be on the same axis.

If the hinge pins are offset, the maximum opening angle values will be reduced.

[1]. Measure dimension A.

[2]. Select dimension B in the table according to the required opening angle.

A (mm)	α max. (°)	B (mm)
0	120	205
	110	160
	105	150
50	100	150
100	95	150
150	90	150
200	90	150
250	90	150

[3]. Trace axis AM on the pillar copying dimension B on the pillar.

[4]. Check that dimension D is greater than or equal to 435 mm.

There must be no obstacles to impede the movement of the arm in this area.

[5]. Check that dimension L is between 1250 mm and 2000 mm.

www.torautomatic.hr

[6]. Trace horizontal line AH in the middle of the reinforcement, perpendicular to the rotational axis of the gate.

If the gate has no reinforcements, place the motors approximately 1/3 of the way up the gate leaves from the bottom.

Extend this line on the pillar until it intersects with AM.

[7]. Place the template where the 2 lines intersect and drill.

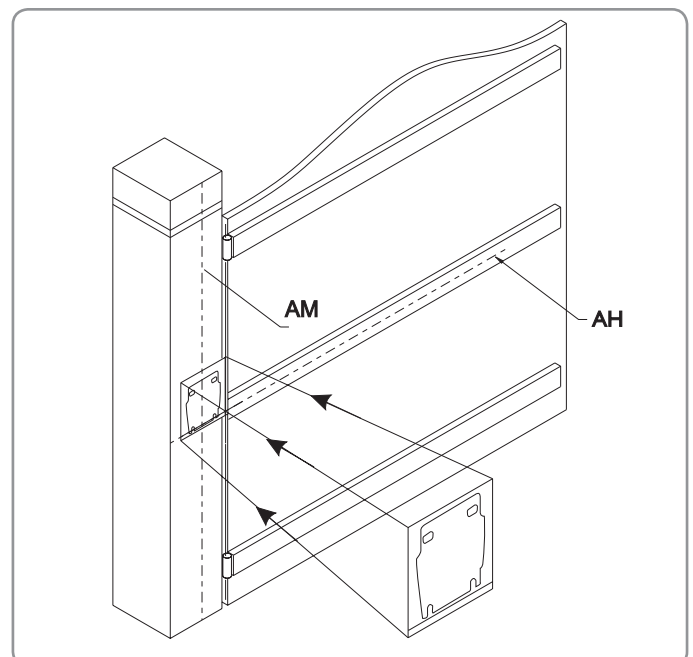
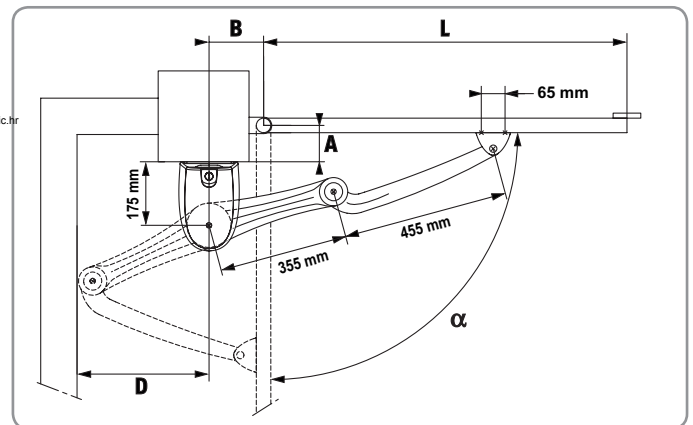
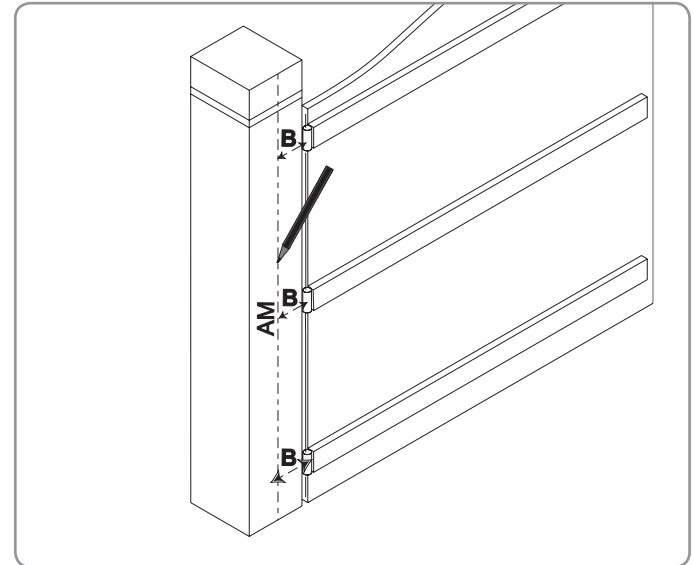
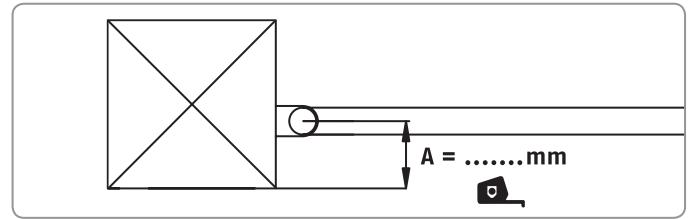

MOUNTING AND FIXING OF THE MOTORS

[1]. Open the upper cover using the specific key supplied.

[2]. Unscrew the 2 bolts of the lower cover and remove.

Info card: for improved legibility, use a permanent marker.

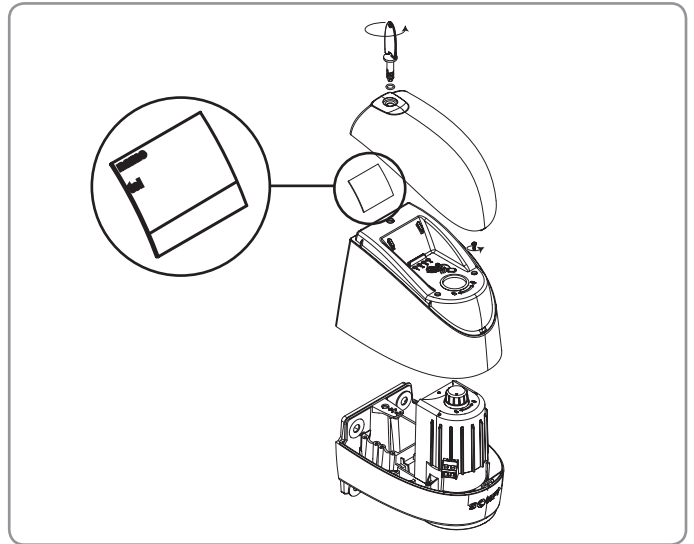

[3]. Attach the motor, checking the level.

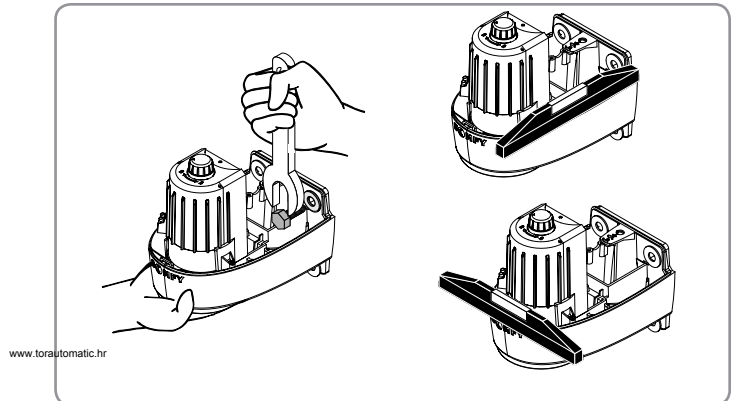

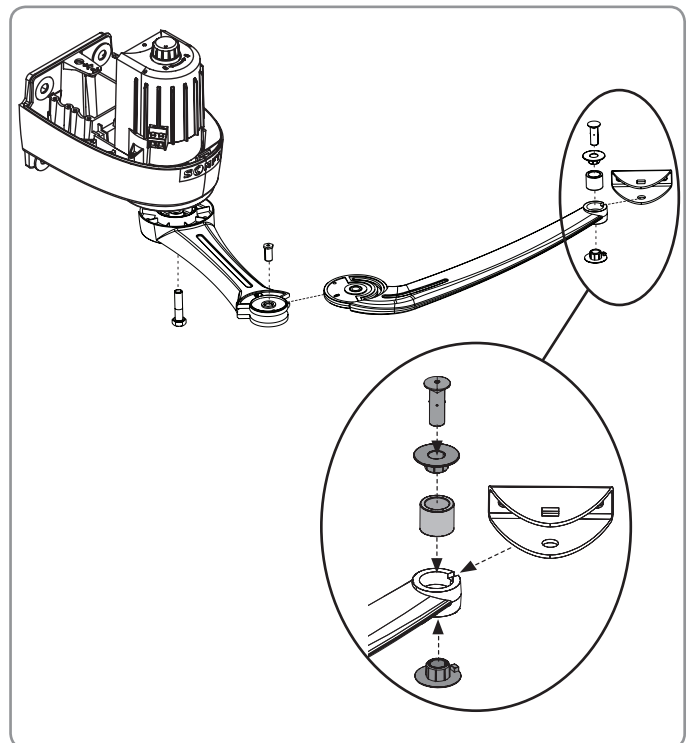

[4]. Assemble:

- the motor arm to the motor with an HM 10x40 bolt (20)
- the gate leaf arm to the motor arm with the short shaft (25)
Note: the gate arm can be fitted both ways.
- the gate leaf bracket to the gate leaf arm with a damper (28), 2 rings (27) and a long shaft (26).



[5]. Unlock the motor arms using the button located on the top of the motor.

: arms locked

: arms unlocked - manual operation



In unlocked position, move the arms slowly to avoid damaging the motors.

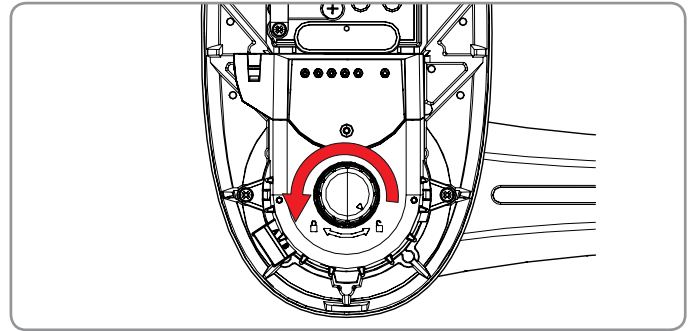

[6]. To ensure correct closing of the gate, push the motor arm and the gate firmly:

- the gate arm must be completely unfolded,
- the mounting tab must be flat against the reinforcement,
- the gate arm marking must be lined up with the motor arm arrow.



Ensure the markers on the motor arm and the gate arm are lined up to ensure the gate is properly closed and can withstand strong winds or external forces.

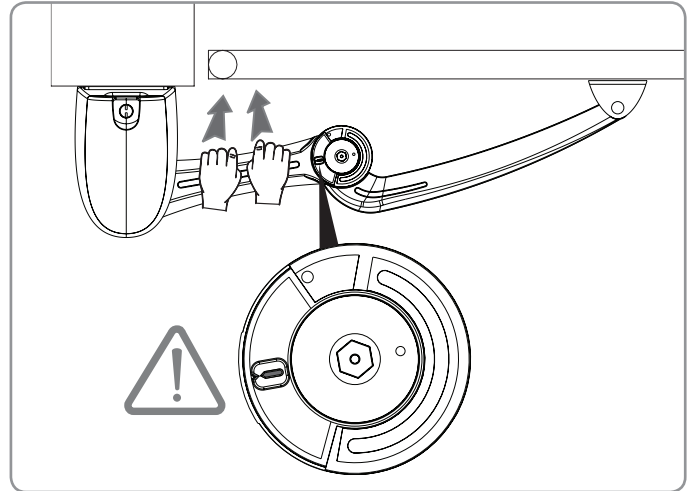

[7]. Mark the centre-to-centre distances for mounting the bracket to the gate.

www.torautomatic.hr

[8]. Remove the gate arm.

[9]. Drill the gate leaf reinforcement.

[10]. Attach the bracket.

[11]. Put the gate arm back into position.

[12]. Check that the position of the bracket on the gate is correct by manually opening the gate.
If necessary, correct the position.

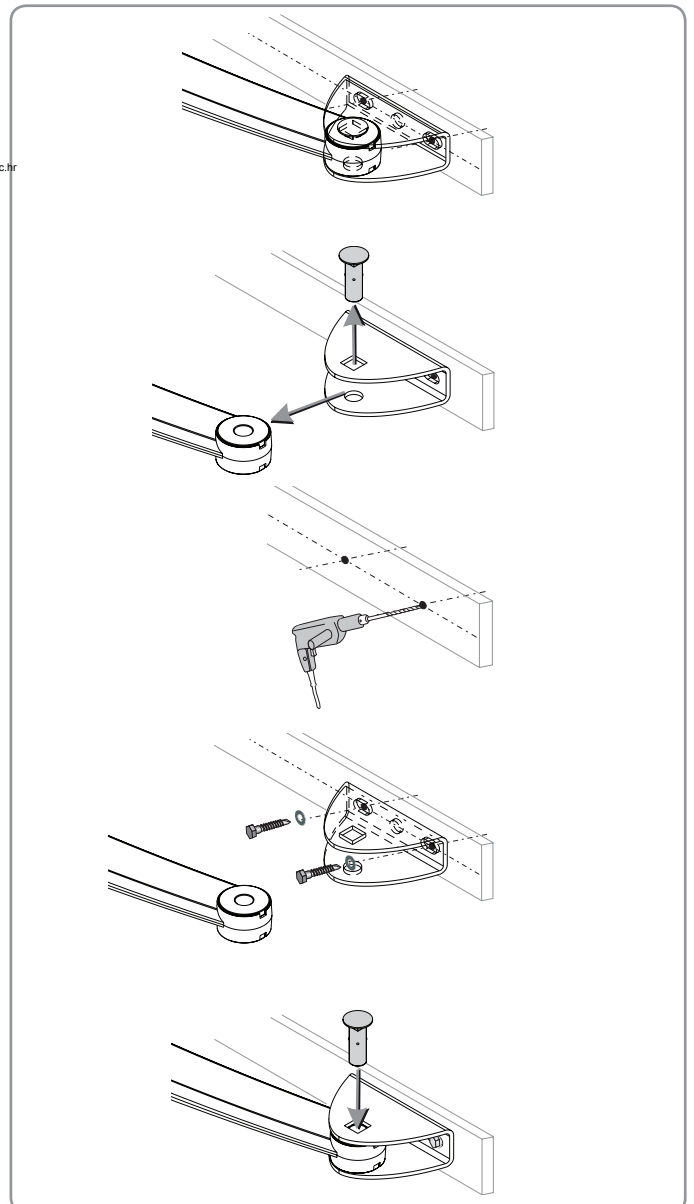

INSTALLING THE INTEGRATED OPENING END STOP

[1]. Manually open the gate to the opened position α required.

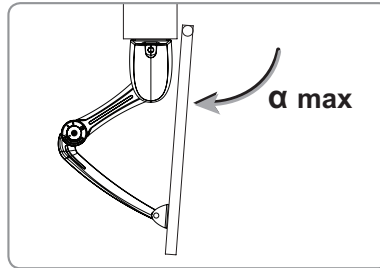

[2]. Install the end stop on the bracket side, flush against the shoulder of the motor arm.
Do not tighten the stop.

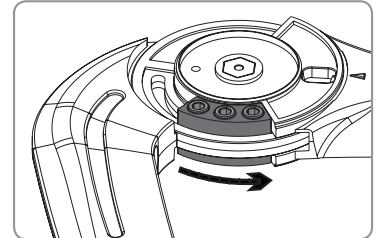
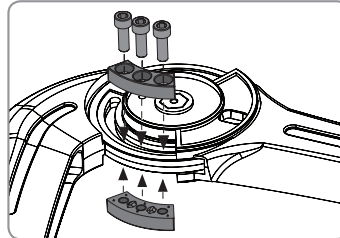

[3]. Close the gate slightly.

[4]. Move the end stop approximately 2 mm towards the motor arm shoulder.

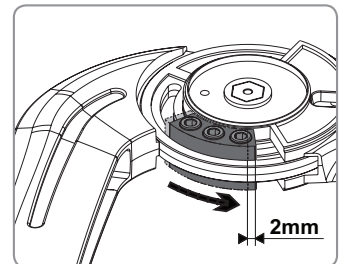
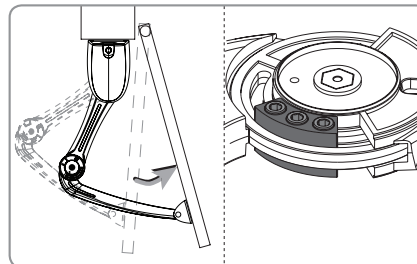

[5]. Tighten the end stop with a long Allen key for greater torque when tightening the end stop bolts (16 Nm).

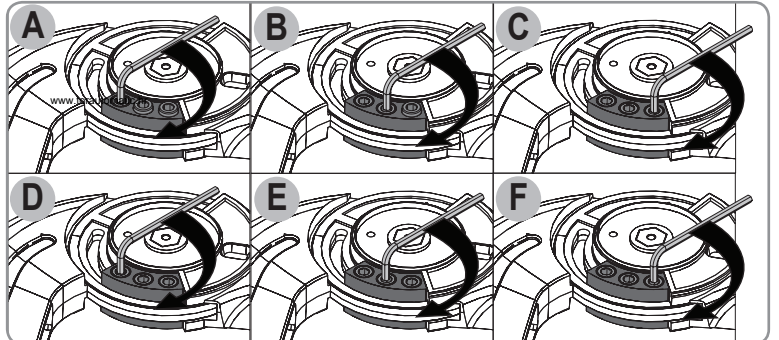

[6]. Install the end stop covers: screw the lower cover (with holes) (22b), holding the shaft while performing this operation, then screw in the upper cover (22a).

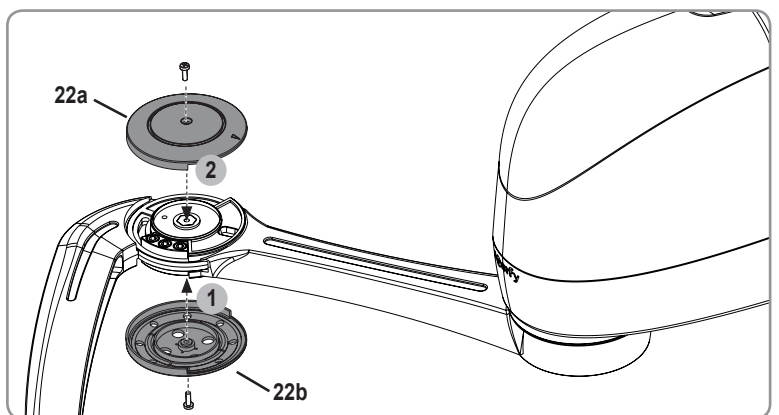

[7]. Permanently fix the gate leaf bracket using the central mounting hole.

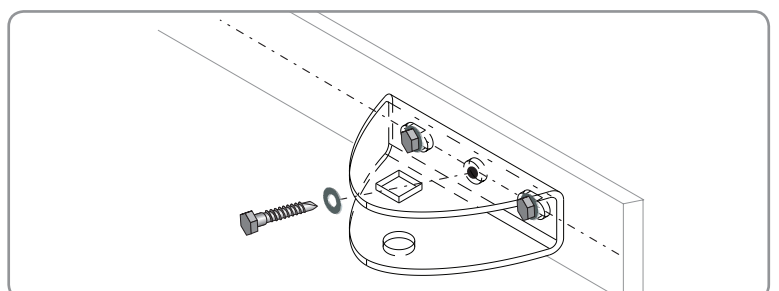

ELECTRICAL CONNECTIONS

Cable guide fitting

Fit the cable guides on the two motors.

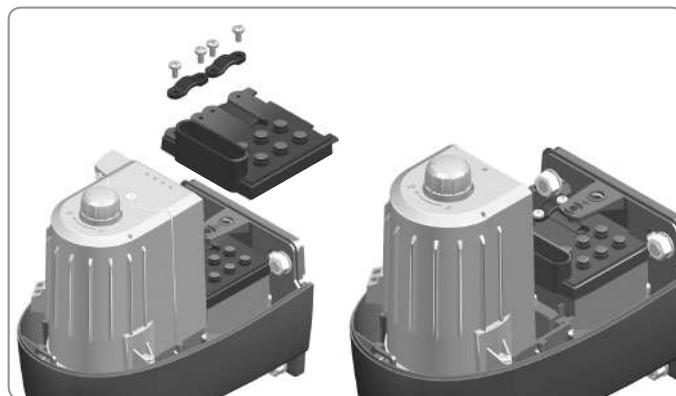

Connecting the motors

Motor M1 actuates the gate leaf that opens first and closes last, and opens for pedestrian access.

[1]. With the gate closed, identify the location of motor M1 by identifying the gate leaf that will open first.

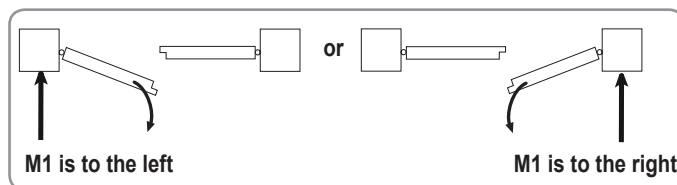

[2]. Connect the motors as indicated in the table below.

If M1 is to the left and M2 to the right			If M1 is to the right and M2 to the left		
connect the wire of ...		to terminal ...	connect the wire of ...		to terminal ...
M1	blue	9	M1	brown	9
	brown	10		blue	10
M2	brown	11	M2	blue	11
	blue	12		brown	12

www.torautomatic.hr

To connect the motor without electronics to the electronic unit, use a terminal block, a connecting strip or a distribution box (not supplied) to be placed in the motor before refitting the cover.

Aerial wiring

For optimum performance, it is essential the aerial is correctly positioned.



Do not cut the cut the aerial wire.

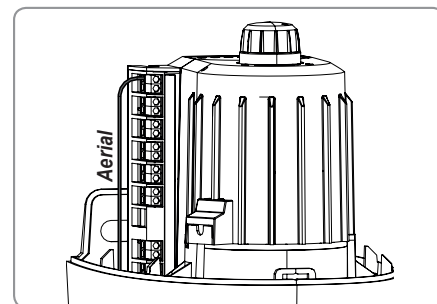

Mains cable connection

Connect the live and neutral as per the following table.

		Terminal
Blue wire	Neutral	15
Red/brown/black wire	Live	16
Green and yellow wire	Earth	



Ensure the wire colours are observed.

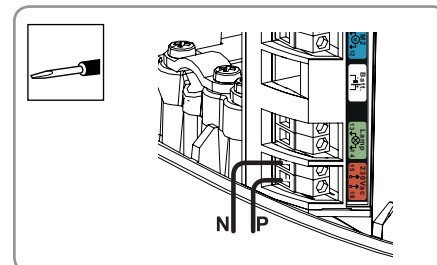

Connect the power supply earth wire and the electronics earth wire (12) to the motor clamp.

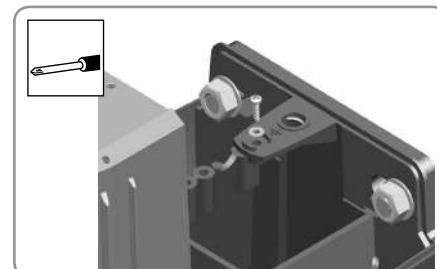

Locking the arms

- [1]. Close the two gate leaves and lock the arms by pressing them.
- [2]. Turn the motor locking handles to the locked position .

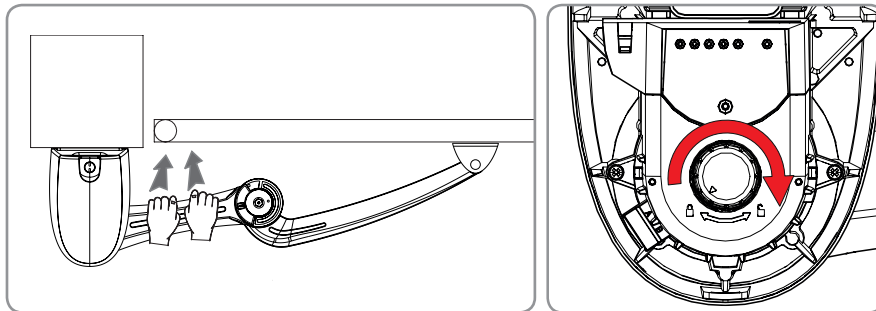

Switching the installation on

Switch the installation on.

The  indicator light on the electronic unit will flash (2 pulses) to indicate that the motors are on and awaiting setting.

If the  indicator light stays off, refer to the repair help on page 17.

QUICK COMMISSIONING

Memorising the remote controls

The remote controls can be memorised for full opening and pedestrian opening of the gate:

- pressing the programmed button for full opening causes the 2 gate leaves to open fully,
- pressing the programmed button for pedestrian opening causes one gate leaf to open for pedestrian access.

 **It is not possible to memorise more than 16 transmitters. Delete all the remote controls and resume programming.**

Selecting the remote control buttons

Any of the remote control buttons can be programmed to control full opening of the 2 gate leaves.

www.torautomatic.hr

If activated, the following button can be used to open the a gate leaf in pedestrian mode.

 **Button 1 can only be programmed for full opening. This button cannot be programmed for pedestrian opening.**

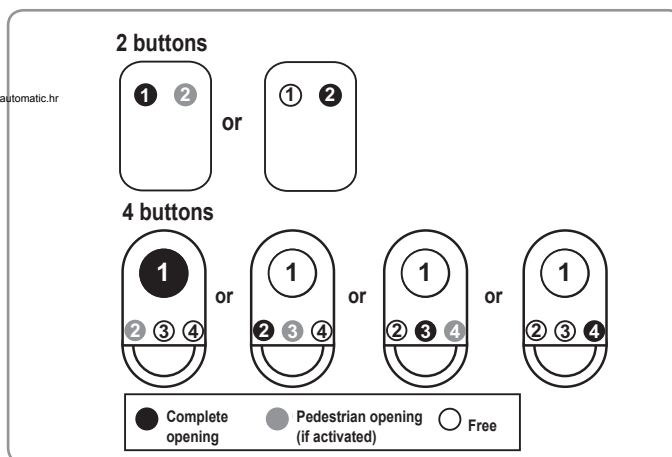

To memorise a remote control for full opening

- [1]. Position the remote control on the target engraved on the cover.
- [2]. Briefly press the button on the remote control that will open the gate fully.
The RADIO indicator light comes on then goes out when the button is released. The button has been memorised.

To activate pedestrian opening on one button

- [1]. Position the remote control on the target engraved on the cover.
- [2]. Briefly press the button on the remote control to be activated to open the gate in pedestrian mode.
The RADIO and  indicator lights come on then go out when the button is released. Pedestrian opening is activated on this button.

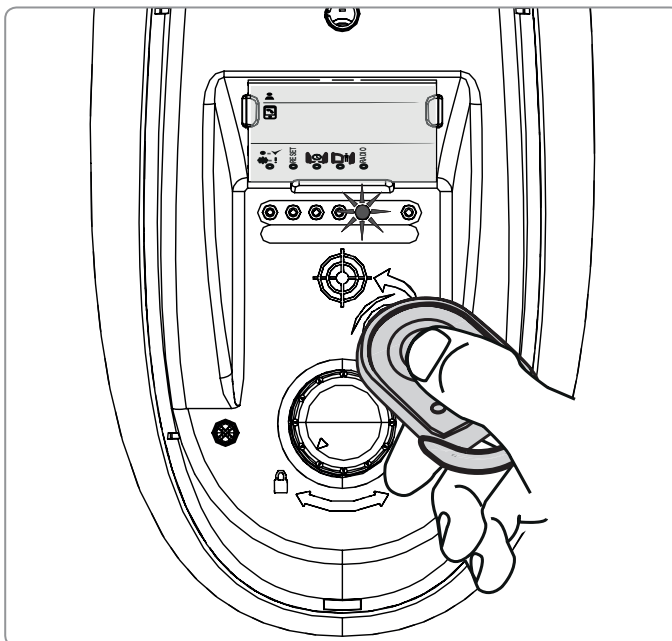

Gate travel self-learning



Self-learning of the gate's travel is essential when commissioning the motor.
The gate must be closed before auto programming is started and at least one remote control must have been programmed.

Auto-programming consists of making the gate perform two gate leaf opening and closing cycles.

[1]. Move the remote control away from the receiver.

[2]. Press the programmed button to open the gate fully. The gate opens at slow speed.



If the gate does not open, or moves in the direction of closing, check the motor wiring (see page 9).

[3]. Once both leaves of the gate are fully open, press the programmed button on the remote control again. The gate closes, one gate leaf at a time.

[4]. Initiate a second opening and closing cycle. This time, the two gate leaves will close at the same time. At the end of the second closing, the  indicator light will go out, which indicates the end of the self-learning phase.

If the  indicator light flashes after 2 complete opening/closing cycles, consult the repair help on page 17.

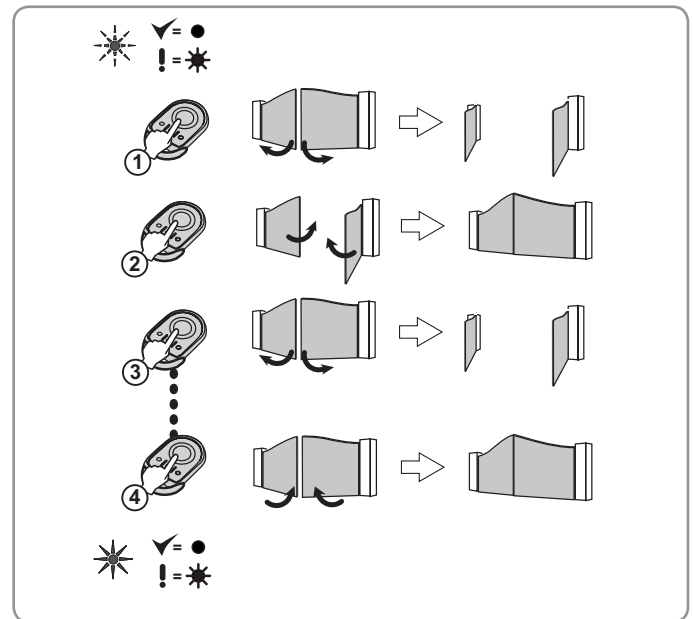

The movement of the gate leaves during auto programming are always carried out at a reduced speed.

The two opening/closing cycles must be complete for auto programming to take place. If the movement of the gate is interrupted during auto programming, the process is delayed and will resume next time the gate is fully opened.

THE MOTOR IS READY TO OPERATE. It will operate in sequential mode by default.

www.torautomatic.hr

OPERATION

The motor can operate in sequential mode or automatic closing mode.

Sequential mode: successive presses of the same remote control button will lead to the following movements: Open, Stop, Close, Stop, Open etc.

Automatic closing mode: pressing the programmed button of the remote control will cause the gate to open. The gate will close automatically after 30 seconds. If photoelectric cells are installed, any movement in front of the cells will cause the gate to close automatically after 5 seconds.

The gate can be held in the opened position by giving a stop command during the time delay. To close the gate, press the remote control button again.

3-button remote control - Using the central button

With the gate closed, pressing the central button on the remote control causes the gate to open in pedestrian mode (motorised opening of the gate by motor M1).

If the gate is moving, pressing the central button of the remote control will cause the gate to stop.

For more information, refer to the user section.

ADVANCED PARAMETER SETTING

Activating automatic closing mode



By default, the motor will be in sequential mode.

When using your gate in automatic mode, standard EN 12 453 requires a set of photoelectric cells to be installed (see wiring on page 13). It is only possible to switch to the automatic operating mode if a set of photoelectric cells is installed. Somfy recommends installing an orange light (see wiring on page 14) and area lighting (see wiring on page 15).

This operating mode is not compatible with remote control using a TaHoma unit.

N.B.: button 1 and button 2 position

2 buttons

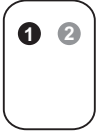

4 buttons



- [1]. Place a programmed remote control on the target engraved on the cover.
- [2]. Press button 1 on the remote control until the indicator light flashes.
- [3]. Press button 2 on the remote control until the indicator light goes out then comes on continuously.
The indicator light flashes.
- [4]. Press button 1 on the remote control twice.
The indicator light stays on to show that automatic closing mode is active.

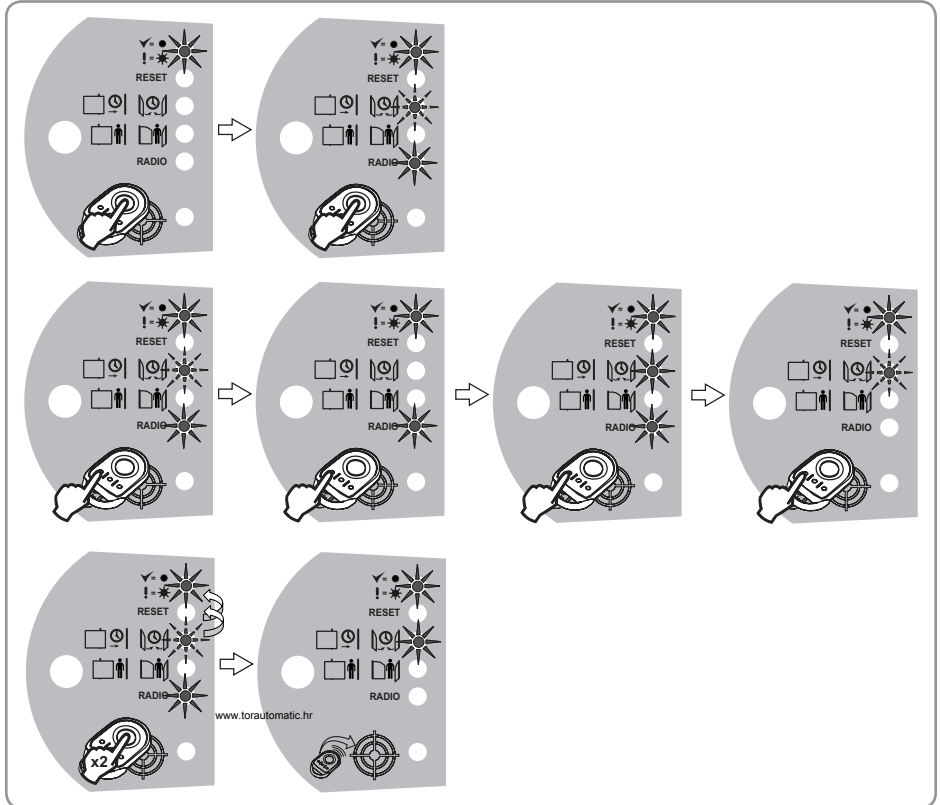

Switching to sequential

mode after activating automatic closing mode

To return to sequential mode, repeat steps 1 and 2 above then briefly press button 2 on the remote control. The indicator light goes out then flashes. Press button 1 on the remote control twice.

Memorising a 3 button remote control



It is not possible to memorise more than 16 transmitters. Delete all the remote controls and resume programming.

- [1]. Position the remote control on the target engraved on the cover.
- [2]. Briefly press the Up or Down button on the remote control.
The RADIO indicator light comes on then goes out when the button is released. The remote control has been memorised.

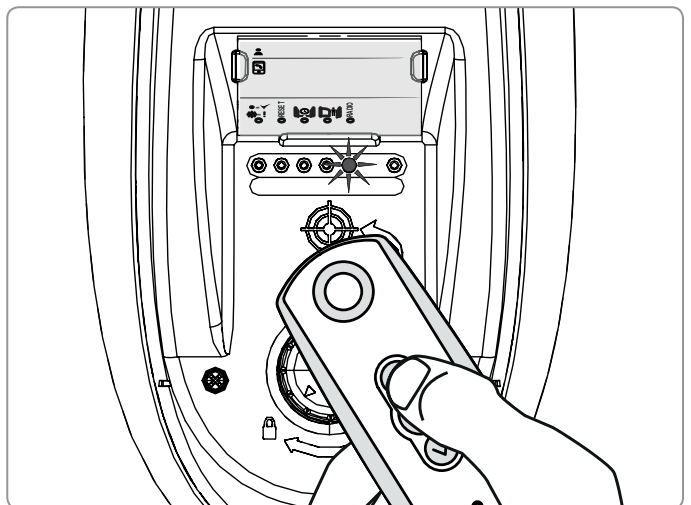

CONNECTING ADDITIONAL DEVICES

General wiring diagram

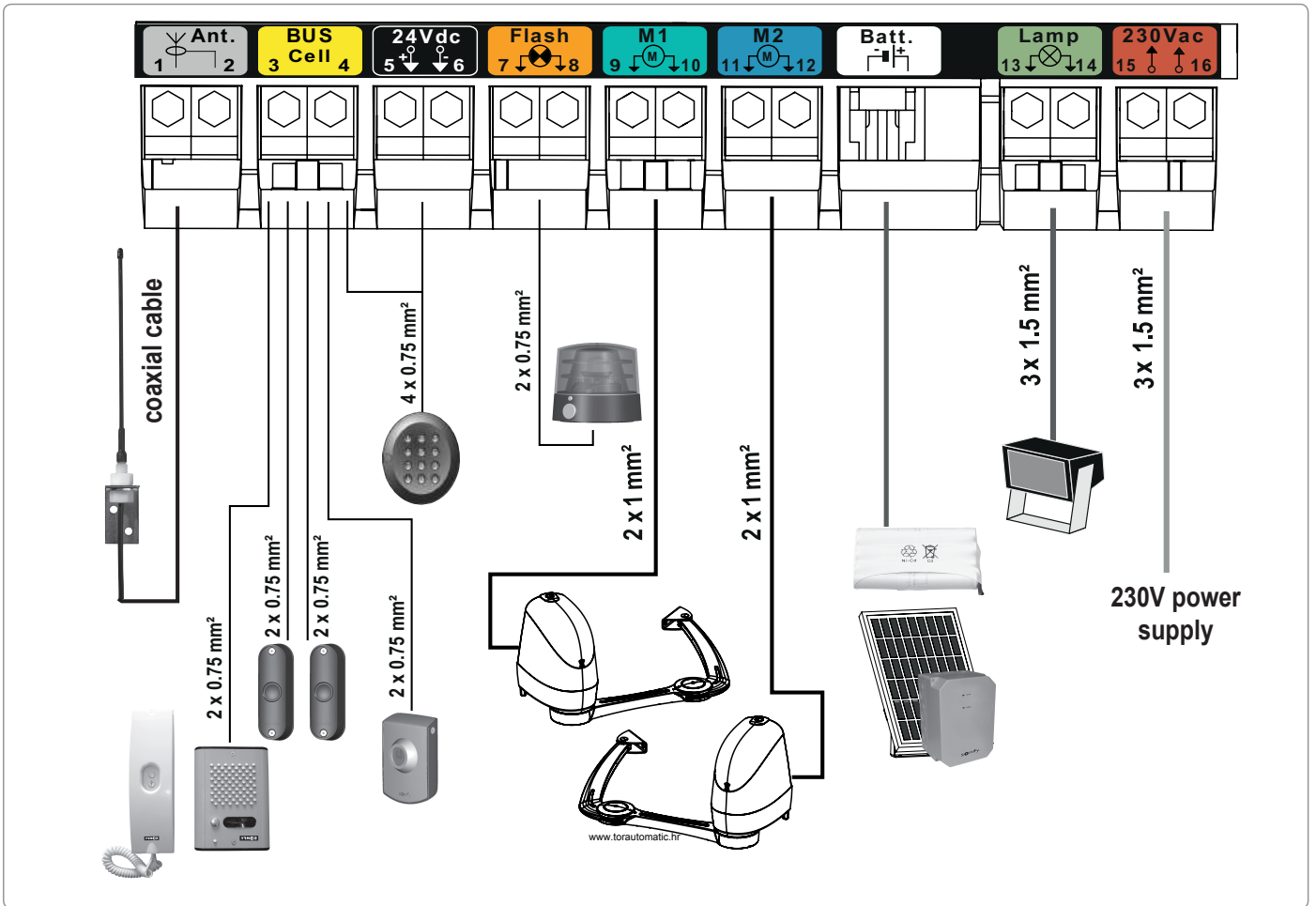

Connecting the photoelectric cells



Photoelectric cells must be connected to use the motor in automatic closing mode.

1 set of photoelectric cells

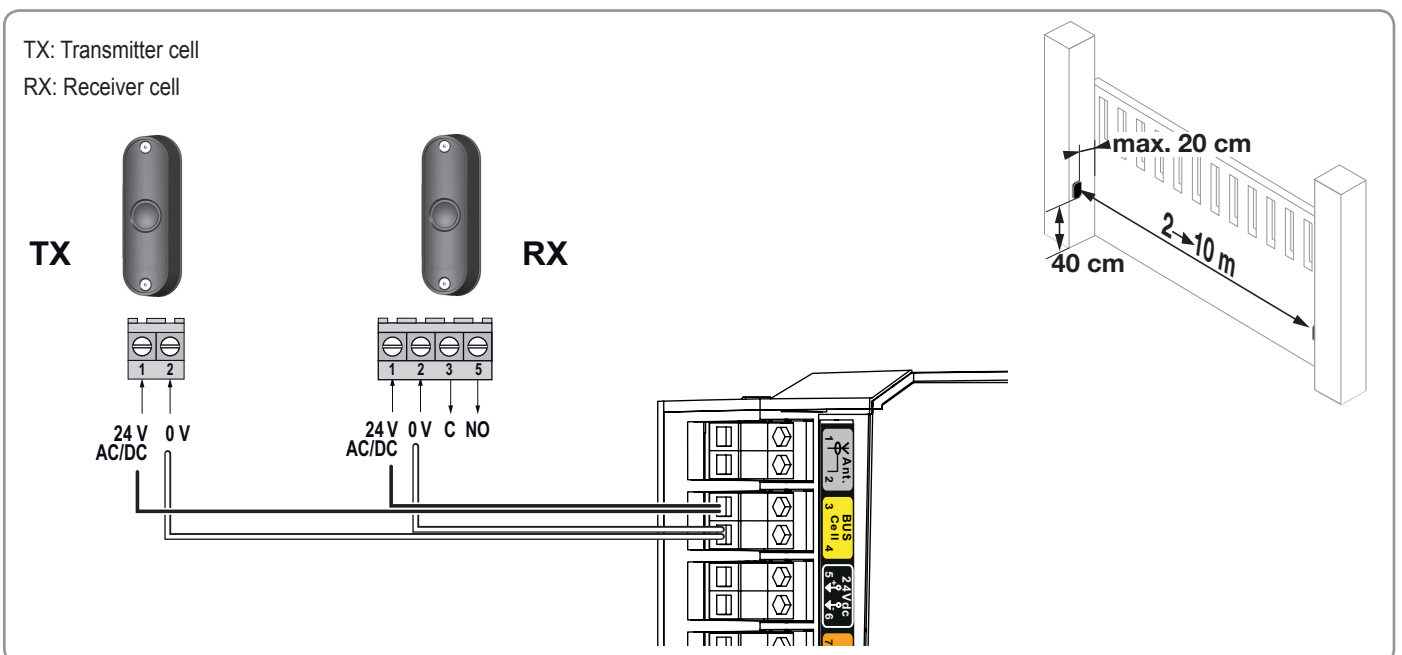

2 sets of photoelectric cells

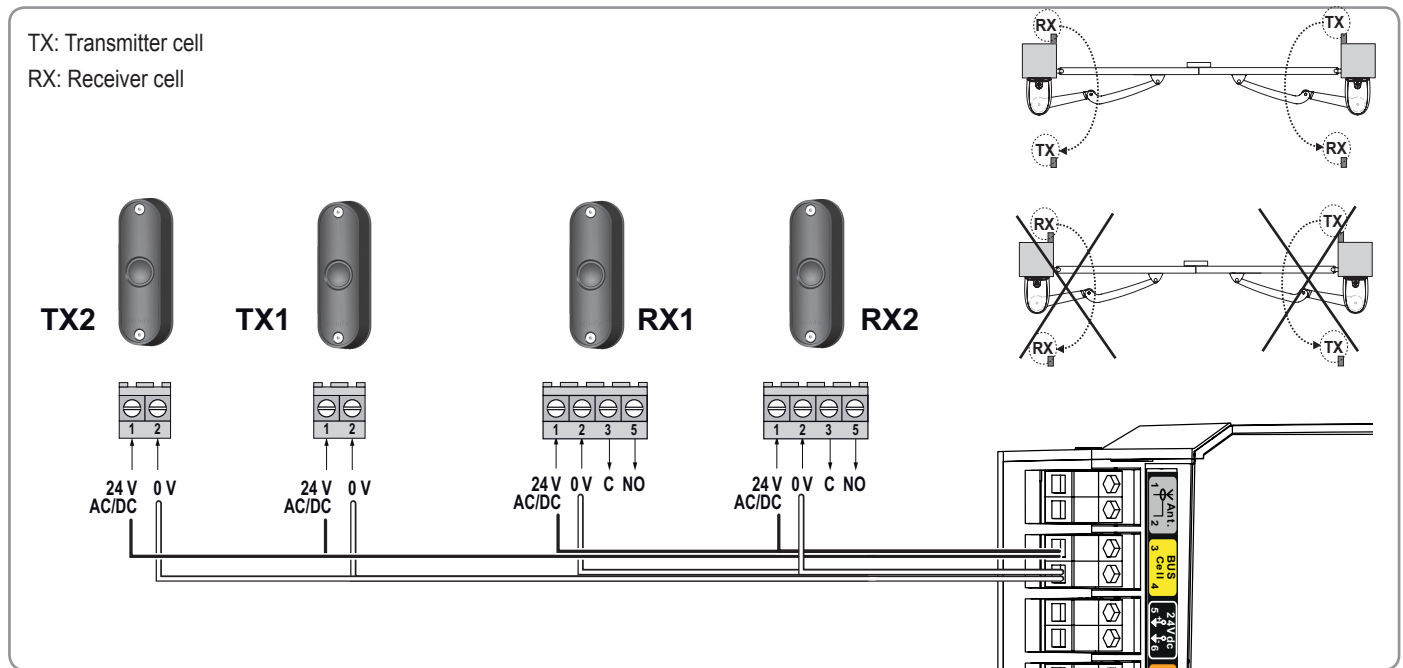

Recognition of the cells by the motor electronics

The cells are recognised by revalidating the motor's operating mode (sequential or automatic, see page 12), or by performing a new self-learning procedure (see page 11).

If the cells are removed

If the cells are disconnected:

- in sequential mode, repeat the motor electronics cell recognition procedure,
- in automatic closing mode, repeat the activation procedure for the automatic closing mode on page 12.

Blocking cells

www.torautomatic.hr

If the cells are blocked when closing the gate, the gate will stop and reverse its movement.

If the gate is closed and the cells are blocked, the gate will not open.

Orange light

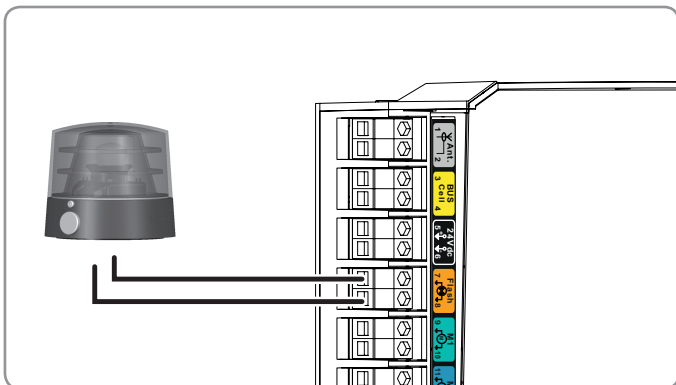

Exterior aerial

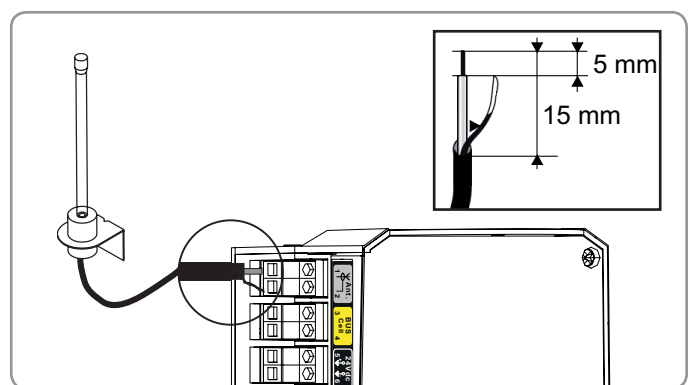

Key lock



This accessory is not compatible with solar power

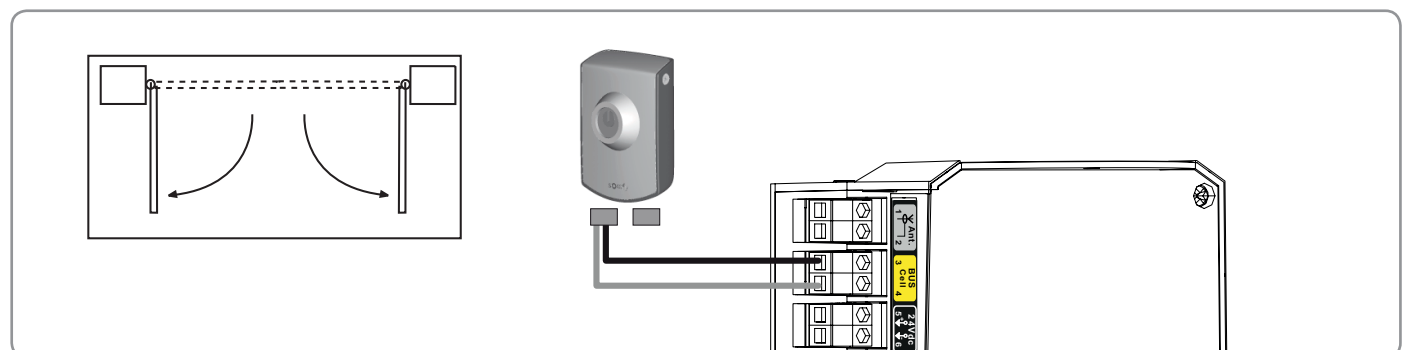

Intercom



*This accessory is not compatible with solar power.
The BUS input is a non-supplied dry contact control input.*

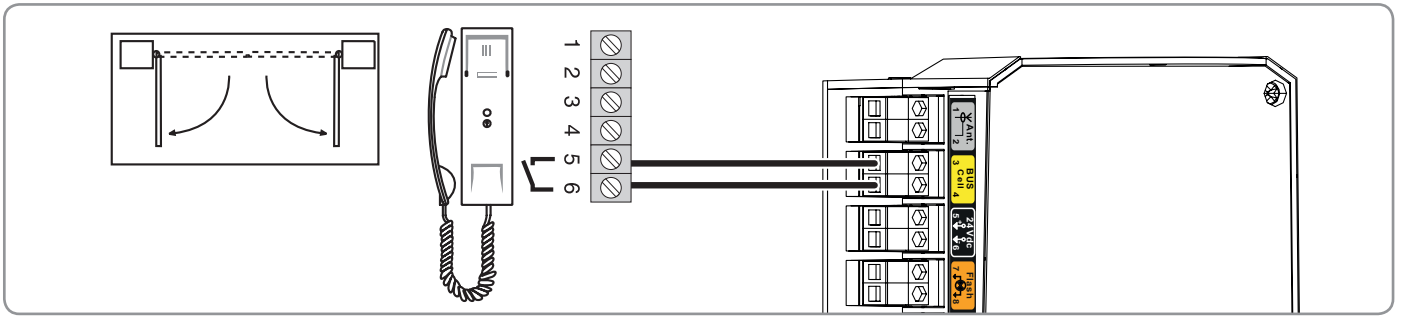

Backup battery

The backup battery enables the gate to operate (one leaf at a time) if there is a power outage.

It is integrated and connected directly to the motor's electronic unit.

To increase the operation time of the battery during use, the wired controls are deactivated and the gate can only be controlled using the remote controls and the radio control points.

The  indicator light flashes (1 pulse) when the motor is battery-operated.

Minimum charging time before first use: 48 hours

Operation time: 10 continuous cycles or 24 hours with a gate in perfect working order

Service life: 3 years (take worn batteries to the appropriate sites for proper disposal)



If there is a power cut and the backup battery is not charged, you will not be able to open your gate.

If your gate is the only entrance to your property, it is recommended to have a manual unlocking system fitted (ref 2400487). This will make it possible to enter the property and disengage the motors.

www.torautomatic.hr

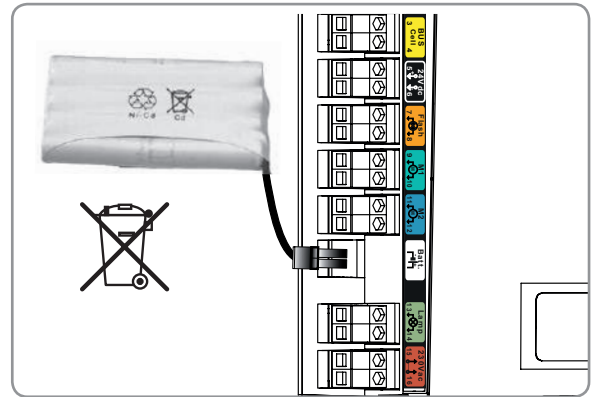

This accessory is not compatible with solar power.

Area lighting (500 W max with 230 V)

Area lighting comes on with the motor, and goes out 1 minute and 30 seconds after the motor has come to a complete stop.



This accessory is not compatible with solar power

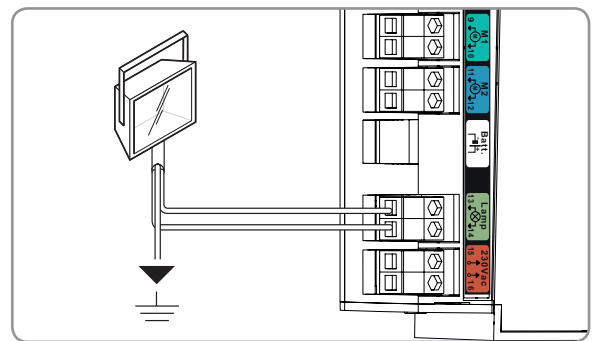

Digicode



This accessory is not compatible with solar power

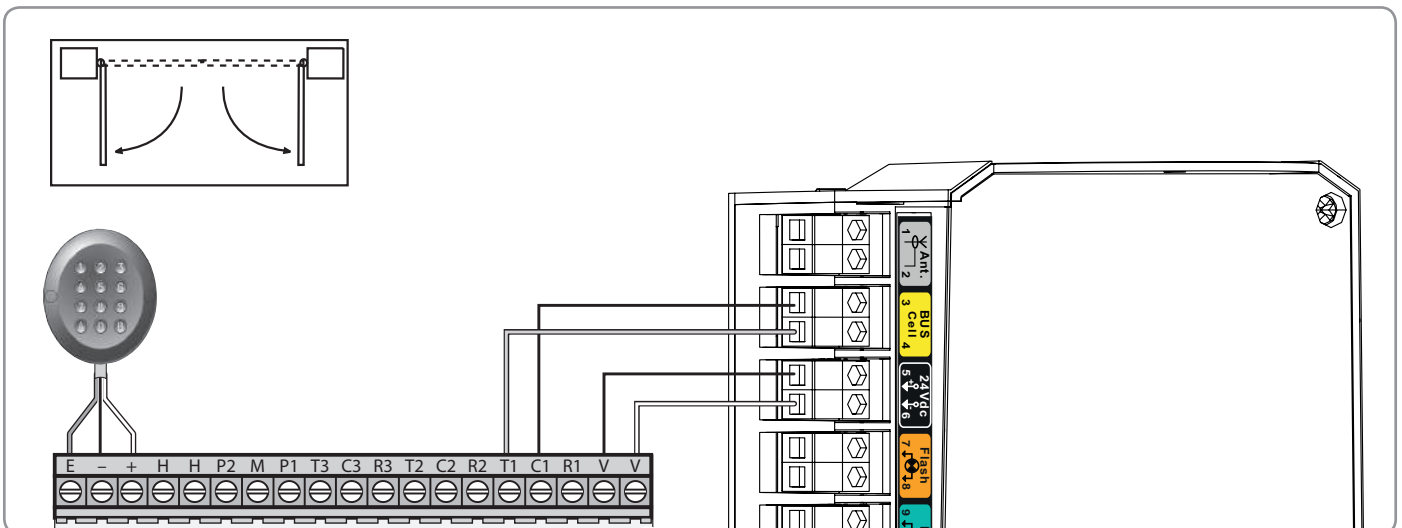

SOLAR POWER

 **Never connect your motor to a 230 V feed when it is connected to a solar feed, as this may damage the motor's electronics.**

When the motor is running on the solar feed:

- only the remote controls and radio control points can be used to control the gate (wired controls are deactivated),
- the wired safety accessories (photoelectric cells, orange light) remain active,
- the area lighting output and the 24V accessories output are deactivated.

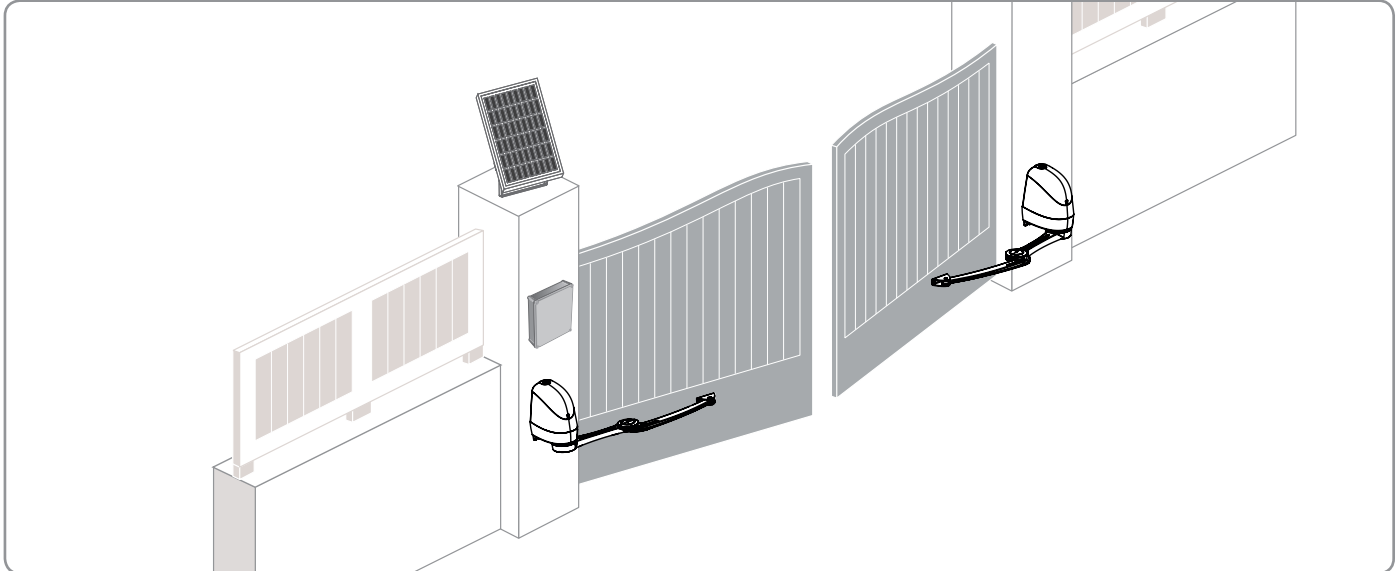

Connection to the solar power supply

Connect the solar power supply cable to the "BATT" terminal on the motor's electronic unit.

www.torautomatic.hr

Advice for use

If the gate is barred, we would suggest you protect the access to the arm from the outside of the property.

In order to limit the energy consumption of your gate motor, we recommend:

- the gate be closed to optimise the battery charge,
- the gate not be left open for more than 2 days,
- automatic gate closing be activated (see page 12).

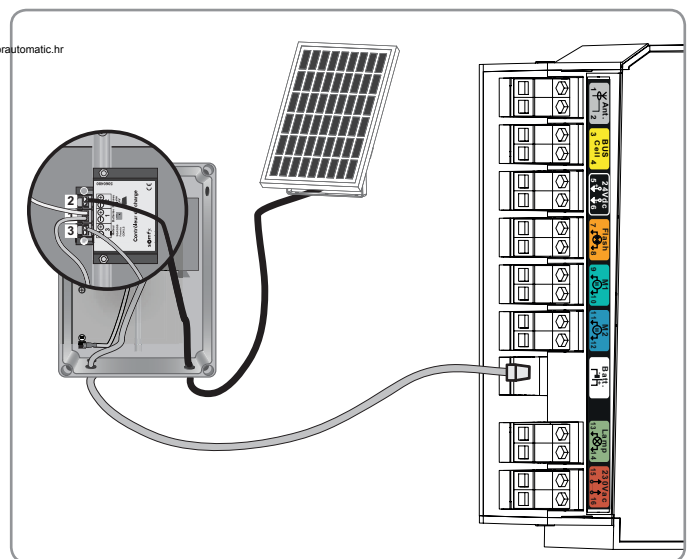

DIAGNOSTIC AND REPAIRS



Power the installation off during cleaning or other maintenance operations.

DIAGNOSTICS		REPAIRS	
The motors are not responding to remote control commands	The remote control range is reduced	<ul style="list-style-type: none"> - Check the remote control battery (see Replacing the battery, user section, page 4). - Check the aerial of the electronic unit (wiring, position, see page 9). - Check that there are no outside elements that are interfering with the radio signal (electricity pylon, metal reinforced walls, etc.). If this is the case, fit an external aerial. 	
	Remote control not memorised	Memorise the remote control (see page 10).	
	1 or 2 motors unlocked	Lock the motors.	
The control unit's indicator light is off	Motor not powered	<ul style="list-style-type: none"> - Check the power supply. - Check the power supply cable. 	
	Outdoor lighting very low = motor on standby	Increase the light around the electronic unit (e.g. using a torch) in order to perform the settings (see Ambient light detector below)	
The control unit's indicator light flashes:			
	1 pulse	Operation using the backup battery	Check the mains power supply.
	2 pulses	Motor awaiting gate travel self-learning	Start the gate travel self-learning procedure (see page 11).
	3 pulses	Cell fault:	
		- Cells blocked	Remove the obstacle blocking the cells.
		- Cells misaligned	Correct their alignment (see instructions supplied with the cells).
		- Cells incorrectly wired	Wire the cells following the instructions on page 13 or 14.
- Cells missing/disconnected	<ul style="list-style-type: none"> - Check that the cells are correctly connected. - If you have deliberately disconnected the cells and your gate is operating in automatic closing mode, deactivate automatic closing mode (see page 12). 		
4 pulses	Short circuit on the electronic unit BUS output (terminals 3-4)	Check the accessories connected to the electronic unit's BUS output.	
5 pulses	Electronics thermal safety activated	Allow the electronics to cool down until the indicator light comes on continuously.	
6 pulses	Short circuit on the control unit's 24 V output (terminals 5-6)	Check the accessory connected to the electronic unit's 24 V output.	
	Short circuit of orange light (terminals 7-8) on the control unit	Check the wiring of the orange light (see page 14).	
	Motor short circuit	Check the motor wiring (see page 9).	
The automatic closing mode is not activated (the indicator light stays off).	Photoelectric cells not installed	Install cells (see instructions supplied with the cells for the installation and page 13 for the wiring).	

Ambient light detector

The motor's electronic unit is fitted with an ambient light detector which detects whether or not the cover is fitted. This means that settings mode is only available when the cover is removed. If the cover is fitted, the motor is in standby mode.

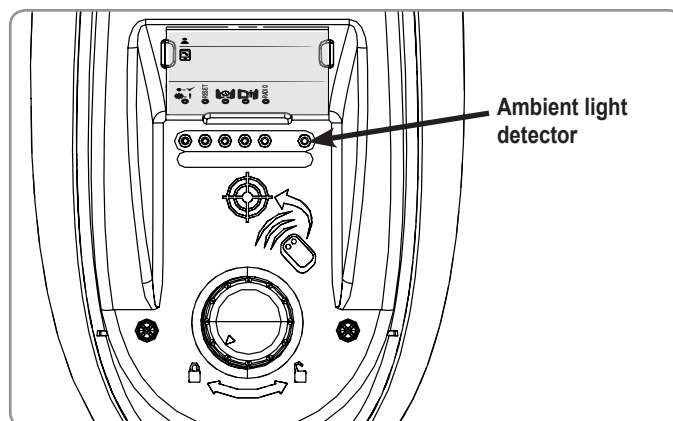

Clear the settings

The cleared settings are: the gate leaf travel and automatic closing of the gate.

When to clear the settings.

After the gate leaf travel has been programmed, if the opening stop setting or motor wiring has been modified.

In case of spurious obstacle detection because of normal wear on the gate.

[1]. Place a 2- or 4-button memorised remote control on the target engraved on the cover.

[2]. Press button 1 on the remote control until the  indicator light flashes.

[3]. Press button 1 on the remote control once.

The RESET indicator light flashes.

[4]. Press button 2 on the remote control until the RESET indicator light comes on.

Release button 2.

The  indicator light flashes.

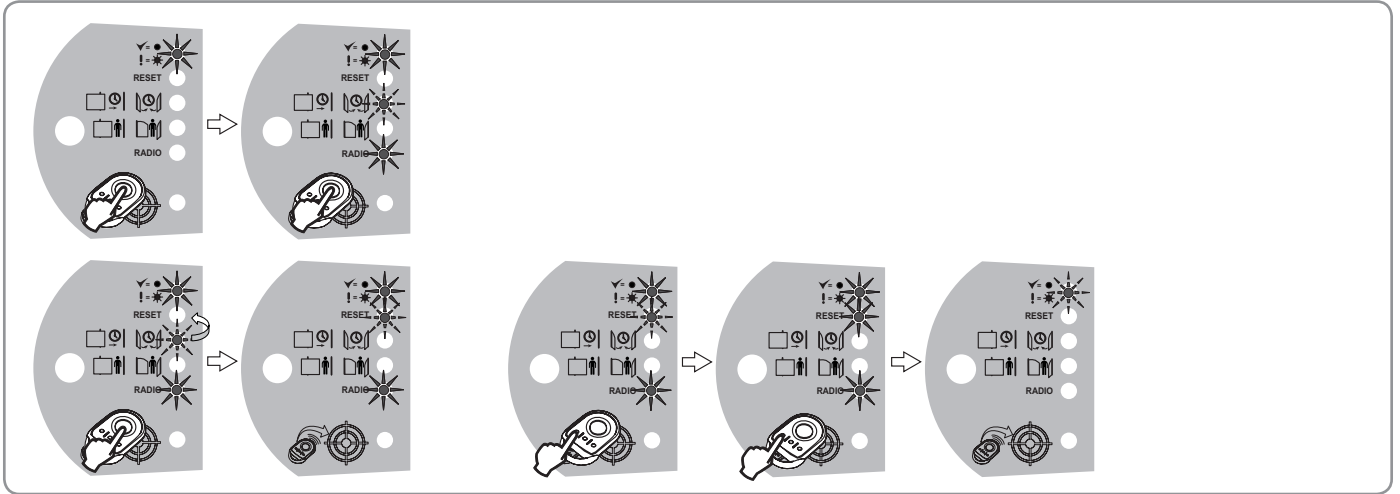

Clear the memorised settings and remote controls.

The cleared settings are: the gate leaf travel and automatic closing of the gate and all the memorised remote controls or radio control points.

[1]. Place a 2- or 4-button memorised remote control on the target engraved on the cover.

[2]. Press button 1 on the remote control until the  indicator light flashes.

[3]. Press button 1 on the remote control once.

The RESET indicator light flashes.

[4]. Press button 2 on the remote control until all the indicator lights come on.

Release button 2.

The  indicator light flashes.

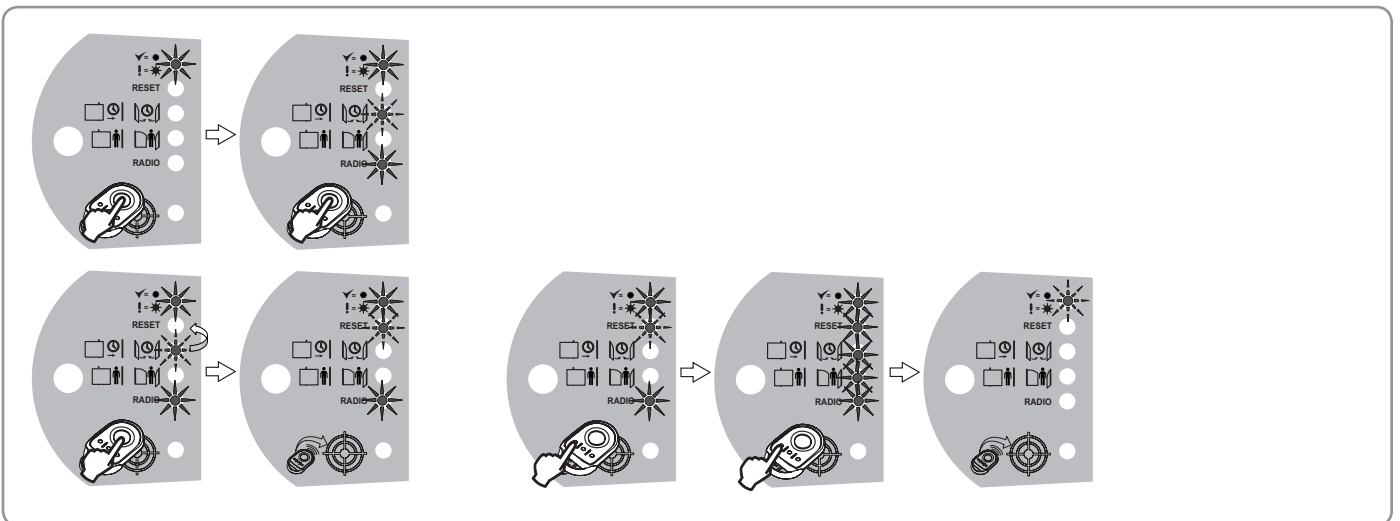

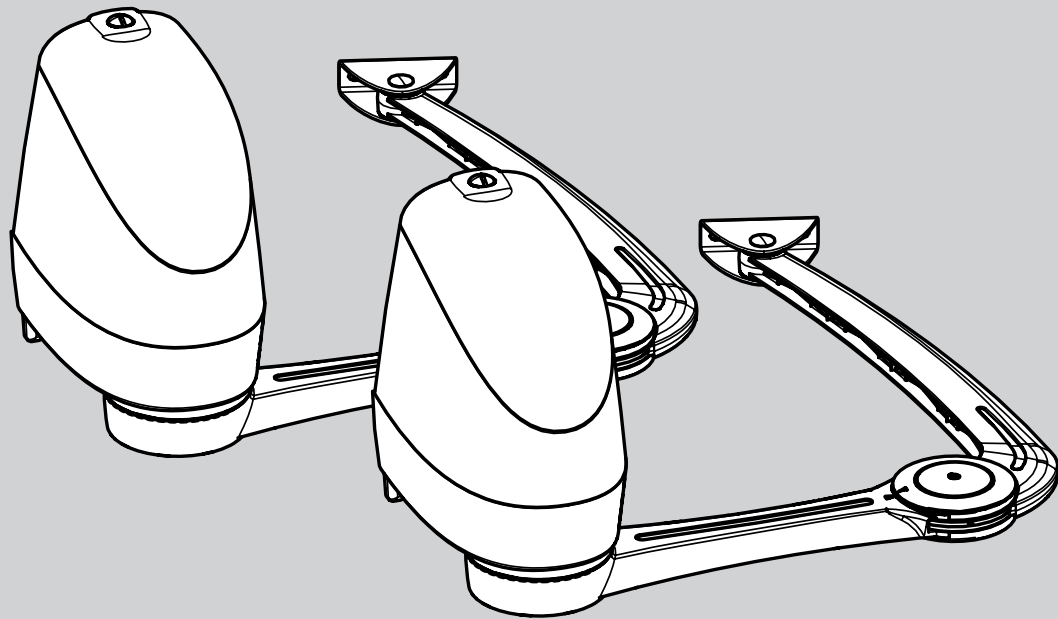

www.torautomatic.hr

Axovia 220B

User manual

CONTENTS

GENERAL INFORMATION	2
SAFETY INSTRUCTIONS	2
RECYCLING	2
USE AND OPERATION	3
MAINTENANCE	4



GENERAL INFORMATION

Thank you for choosing a SOMFY product. This equipment has been designed and manufactured by Somfy in accordance with a quality policy complying with the ISO 9001 standard.

About Somfy

Somfy develops, manufactures and sells automatic control devices for domestic opening and closing systems. We offer alarm systems, automatic control devices for awnings, roller shutters, garages and gates. We guarantee all Somfy products will meet your expectations in terms of safety, comfort and time saving on a daily basis.

At Somfy, the pursuit of quality is a continuous process of improvement. Somfy's reputation has been built upon the reliability of its products and the Somfy brand is synonymous with innovation and technological expertise worldwide.

Assistance

Getting to know our customers, listening to them, meeting their needs: this is Somfy's approach.

For further information on how to choose, purchase or install Somfy systems, please ask your Somfy installer for advice or contact a Somfy advisor directly for help and assistance.

As part of our policy of continuous innovation and improvement of our models, we reserve the right to make any modifications deemed necessary at any time. © SOMFY. Somfy SAS, with a capital 20.000.000 Euros, RCS Annecy 303.970.230

Declaration of Conformity

Somfy declares that this product complies with the essential requirements and other relevant provisions of Directive 1999/5/EC. A Declaration of Conformity is available at www.somfy.com/ce (Axovia 220B). Product can be used in the European Union and Switzerland.

SAFETY INSTRUCTIONS

Caution

If installed and used correctly, the motorisation system conforms to the required safety standards. It is recommended that these rules of conduct be respected to prevent the risk of danger or accidents. Before using the motorisation system, read the user guide carefully and keep it for future reference. Failure to comply with these instructions absolves Somfy of any liability resulting from damage that may be caused.

Any use outside the sphere of application specified by Somfy is forbidden. This invalidates the warranty and discharges Somfy of all liability, as does any failure to comply with the instructions given herein.

www.torautomatic.hr

Safety instructions relating to use

This device is not designed to be used by persons (including children) whose physical, sensory or mental capacity is impaired, or persons with little experience or knowledge, unless they are under supervision or have received instructions on using the device by a person responsible for their safety.

Monitor the movement of the gate and ensure that people are kept at a distance until the end of the movement.

Do not allow children to play with the gate control devices. Keep remote controls out of the reach of children. Children should be supervised to ensure they do not play with the device.

When using a switch without a locking device (for example: intercom, key contact, code keypad, etc.), ensure that other people remain at a distance.

Do not deliberately prevent the gate from moving.

In the event of incorrect operation, switch off the power supply, activate the emergency release to enable access and request assistance from a qualified technician (installer).

Do not attempt to open the gate manually unless the actuator has been unlocked. Manual unlocking may result in uncontrolled movement of the gate leaf.

Regularly check the condition of the gate. Gates in poor condition must be repaired, reinforced or even replaced. Do not use the motor if it needs repairing or adjusting

For all direct operations on the motorisation, please contact a qualified technician (installer).

Do not modify the motorisation components.

Have the motorisation checked every year by a qualified technician.

Never clean the motorisation system with high pressure water cleaning equipment.

Clean the photoelectric cell optical units and light signalling devices. Ensure that branches or shrubs do not obstruct the safety equipment (photoelectric cells).

RECYCLING



Do not throw away your scrapped equipment or used batteries with household waste. It is your responsibility to dispose of your electronic equipment in the relevant recycling points.



USE AND OPERATION

Default operation in sequential mode

By default, the gate will operate in sequential mode.

Operation in "complete opening" mode with a 2- or 4-button remote control (Fig. 1)

Press the programmed button to open the gate fully.

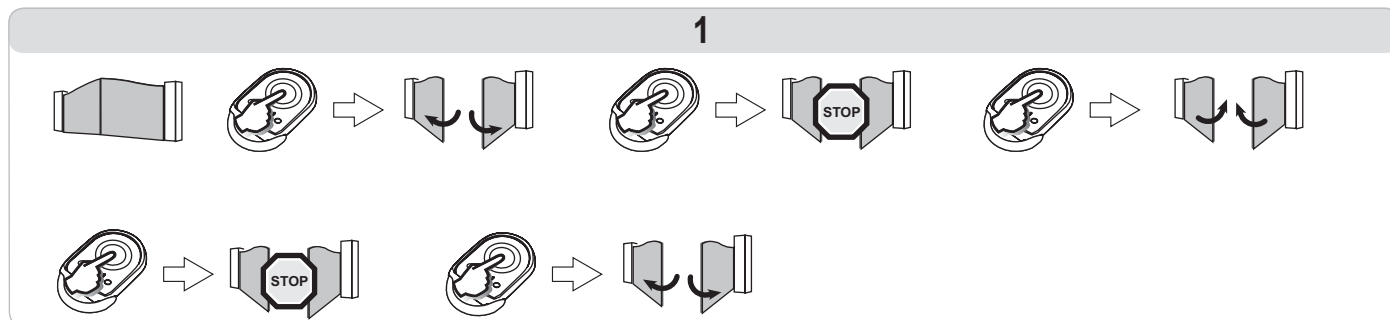

Operation in "pedestrian opening" mode with a 2- or 4-button remote control (Fig. 2)

Press the programmed button to open the gate in pedestrian mode.

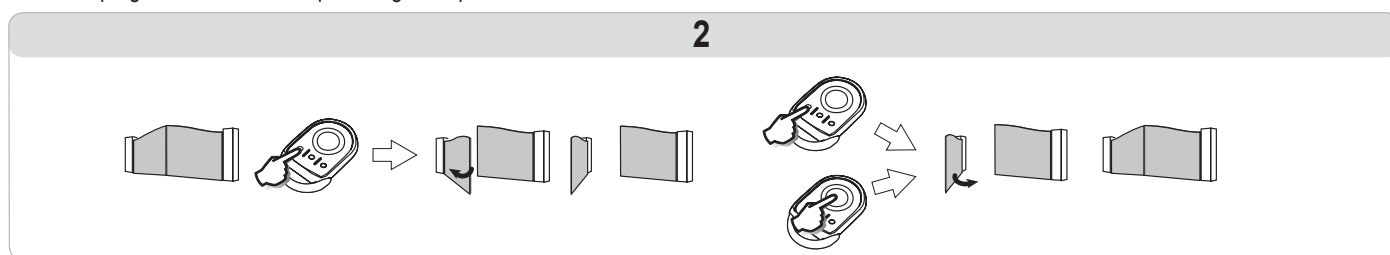

Operation in "complete opening" mode with a 3-button remote control (Fig. 3)

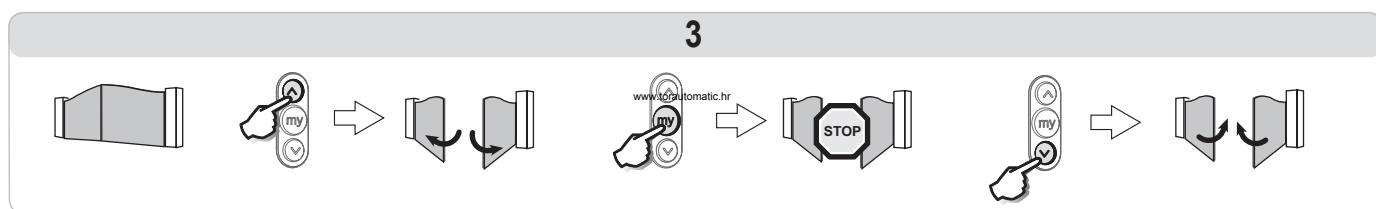

Operation in "pedestrian opening" mode with a 3-button remote control (Fig. 4)

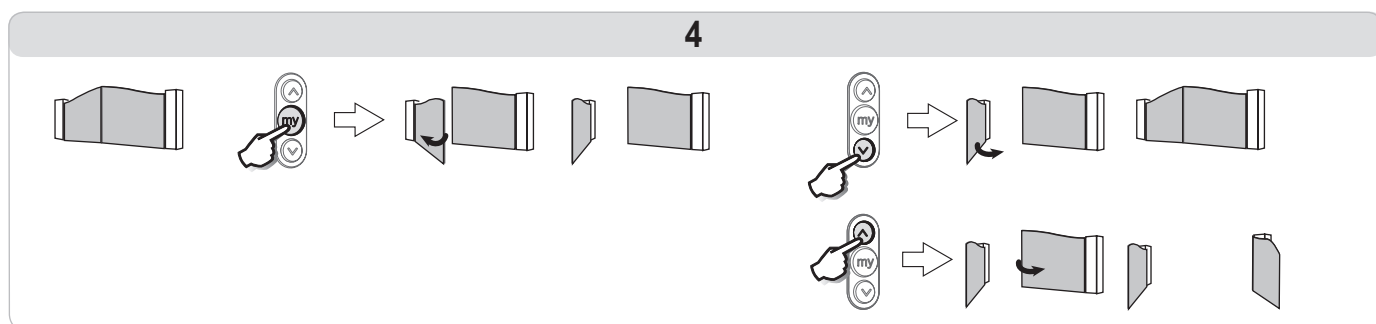

Obstacle detection operation

When an obstacle is detected during opening, the gate will stop. Pressing the programmed button on the remote control closes the gate.

If an obstacle is detected during closing, the gate will stop. Pressing the programmed button on the remote control reopens the gate.

Operation in automatic closing mode

If the automatic closing mode has been programmed during installation, the gate will operate as follows.

Pressing a programmed button on the remote control will cause the gate to open. The gate will close automatically after 30 seconds. If photoelectric cells are installed, any movement in front of the cells will cause the gate to close automatically after 5 seconds.

The gate can be held in the opened position by giving a stop command during the time delay. To close the gate, press the remote control button again.

Specific operation

Depending on the installed additional devices, the motorisation may operate in the following specific ways:

Operation with safety cells

Gate open: an obstacle placed between the cells will inhibit closing of the gate as the cells have detected a presence.

Gate moving: If an obstacle is detected while the gate is opening, the gate will continue moving (cell status not recognised).
If an obstacle is detected when closing, the gate will stop for 1 second and then reopen automatically.

Operation with orange flashing light

The orange light is activated during any movement of the gate with a 2 second warning.

Operation with area lighting

Area lighting comes on with the motor, and goes out 1 minute and 30 seconds after the motor has come to a complete stop.

Operation using the backup battery

If a backup battery is installed, the motorisation will work even during a power outage.

Operation is then activated under the following conditions:

- The gate leaves open one after the other at reduced speed.
- The additional devices (photoelectric cells, orange light, wired code keypad, etc.) do not operate.

Battery specifications:

- Life: 24 hrs; 10 operating cycles depending on the weight of the gate.
- Recharging time: 48 hours
- Service life before replacement: Approximately 3 years.

For optimum battery life it is recommended that the main power supply be switched off and the motor operated using the battery for several cycles, three times a year.

Manual back release

In case of a power cut, the manual back release device makes it possible to open the gate.

Unlock the motor arms by turning the button located underneath the motors.

Padlock closed: arm locked; **padlock open:** arm unlocked, manual operation.

 **In unlocked position, move the arms slowly to avoid damaging the motors.**

www.torautomatic.hr

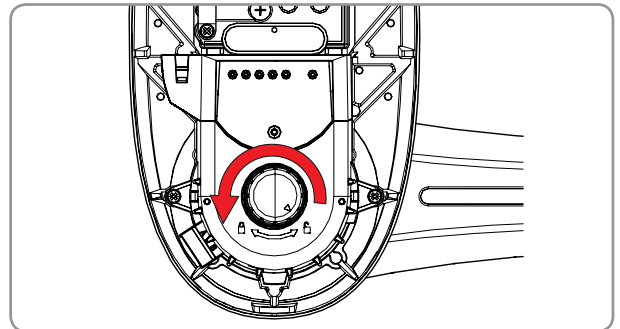

MAINTENANCE

Checks

Safety devices (cells)

Check for correct operation every 6 months (see page 4).

Backup battery

For optimum battery life, it is recommended that the main power supply be switched off and the motor operated using the battery for several cycles, three times a year. Contact a qualified person (installer) to have the backup battery replaced.

Replacing the battery

Keytis RTS (Fig. 5)

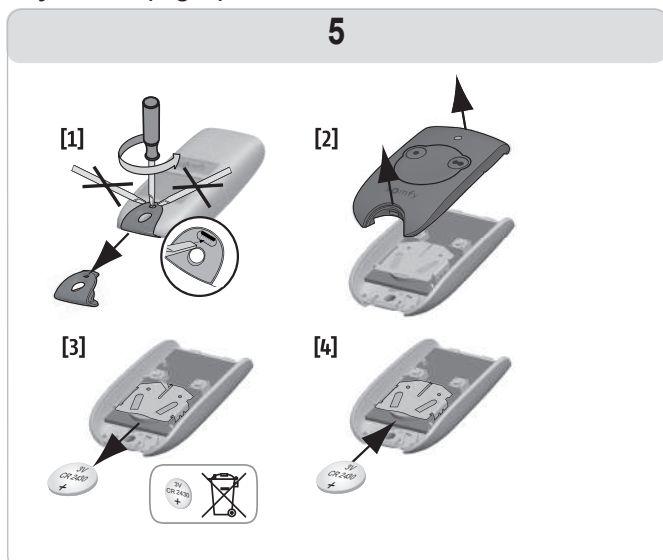

Keygo RTS (Fig. 6)

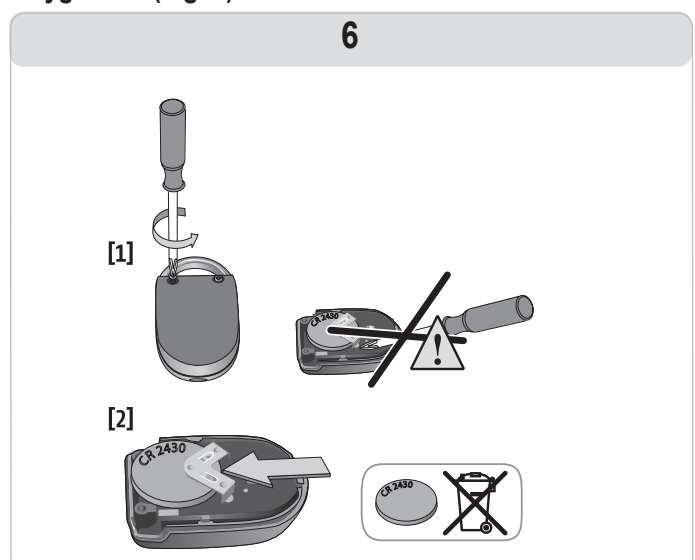

www.torautomatic.hr

Somfy

50 avenue du Nouveau Monde
BP 152 - 74307 Cluses Cedex
France
T +33 (0)4 50 96 70 00
F +33 (0)4 50 96 71 89

www.somfy.com

Somfy Worldwide

Argentina : Somfy Argentina

+55 11 (0) 4737-37000

Australia : Somfy PTY LTD

+61 (0) 2 9638 0744

Austria : Somfy GesmbH

+43(0) 662 / 62 53 08 - 0

Belgium : Somfy Belux

+32 (0)2 712 07 70

Brasil : Somfy Brasil STDA

+55 11 (0) 6161 6613

Canada : Somfy ULC

+1 (0) 905 564 6446

China : Somfy China Co. Ltd

+8621 (0) 6280 9660

Cyprus : Somfy Middle East

+357 (0) 25 34 55 40

Czech Republic : Somfy Spol s.r.o.

(+420) 296 372 486-7

Denmark : Somfy Nordic AB Denmark

+45 65 32 57 93

Finland : Somfy Nordic AB Finland

+358 (0) 957 13 02 30

France : Somfy France

+33 (0) 820 374 374

Germany : Somfy GmbH

+49 (0) 7472 9300

Greece : Somfy Hellas

+30 210 614 67 68

Hong Kong : Somfy Co. Ltd

+852 (0) 2523 6339

Hungary : Somfy Kft

+36 1814 5120

India : Somfy India PVT Ltd

+91 (0) 11 51 65 91 76

Indonesia : Somfy IndonesiaEra

+62 (0) 21 719 3620

Iran : Somfy Iran

+98 21 88 63 52 43

Israel : Sisa Home Automation Ltd

+972 (0) 3 952 55 54

Italy : Somfy Italia s.r.l

+39-024 84 71 84

Japan : Somfy KK

+81 (0)45-475-0732

+81 (0)45-475-0922

Jordan : Somfy Jordan

+962-6-5821615

Kingdom of Saudi Arabia :

Somfy Saoudi

Riyadh : +966 1 47 23 203

Jeddah : +966 2 69 83 353

Kuwait : Somfy Kuwait

00965 4348906

Lebanon : Somfy Middle East

+961(0) 1 391 224

Malaysia : Somfy Malaysia

+60 (0) 3 228 74743

Mexico : Somfy Mexico SA de CV

+52(0) 55 5576 3421

Morocco : Somfy Maroc

+212-22951153

Netherlands : Somfy BV

+31 (0) 23 55 44 900

Norway : Somfy Norway

+47 67 97 85 05

Poland : Somfy SP Z.O.O

+48 (0) 22 509 53 00

Portugal : Somfy Portugal

+351 229 396 840

Romania : Somfy SRL

+40 - (0)368 - 444 081

Russia : Somfy LLC

+7 095 781 47 72

Singapore : Somfy PTE LTD

+65 (0) 638 33 855

Slovak Republic : Somfy Spol s.r.o.

(+421) 33 77 18 638

South Korea : Somfy JOO

+82 (0) 2 594 4333

Spain : Somfy Espana SA

+34 (0) 934 800 900

Sweden : Somfy Nordic AB

+46 (0) 40 165900

Switzerland : Somfy A.G.

+41 (0) 44 838 40 30

Syria : Somfy Syria

+963-9-55580700

Taiwan : Somfy Taiwan

+886 (0) 2 8509 8934

Thailand : Somfy Thailand

+66 (0) 2714 3170

Turkey : Somfy Turkey

+90 (0) 216 651 30 15

United Arab Emirates : Somfy Gulf

+971 (0) 4 88 32 808

United Kingdom : Somfy LTD

+44 (0) 113 391 3030

United States : Somfy Systems Inc

+1 (0) 609 395 1300