

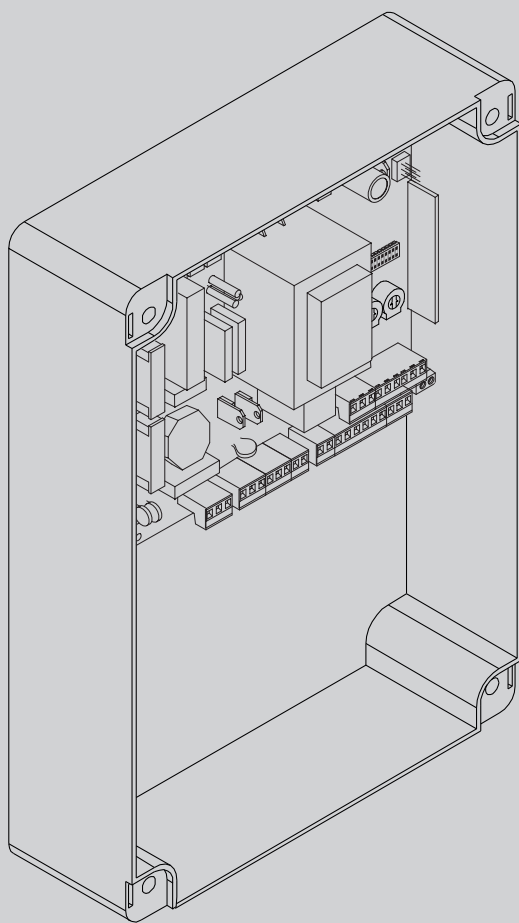

ac

D812801 00100_01 19-09-16

QUADRO COMANDO
CONTROL PANEL
CENTRALE DE COMMANDE
SELBSTÜBERWACHENDE STEUERUNG
CUADRO DE MANDOS
BEDIENINGSPANEEL



ISTRUZIONI DI INSTALLAZIONE
INSTALLATION MANUAL
INSTRUCTIONS D'INSTALLATION
MONTAGEANLEITUNG
INSTRUCCIONES DE INSTALACION
INSTALLATIEVOORSCHRIFTEN

ALENA SW2 CP EM

TORAUTOMATIC
Put Loparica 23
10020 ZAGREB

www.torautomatic.hr
info@torautomatic.hr



AZIENDA CON SISTEMA DI GESTIONE
INTEGRATO CERTIFICATO DA DNV
= UNI EN ISO 9001:2008 =
UNI EN ISO 14001:2004

Attenzione! Leggere attentamente le "Avvertenze" all'interno! **Caution!** Read "Warnings" inside carefully! **Attention!** Veuillez lire attentivement les Avertissements qui se trouvent à l'intérieur! **Achtung!** Bitte lesen Sie aufmerksam die „Hinweise“ im Inneren! ¡**Atención!** Leer atentamente las "Advertencias" en el interior! **Let op!** Lees de "Waarschuwingen" aan de binnenkant zorgvuldig!

www.torautomatic.hr

INSTALLER WARNINGS

WARNING! Important safety instructions. Carefully read and comply with all the warnings and instructions that come with the product as incorrect installation can cause injury to people and animals and damage to property. The warnings and instructions give important information regarding safety, installation, use and maintenance. Keep hold of instructions so that you can attach them to the technical file and keep them handy for future reference.

GENERAL SAFETY

This product has been designed and built solely for the purpose indicated herein. Uses other than those indicated herein might cause damage to the product and create a hazard.

- The units making up the machine and its installation must meet the requirements of the following European Directives, where applicable: 2014/30/EC, 2014/35/EC, 2006/42/EC, 2011/305/EC, 99/05/EC and later amendments. For all countries outside the EEC, it is advisable to comply with the standards mentioned, in addition to any national standards in force, to achieve a good level of safety.
- The Manufacturer of this product (hereinafter referred to as the "Firm") disclaims all responsibility resulting from improper use or any use other than that for which the product has been designed, as indicated herein, as well as for failure to apply Good Practice in the construction of entry systems (doors, gates, etc.) and for deformation that could occur during use.
- Installation must be carried out by qualified personnel (professional installer, according to EN 12635), in compliance with Good Practice and current code.
- Before installing the product, make all structural changes required to produce safety gaps and to provide protection from or isolate all crushing, shearing and dragging hazard areas and danger zones in general in accordance with the provisions of standards EN 12604 and 12453 or any local installation standards. Check that the existing structure meets the necessary strength and stability requirements.
- Before commencing installation, check the product for damage.
- The Firm is not responsible for failure to apply Good Practice in the construction and maintenance of the doors, gates, etc. to be motorized, or for deformation that might occur during use.
- Make sure the stated temperature range is compatible with the site in which the automated system is due to be installed.
- Do not install this product in an explosive atmosphere: the presence of flammable fumes or gas constitutes a serious safety hazard.
- Disconnect the electricity supply before performing any work on the system. Also disconnect buffer batteries, if any are connected.
- Before connecting the power supply, make sure the product's ratings match the mains ratings and that a suitable residual current circuit breaker and overcurrent protection device have been installed upline from the electrical system. Have the automated system's mains power supply fitted with a switch or omnipolar thermal-magnetic circuit breaker with a contact separation that provide full disconnection under overvoltage category III conditions.
- Make sure that upline from the mains power supply there is a residual current circuit breaker that trips at no more than 0.03A as well as any other equipment required by code.
- Make sure the earth system has been installed correctly: earth all the metal parts belonging to the entry system (doors, gates, etc.) and all parts of the system featuring an earth terminal.
- Installation must be carried out using safety devices and controls that meet standards EN 12978 and EN 12453.
- Impact forces can be reduced by using deformable edges.
- In the event impact forces exceed the values laid down by the relevant standards, apply electro-sensitive or pressure-sensitive devices.
- Apply all safety devices (photocells, safety edges, etc.) required to keep the area free of impact, crushing, dragging and shearing hazards. Bear in mind the standards and directives in force, Good Practice criteria, intended use, the installation environment, the operating logic of the system and forces generated by the automated system.
- Apply all signs required by current code to identify hazardous areas (residual risks). All installations must be visibly identified in compliance with the provisions of standard EN 13241-1.
- Once installation is complete, apply a nameplate featuring the door/gate's data.
- This product cannot be installed on leaves incorporating doors (unless the motor can be activated only when the door is closed).
- If the automated system is installed at a height of less than 2.5 m or is accessible, the electrical and mechanical parts must be suitably protected.
- For roller shutter automation only
 - 1) The motor's moving parts must be installed at a height greater than 2.5 m above the floor or other surface from which they may be reached.
 - 2) The gearmotor must be installed in a segregated and suitably protected space so that it cannot be reached without the aid of tools.
- Install any fixed controls in a position where they will not cause a hazard, away from moving parts. More specifically, hold-to-run controls must be positioned within direct sight of the part being controlled and, unless they are key operated, must be installed at a height of at least 1.5 m and in a place where they cannot be reached by the public.
- Apply at least one warning light (flashing light) in a visible position, and also attach a Warning sign to the structure.
- Attach a label near the operating device, in a permanent fashion, with information on how to operate the automated system's manual release.
- Make sure that, during operation, mechanical risks are avoided or relevant protective measures taken and, more specifically, that nothing can be banged, crushed, caught or cut between the part being operated and surrounding parts.
- Once installation is complete, make sure the motor automation settings are correct and that the safety and release systems are working properly.
- Only use original spare parts for any maintenance or repair work. The Firm disclaims all responsibility for the correct operation and safety of the automated system if parts from other manufacturers are used.
- Do not make any modifications to the automated system's components unless explicitly authorized by the Firm.
- Instruct the system's user on what residual risks may be encountered, on the control systems that have been applied and on how to open the system manually in an emergency. Give the user guide to the end user.

-Dispose of packaging materials (plastic, cardboard, polystyrene, etc.) in accordance with the provisions of the laws in force. Keep nylon bags and polystyrene out of reach of children.

WIRING

WARNING! For connection to the mains power supply, use a multicore cable with a cross-sectional area of at least 5x1.5mm² or 4x1.5mm² when dealing with three-phase power supplies or 3x1.5mm² for single-phase supplies (by way of example, type H05RN-F cable can be used with a cross-sectional area of 4x1.5mm²). To connect auxiliary equipment, use wires with a cross-sectional area of at least 0.5 mm².

- Only use pushbuttons with a capacity of 10A-250V or more.
- Wires must be secured with additional fastening near the terminals (for example, using cable clamps) in order to keep live parts well separated from safety extra low voltage parts.
- During installation, the power cable must be stripped to allow the earth wire to be connected to the relevant terminal, while leaving the live wires as short as possible. The earth wire must be the last to be pulled taut in the event the cable's fastening device comes loose.

WARNING! safety extra low voltage wires must be kept physically separate from low voltage wires.

Only qualified personnel (professional installer) should be allowed to access live parts.

CHECKING THE AUTOMATED SYSTEM AND MAINTENANCE

Before the automated system is finally put into operation, and during maintenance work, perform the following checks meticulously:

- Make sure all components are fastened securely.
- Check starting and stopping operations in the case of manual control.
- Check the logic for normal or personalized operation.
- For sliding gates only: check that the rack and pinion mesh correctly with 2 mm of play along the full length of the rack; keep the track the gate slides on clean and free of debris at all times.
- For sliding gates and doors only: make sure the gate's running track is straight and horizontal and that the wheels are strong enough to take the weight of the gate.
- For cantilever sliding gates only: make sure there is no dipping or swinging during operation.
- For swing gates only: make sure the leaves' axis of rotation is perfectly vertical.
- For barriers only: before opening the door, the spring must be decompressed (vertical boom).
- Check that all safety devices (photocells, safety edges, etc.) are working properly and that the anti-crush safety device is set correctly, making sure that the force of impact measured at the points provided for by standard EN 12445 is lower than the value laid down by standard EN 12453.
- Impact forces can be reduced by using deformable edges.
- Make sure that the emergency operation works, where this feature is provided.
- Check opening and closing operations with the control devices applied.
- Check that electrical connections and cabling are intact, making extra sure that insulating sheaths and cable glands are undamaged.
- While performing maintenance, clean the photocells' optics.
- When the automated system is out of service for any length of time, activate the emergency release (see "EMERGENCY OPERATION" section) so that the operated part is made idle, thus allowing the gate to be opened and closed manually.
- If the power cord is damaged, it must be replaced by the manufacturer or their technical assistance department or other such qualified person to avoid any risk.
- If "D" type devices are installed (as defined by EN12453), connect in unverified mode, foresee mandatory maintenance at least every six months
- The maintenance described above must be repeated at least once yearly or at shorter intervals where site or installation conditions make this necessary.

WARNING!

Remember that the drive is designed to make the gate/door easier to use and will not solve problems as a result of defective or poorly performed installation or lack of maintenance



SCRAPPING

Materials must be disposed of in accordance with the regulations in force. Do not throw away your discarded equipment or used batteries with household waste. You are responsible for taking all your waste electrical and electronic equipment to a suitable recycling centre.

DISMANTLING

If the automated system is being dismantled in order to be reassembled at another site, you are required to:

- Cut off the power and disconnect the whole electrical system.
- Remove the actuator from the base it is mounted on.
- Remove all the installation's components.
- See to the replacement of any components that cannot be removed or happen to be damaged.

**DECLARATIONS OF CONFORMITY CAN BE FOUND AT <http://www.bft-automation.com/CE>
INSTRUCTIONS FOR USE AND ASSEMBLY CAN BE FOUND IN THE DOWN-LOAD SECTION.**

Anything that is not explicitly provided for in the installation manual is not allowed. The operator's proper operation can only be guaranteed if the information given is complied with. The Firm shall not be answerable for damage caused by failure to comply with the instructions featured herein.

While we will not alter the product's essential features, the Firm reserves the right, at any time, to make those changes deemed opportune to improve the product from a technical, design or commercial point of view, and will not be required to update this publication accordingly.

purpose for which it was explicitly installed. Any other use constitutes improper use and, consequently, is hazardous. The manufacturer cannot be held liable for any damage as a result of improper, incorrect or unreasonable use.

GENERAL SAFETY

Thank you for choosing this product. The Firm is confident that its performance will meet your operating needs.

This product meets recognized technical standards and complies with safety provisions when installed correctly by qualified, expert personnel (professional installer).

If installed and used correctly, the automated system will meet operating safety standards. Nonetheless, it is advisable to observe certain rules of behaviour so that accidental problems can be avoided:

- Keep adults, children and property out of range of the automated system, especially while it is moving.
- Do not allow children to play or stand within range of the automated system.
- The unit can be used by children over 8 years old and by people with reduced physical, sensory or mental capabilities or with no experience or necessary knowledge on condition they are supervised or trained about the safe use of the equipment and understand the risks involved. Children must not play with the unit. Cleaning and maintenance must not be performed by unsupervised children.
- Children must be supervised to ensure they do not play with the device. Do not allow children to play with the fixed controls. Keep remote controls out of reach of children.
- Do not work near hinges or moving mechanical parts.
- Do not hinder the leaf's movement and do not attempt to open the door manually unless the actuator has been released with the relevant release knob.
- Keep out of range of the motorized door or gate while they are moving.
- Keep remote controls or other control devices out of reach of children in order to avoid the automated system being operated inadvertently.
- The manual release's activation could result in uncontrolled door movements if there are mechanical faults or loss of balance.
- When using roller shutter openers: keep an eye on the roller shutter while it is moving and keep people away until it has closed completely. Exercise care when activating the release, if such a device is fitted, as an open shutter could drop quickly in the event of wear or breakage.
- The breakage or wear of any mechanical parts of the door (operated part), such as cables, springs, supports, hinges, guides..., may generate a hazard. Have the system checked by qualified, expert personnel (professional installer) at regular intervals according to the instructions issued by the installer or manufacturer of the door.
- When cleaning the outside, always cut off mains power.
- Keep the photocells' optics and illuminating indicator devices clean. Check that no branches or shrubs interfere with the safety devices.
- Do not use the automated system if it is in need of repair. In the event the automated system breaks down or malfunctions, cut off mains power to the system; do not attempt to repair or perform any other work to rectify the fault yourself and instead call in qualified, expert personnel (professional

installer) to perform the necessary repairs or maintenance. To allow access, activate the emergency release (where fitted).

- If any part of the automated system requires direct work of any kind that is not contemplated herein, employ the services of qualified, expert personnel (professional installer).
- At least once a year, have the automated system, and especially all safety devices, checked by qualified, expert personnel (professional installer) to make sure that it is undamaged and working properly.
- A record must be made of any installation, maintenance and repair work and the relevant documentation kept and made available to the user on request.
- Failure to comply with the above may result in hazardous situations.



SCRAPPING

Materials must be disposed of in accordance with the regulations in force. Do not throw away your discarded equipment or used batteries with household waste. You are responsible for taking all your waste electrical and electronic equipment to a suitable recycling centre.

Anything that is not explicitly provided for in the user guide is not allowed. The operator's proper operation can only be guaranteed if the instructions given herein are complied with. The Firm shall not be answerable for damage caused by failure to comply with the instructions featured herein.

While we will not alter the product's essential features, the Firm reserves the right, at any time, to make those changes deemed opportune to improve the product from a technical, design or commercial point of view, and will not be required to update this publication accordingly.

AVERTISSEMENTS POUR L'UTILISATEUR (F)

ATTENTION ! Instructions de sécurité importantes. Veuillez lire et suivre attentivement tous les avertissements et toutes les instructions fournis avec le produit sachant qu'un usage incorrect peut provoquer des préjudices aux personnes, aux animaux ou aux biens. Veuillez conserver les instructions pour d'ultérieures consultations et pour les transmettre aux propriétaires futurs éventuels.

Cet appareil ne peut être destiné qu'à l'usage pour lequel il a été expressément installé. Tout autre usage sera considéré comme impropre et donc dangereux. Le fabricant ne sera en aucun cas considéré comme responsable des préjudices dus à un usage impropre, erroné ou déraisonné.

SECURITE GÉNÉRALE

Nous vous remercions d'avoir choisi ce produit qui, nous n'en doutons pas, saura vous garantir les performances attendues.

Ce produit, correctement installé par du personnel qualifié et expérimenté (monteur professionnel) est conforme aux normes reconnues de la technique et des prescriptions de sécurité.

Si l'automatisation est montée et utilisée correctement, elle garantit la sécurité d'utilisation prescrite. Il est cependant nécessaire de respecter certaines règles de comportement pour éviter tout inconvénient accidentel.

INSTALLAZIONE VELOCE-QUICK INSTALLATION INSTALLATION RAPIDE - INSTALACIÓN RÁPIDA

D812801 00100_01

**PREDISPOSIZIONE TUBI, TUBE ARRANGEMENT,
PRÉDISPOSITION DES TUYAUX, VORBEREITUNG DER LEITUNGEN,
DISPOSICIÓN DE TUBOS, VOORBEREIDING LEIDINGEN.**

A

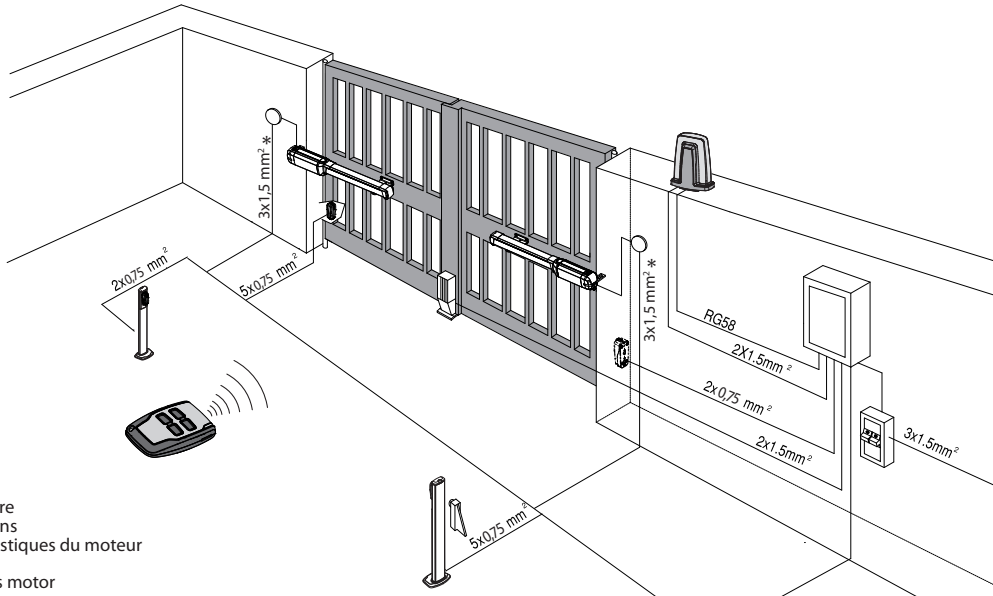

Vedere specifica motore
See motor specifications
Consultez les caractéristiques du moteur
Siehe Motordaten
Véase especificaciones motor
Zie motorspecificatie

**DIP SWITCH + TRIMMER + TASTI PROGRAMMAZIONE
DIP SWITCH + TRIMMER + PROGRAMMING KEYS
COMMUTATEURS DIP + DÉCLENCHEURS + TOUCHES PROGRAMMATION
DIP SWITCH + TRIMMER + PROGRAMMIERUNGSTÄSTEN
DIP SWITCH + TRIMMER + BOTONES PROGRAMACIÓN
DIP SWITCHES + TRIMMERS + PROGRAMMINGSTOETSEN**

B

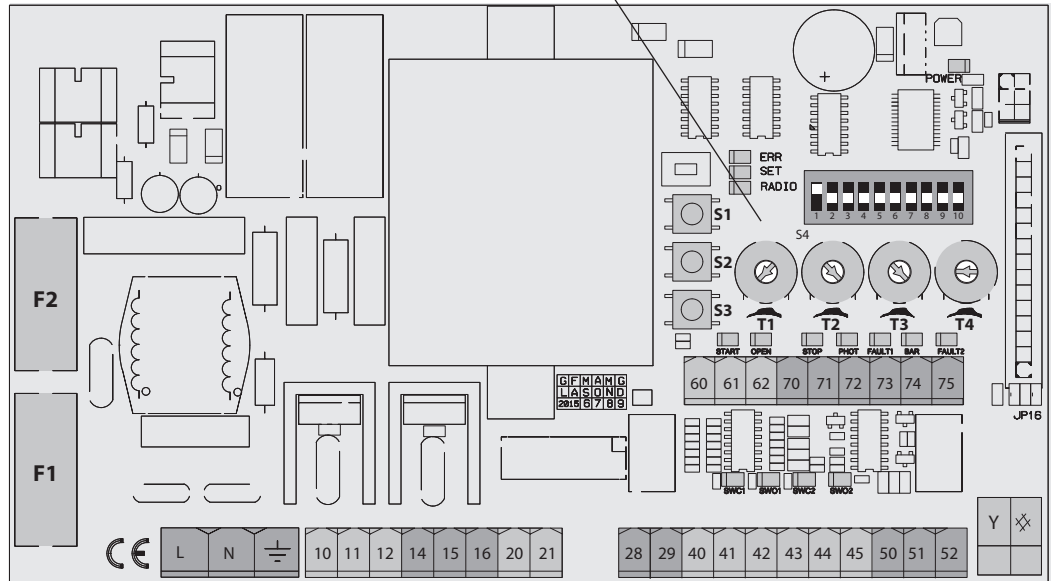
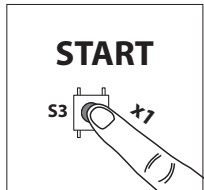

- F1** 3.15 AF (~230V)
6.3 AF (~120V)
- F2** 100mAT(~230V)
200mAT(~120V)

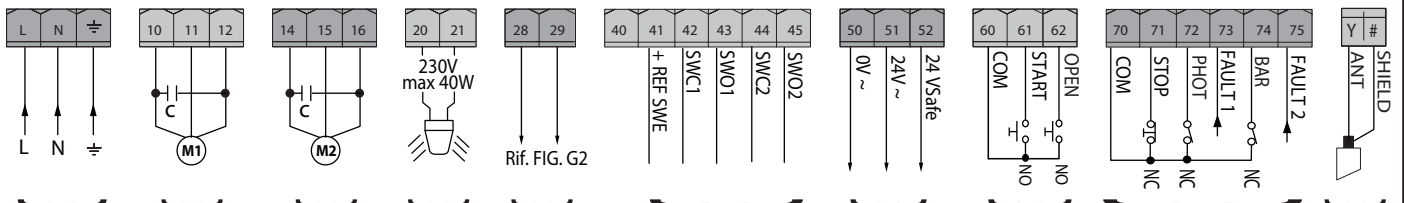

- | | | | | | | | | | |
|---|--|--|---|---|--|--|--|---|--|
| Alimentazione
Power supply
Alimentation
Stromversorgung
Alimentación
Voeding | Motore
Motor
moteur
Motor
Eindaanslag
Encoder | Motore
Motor
moteur
Motor
Eindaanslag
Encoder | Lampeggiante
Blinker
Clignotant
Warnblinkleuchte
Bombilla
Knipperlicht | Elettroserratura
Solenoid lock
Serrure électrique
Elektroschloss
Cerradura eléctrica
Elektrisch slot | Connettore finecorsa
Limit switch connector
Connecteur de fin de course
Steckverbindung Endschalter
Conector final de carrera
Connector eindaanslag | Alimentazione accessori
Accessories power supply
Alimentation des accessoires
Stromversorgung Zubehör
Alimentación accesorios
Voeding accessoires | Comandi
Commands
Commandes
Bedienelemente
Mandos
Commando's | Sicurezze
Safety devices
Sécuritéés
Sicherheitsvorrichtungen
Dispositivos de seguridad
Veiligheden | Antenna
Antenne
Antenne
Antenne
Antenna
Antenne |
|---|--|--|---|---|--|--|--|---|--|

**COLLEGAMENTO DI 1 COPPIA DI FOTOCELLULE
NON VERIFICATE, PER FOTOCELLULE VERIFICATE
VEDERE PAGINE SEGUENTI.**

**CONNECTION OF 1 COUPLE OF UNTESTED
PHOTOCELLS, FOR TESTED PHOTOCELLS SEE THE
FOLLOWING PAGES.**

**CONNEXION D'UNE PAIRE DE PHOTOCELLULES
NON VÉRIFIÉES, POUR LES PHOTOCELLULES
VÉRIFIÉES CONSULTEZ LES PAGES SUIVANTES.**

**ANSCHLUSS VON EINEM PAAR NICHT
ÜBERPRÜFTER FOTOZELLEN, FÜR ÜBERPRÜFTE
FOTOZELLE SIEHE DIE FOLGENDEN SEITEN.**

**CONEXIÓN DE 1 PAR DE FOTOCÉLULAS
NO COMPROBADAS, PARA FOTOCÉLULAS
COMPROBADAS VÉANSE LAS SIGUIENTES
PÁGINAS.**

**AANSLUITING VAN 1 PAAR NIET-GEVERIFIEERDE
FOTOCELLEN. RAADPLEEG DE VOLGENDE
PAGINA'S VOOR GEVERIFIEERDE FOTOCELLEN.**

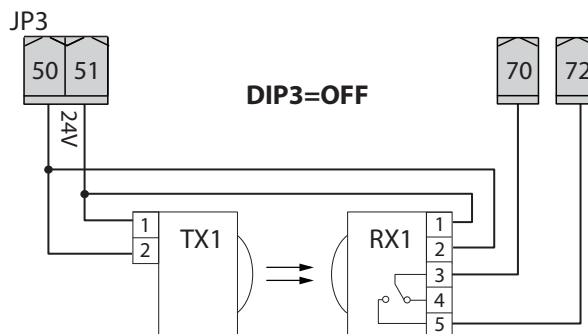

**MEMORIZZAZIONE RADIOCOMANDO
MEMORIZING REMOTE CONTROLS
MÉMORISATION RADIOCOMMANDE
ABSPEICHERUNG DER FERNBEDIENUNG
MEMORIZACIÓN DEL RADIOMANDO
MEMORIZAÇÃO DO RADIOCOMANDO**

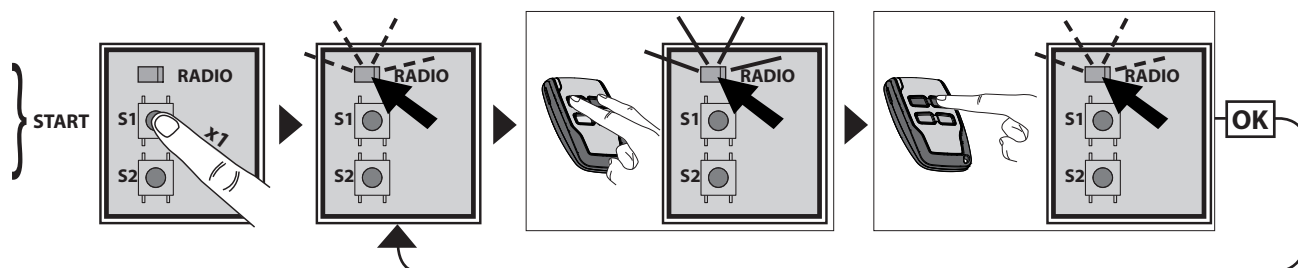

LEGENDA - KEY - LÉGENDE - LEGENDE - LEYENDA - LEGENDA



Fisso
Steadily lit
Fixe
Ununterbrochen an
Fijo
Continu



Lampeggio continuo
Continuous flashing
Clignotement continu
Kontinuierliches Blinken
Parpadeo continuo
Continu knipperen



Lampeggio intermittente
Intermittent flashing
Clignotement intermittent
intermittierendes Blinken
Parpadeo intermitente
Met intervallen knipperen

AUTOSET PER MOTORI CON FINECORSA
AUTOSET FOR MOTORS WITH LIMIT SWITCHES
AUTOCONFIGURATION POUR MOTEURS AVEC FIN DE COURSE
AUTOSET FÜR MOTOREN MIT ENDSCHALTER
AUTOSET PARA MOTORES CON FINAL DE CARRERA
AUTOSET VOOR MOTOREN MET EINDAANSLAGEN

D1

D812801 00100_01

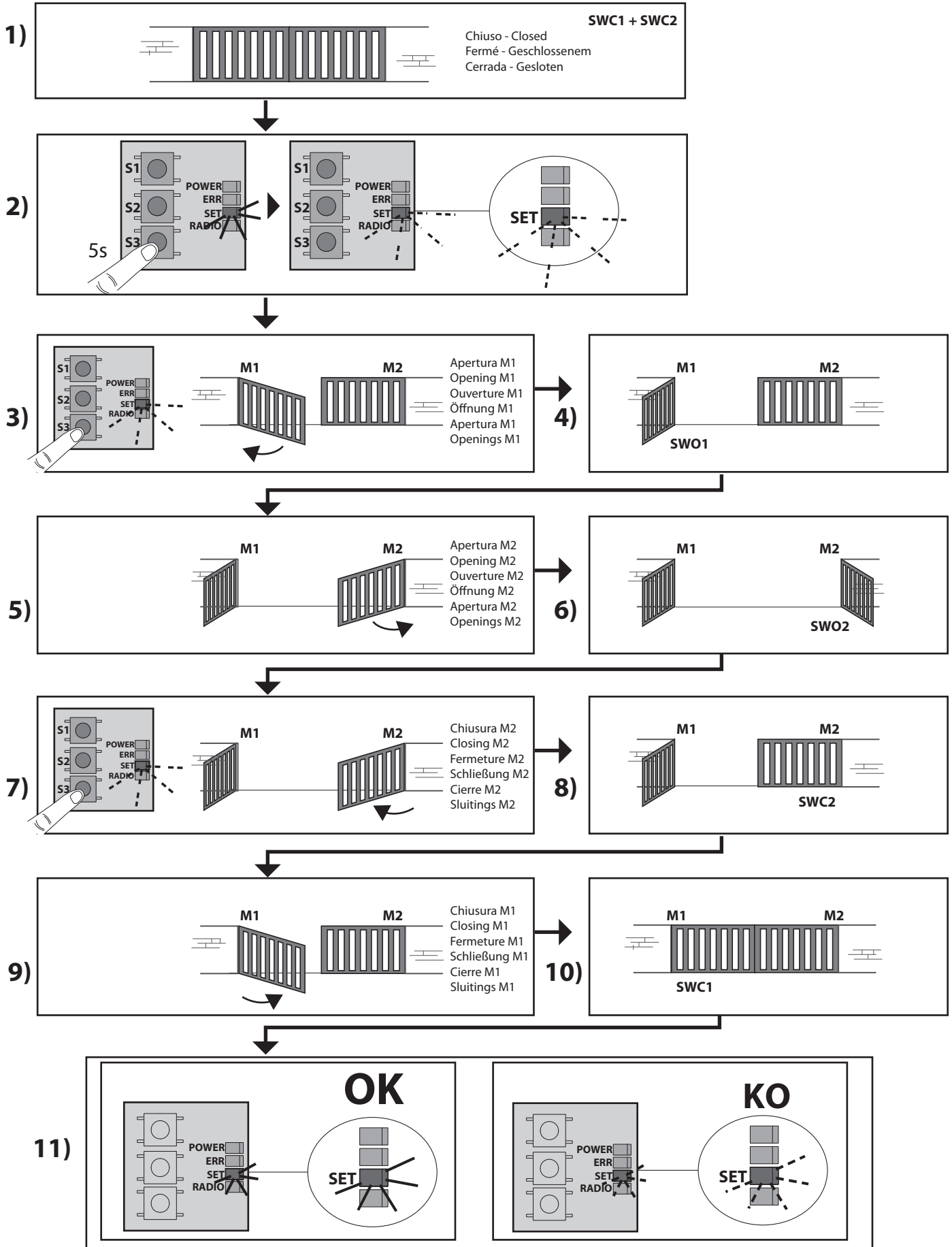

AUTOSET PER MOTORI SPROVVISTI DI FINECORSVA
AUTOSET FOR MOTORS WITH NO LIMIT SWITCHES
AUTOCONFIGURATION POUR MOTEURS SANS FIN DE COURSE
AUTOSET FÜR MOTOREN OHNE ENDSCHALTER
AUTOSET PARA MOTORES SIN FINAL DE CARRERA
AUTOSET VOOR MOTOREN ZONDER EINDAANSLAGEN

D2

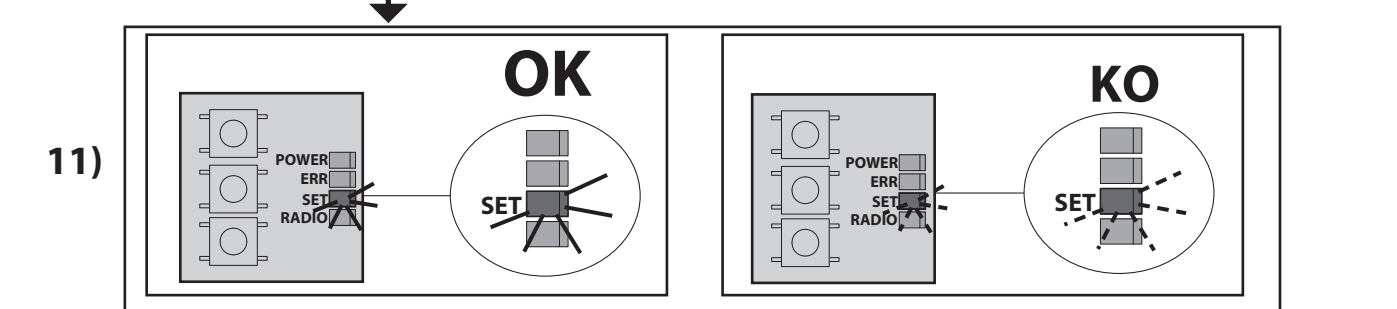
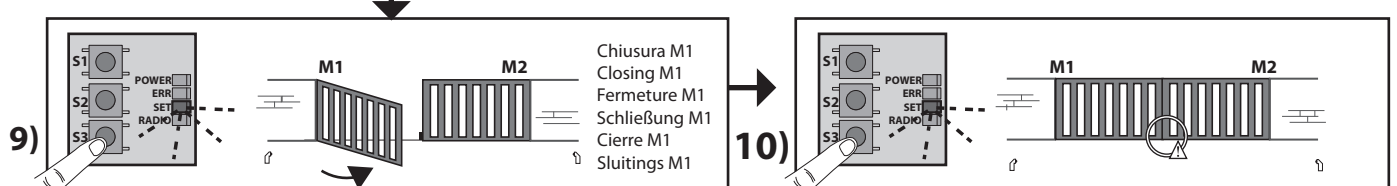
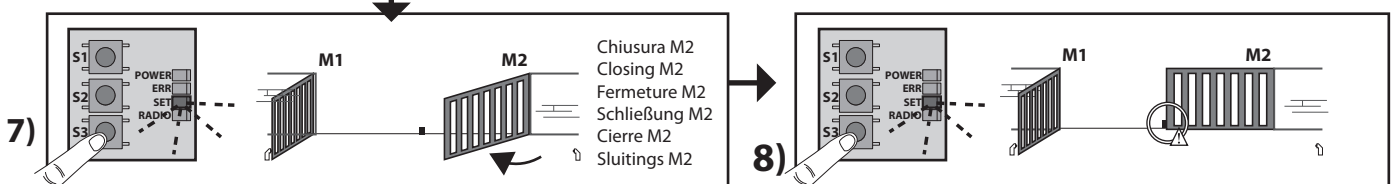
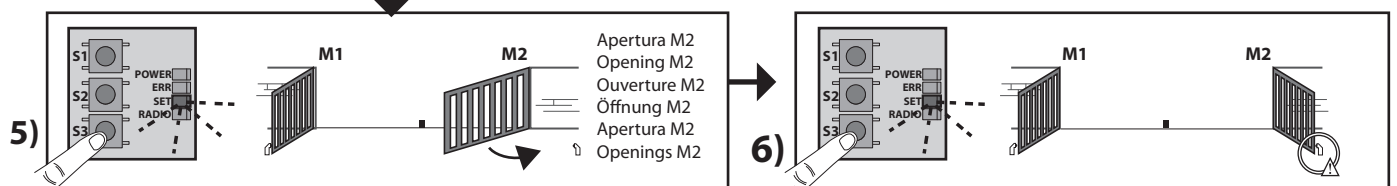
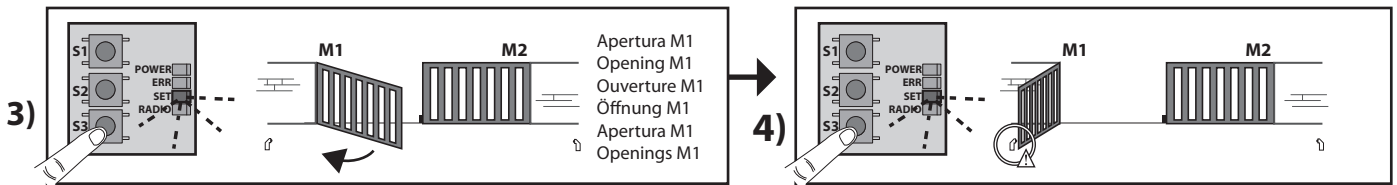
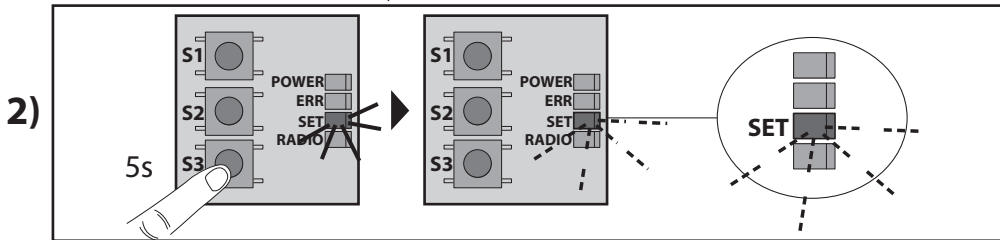
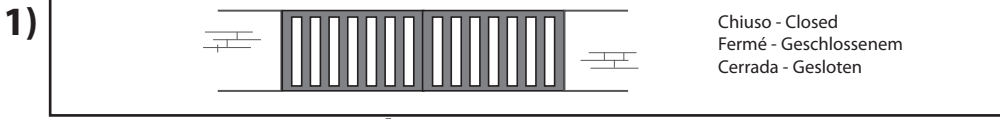

ITALIANO

ENGLISH

FRANÇAIS

DEUTSCH

ESPAÑOL

NEDERLANDS

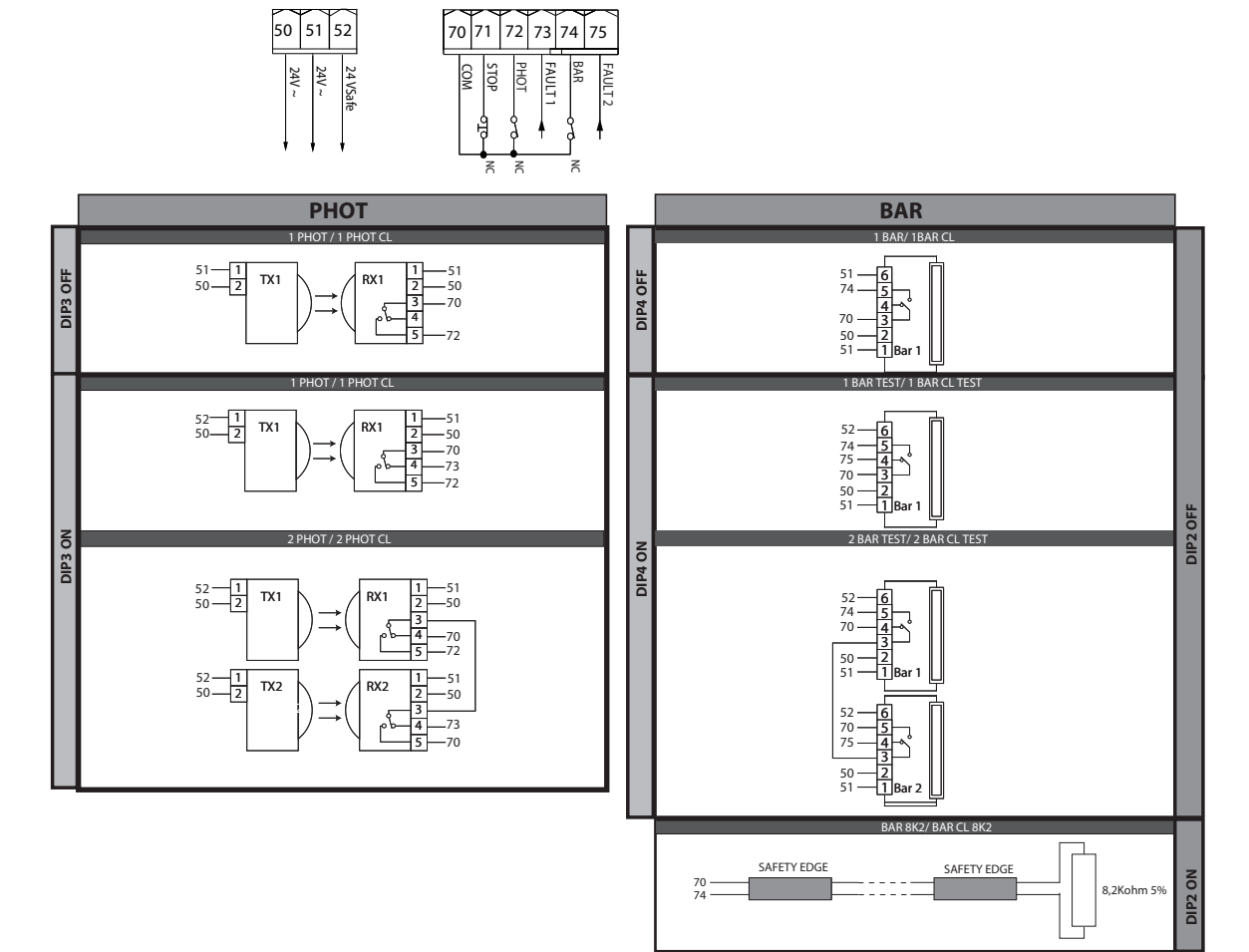
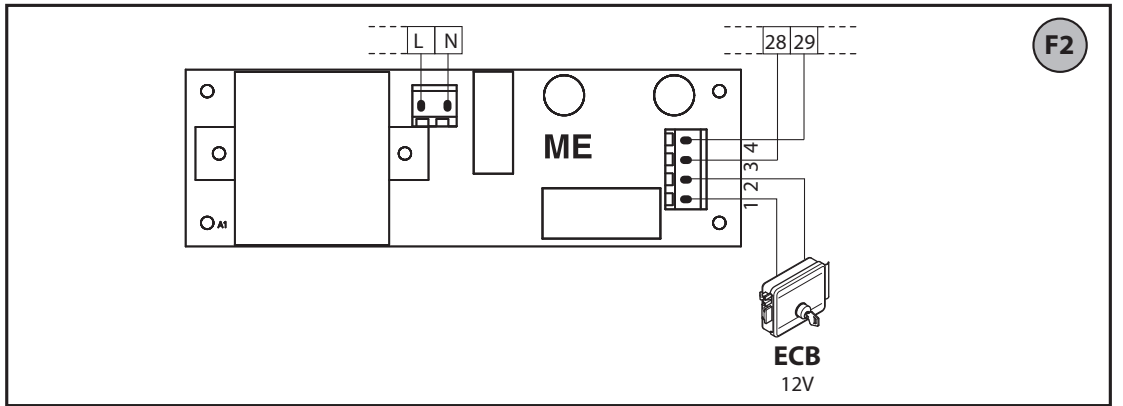
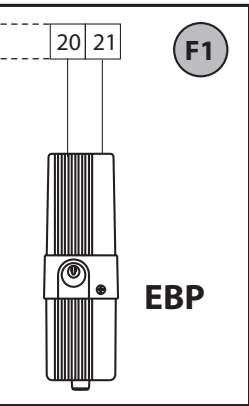
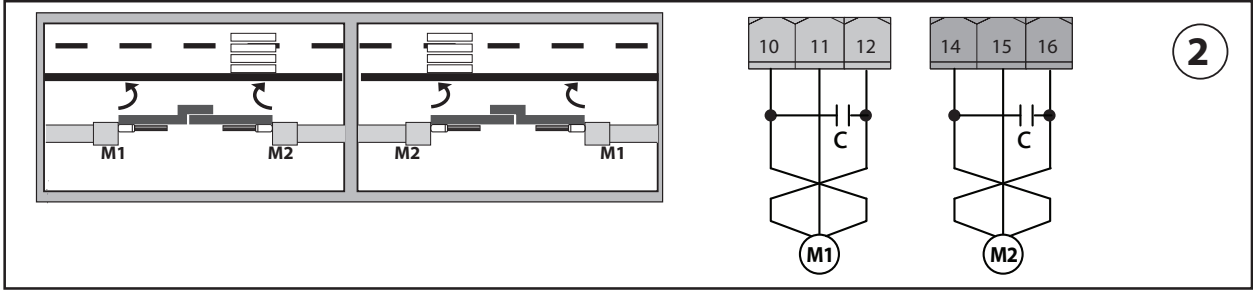
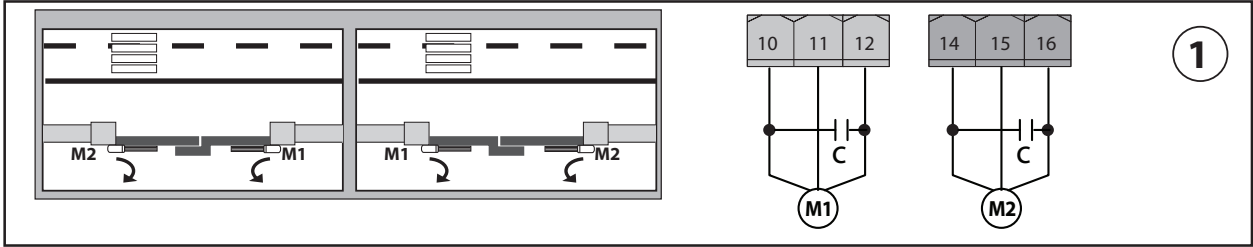

INSTALLATION MANUAL

1) GENERAL INFORMATION

The **ALENA SW2 CPEM** control panel comes with standard factory settings. Any change must be set by means of the TRIMMER and DIP SWITCH settings.

Its main features are:

- Control of 1 or 2 motors single-phase
- Note: 2 motors of the same type must be used.
- Electronic torque control
- Slowdown while opening and closing
- Separate inputs for safety devices
- Built-in radio receiver rolling code with transmitter cloning.

The board has a terminal strip of the removable kind to make maintenance or replacement easier. It comes with a series of prewired jumpers to make the installer's job on site easier.

The jumpers concern terminals: 70-71, 70-72, 70-74, 41-42, 41-43, 41-44, 41-45. If the above-mentioned terminals are being used, remove the relevant jumpers.

TESTING

The **ALENA SW2 CPEM** panel controls (checks) the start relays and safety devices (photocells) before performing each opening and closing cycle.

If there is a malfunction, make sure that the connected devices are working properly and check the wiring.

Operating temperature range	-20 / +55°C
Dielectric rigidity	mains/LV 3750V~ for 1 minute
Maximum motor power	400W+400W
Accessories power supply	24V ~ (demand max. 0,2A)
Solenoid lock	see Fig. F1-F2
AUX 0 - Flashing Contact powered	120V~ 40W max 230V~ 40W max
Fuses	see Fig. B
Built-in Rolling-Code radio-receiver	frequency 433.92MHz
Setting of parameters and logics	TRIMMER + DIP SWITCH
N° of combinations	4 billion
Max.n° of transmitters that can be memorized	63
Pedestrian work time	8 s.
Maximum work time	120s

Usable transmitter versions:

All ROLLING CODE transmitters compatible with ((CR-Ready))

2) TECHNICAL SPECIFICATIONS

Power supply *	110-120V 60Hz 220-230V 50/60 Hz
Low voltage/mains insulation	> 2MΩ 500V ---

	Terminal	Definition	Description			
Power supply	L	LINE	Single-phase power supply with earth cable			
	N	NEUTRAL				
	GND	EARTH				
Motor	10	START + CONDENSER	Motor and condenser connection. Time lag during closing. (Can be adjusted with trimmer T4)			
	11	COM				
	12	START + CONDENSER				
	14	START + CONDENSER	Motor and condenser connection. Time lag during opening. 2s			
	15	COM				
	16	START + CONDENSER				
Aux	20	AUX 0 – 230V POWERED CONTACT (N.O.) (40W MAX)	Exit due to FLASHING LIGHT. Contact stays closed while leaves are operating.			
	21					
	28	Solenoid lock	see Fig. F1-F2			
	29					
Limit switches	40	Not used				
	41	+REF SWE	Limit switch common			
	42	SWC1	Motor 1 closing limit switch SWC1 (N.C.).			
	43	SWO1	Motor 1 opening limit switch SWO1 (N.C.).			
	44	SWC2	Motor 2 closing limit switch SWC2 (N.C.).			
Accessories power supply	50	0V ~	Accessories power supply output.			
	51	24V ~				
	52	24 Vsafe ~		Tested safety device power supply output (photocell transmitter and safety edge transmitter). Output active only during operating cycle.		
Commands	60	Common	START and OPEN inputs common			
	61	START	START command button (N.O.). Operation according to "3/4-STEP" logic			
	62	OPEN	OPEN command button (N.O.). Gate opened with this command. If the input stays closed, the leaves stay open until the contact is opened. When the contact is open, the automated device closes following the TCA time, where activated.			
Safety devices	70	Common	STOP, PHOT and BAR inputs common			
	71	STOP	The command stops movement. (N.C.) If not used, leave jumper inserted.			
	72	PHOT (*)	PHOTOCELL input (N.C.). Operation according to "PHOTOCELL/PHOTOCELL DURING CLOSING" logic. If not used, leave jumper inserted.			
	73	FAULT 1	Test input for safety devices connected to PHOT.			
	74	BAR / BAR CL / BAR TEST / BAR CL TEST / BAR 8K2 / BAR CL 8K2 (*)	Safety edge input (N.C.). If not used, leave jumper inserted			
			BAR/8K2 dip	Safety edge check dip	Safety edge operation dip	
			OFF	OFF	OFF	NC input, no verification, reversal while opening and closing (BAR)
			OFF	OFF	ON	NC input, no verification, reversal only when closing, stop when opening (BAR CL)
			OFF	ON	OFF	NC input, with verification, reversal while opening and closing (BAR TEST)
			OFF	ON	ON	NC input, with verification, reversal only when closing, stop when opening (BAR CL TEST)
			ON	OFF	OFF	8K2 input, reversal while opening and closing (BAR 8K2)
			ON	OFF	ON	8K2 input, reversal only when closing, stop when opening (BAR CL 8K2)
	ON	ON	OFF	---		
ON	ON	ON	---			
75	FAULT 2	Test input for safety devices connected to BAR.				
Antenna	Y	ANTENNA	Antenna input. Use an antenna tuned to 433MHz. Use RG58 coax cable to connect the Antenna and Receiver. Metal bodies close to the antenna can interfere with radio reception. If the transmitter's range is limited, move the antenna to a more suitable position.			
	#	SHIELD				

(*) If "D" type devices are installed (as defined by EN12453), connect in unverified mode, foresee mandatory maintenance at least every six months.

(*) In the European Union, apply standard EN 12453 for force limitations, and standard EN 12445 for measuring method.

3) TUBE ARRANGEMENT Fig. A

Install the electrical system referring to the standards in force for electrical systems CEI 64-8, IEC 364, harmonization document HD 384 and other national standards.

4) TERMINAL BOARD WIRING Fig. B

WARNINGS - When performing wiring and installation, refer to the standards in force and, whatever the case, apply good practice principles. Wires carrying different voltages must be kept physically separate from each other, or they must be suitably insulated with at least 1mm of additional insulation. Wires must be secured with additional fastening near the terminals, using devices such as cable clamps.

All connecting cables must be kept far enough away from the dissipater.

WARNING! For connection to the mains power supply, use a multicore cable with a cross-sectional area of at least 3x1.5mm² of the kind provided for by the regulations in force. To connect the motors, use a cable with a cross-sectional area of at least 1.5mm² of the kind provided for by the regulations in force. The cable must be type H05RN-F at least.

5) SAFETY DEVICES

Note: only use receiving safety devices with free changeover contact.

5.1) TESTED DEVICES Fig. G

5.2) CONNECTION OF 1 PAIR OF NON-TESTED PHOTOCELLS Fig. C



WARNING!

The values of the impact force according to EN 12453 are only observed with the use of safety edges (active) connected to the board.

6) ADJUSTMENT PROCEDURE

- Before turning the unit on, check electrical connections.
- Adjust the mechanical limit switches (if any)
- Carry out an Autosest to set work time.
- Set the trimmers.
- Set the dip-switches.

WARNING! Incorrect settings can result in damage to property and injury to people and animals.

7) MEMORIZING TRANSMITTERS FIG. D RADIO

IMPORTANT NOTE: THE FIRST TRANSMITTER MEMORIZED MUST BE IDENTIFIED BY ATTACHING THE KEY LABEL (MASTER).

In the event of manual programming, the first transmitter assigns the RECEIVER'S KEY CODE: this code is required to subsequently clone the radio transmitters. The Clonix built-in on-board receiver also has a number of important advanced features:

- Cloning of master transmitter (rolling code or fixed code).
- Cloning to replace transmitters already entered in receiver.

To use these advanced features, refer to the universal handheld programmer's instructions and to the general receiver programming guide.

8) ADJUSTING THE AUTOSET

It allows setting the motor work time automatically.

The work times required to carry out opening and closing of both motors are measured; the higher of the 2 measured times is stored and safety time is added to guarantee complete opening or closing also when the motor performance varies.

WARNING!! The autosest must be carried out only after checking that the leaf is moving accurately (opening/closing) and the mechanical stops and limit switches are positioned correctly.

WARNING! During the autosest, the activation of photocells or safety edges causes the autosest function to fail and be abandoned.

WARNING! The autosest manoeuvres are performed at operating, not slow-down speed.

Autosest for motors with limit switches (Fig. D1):

- 1 - Place the leaves at the closing limit switch.
- 2 - Press button S3 for 5 seconds: the SET LED flashes.
- 3 - Press button S3 to start the opening manoeuvre of motor 1.
- 4 - Wait for the opening limit switch to be triggered to finish motor 1's opening manoeuvre.
- 5 - Motor 2 starts opening automatically.
- 6 - Wait for the opening limit switch to be triggered to finish motor 2's opening manoeuvre.
- 7 - Press the S3 button to start motor 2's closing manoeuvre.
- 8 - Wait for the closing limit switch to be triggered to finish motor 2's closing manoeuvre.
- 9 - Motor 1 starts closing automatically.
- 10 - Wait for the closing limit switch to be triggered to finish motor 1's closing manoeuvre.
- 11 - If the work time has been stored correctly, the SET LED comes on for 10 seconds.

If autosest fails the SET LED flashes quickly for 10 seconds.

If motor 1 is set to active, the phases relative to motor 2 are not performed.

Autosest for motors with no limit switches (Fig. D2):

- 1 - Place the leaves at the gate closure.
- 2 - Press button S3 for 5 seconds: the SET LED flashes.
- 3 - Press button S3 to start the opening manoeuvre of motor 1.
- 4 - Press the S3 button to finish motor 1's opening manoeuvre.
- 5 - Motor 2 starts opening automatically.
- 6 - Press the S3 button to finish motor 2's opening manoeuvre.
- 7 - Press the S3 button to start motor 2's closing manoeuvre.
- 8 - Press the S3 button to finish motor 2's closing manoeuvre.
- 9 - Motor 1 starts closing automatically.
- 10 - Press the S3 button to finish motor 1's closing manoeuvre.
- 11 - If the work time has been stored correctly, the SET LED comes on for 10 seconds.

If autosest fails the SET LED flashes quickly for 10 seconds.

If motor 1 is set to active, the phases relative to motor 2 are not performed.

9) REVERSING THE OPENING DIRECTION (FIG.E)

10) SOLENOID LOCK (Fig. F1-F2)



WARNING: In the case of leaves longer than 3m, it is essential to install a solenoid lock.

KEYS

KEYS	Description
S1	Add Start Key associates the desired key with the Start command.
S2	Add Pedestrian Key associates the desired key with the pedestrian command.
S2 >5s	Confirms the changes made to parameter settings and operating
S1+S2 >10s	Erase List WARNING! Erases all memorized transmitters from the receiver's memory.
S3	Pressed BRIEFLY, it gives the START command.
	HELD DOWN (>5 sec.), it activates the AUTOSET function.
	Pressing and holding (>10s) takes the work time back to the default value

LED INDICATORS:

POWER	Steadily lit: - Mains power on - Board powered - Fuses intact
START	Lit: START input activated
OPEN	Lit: OPEN pedestrian input activated
STOP	Unlit: STOP input activated
PHOT	Unlit: PHOT photocell input activated
FAULT 1	PHOT input safety device test input diagnostics
BAR	Unlit: BAR safety edge input activated
FAULT 2	BAR input safety device test input diagnostics
SWC1	Lit: the limit switch closing of motor 1 is free
	Unlit: motor 1 closing limit switch input activated
	Flashing: end of the work time while closing
SWO1	Lit: the limit switch opening of motor 1 is free
	Unlit: motor 1 opening limit switch input activated
	Flashing: end of the work time while opening
SWC2	Lit: the limit switch closing of motor 2 is free
	Unlit: motor 2 closing limit switch input activated
	Flashing: end of the work time while closing
SWO2	Lit: the limit switch opening of motor 2 is free
	Unlit: motor 2 opening limit switch input activated
	Flashing: end of the work time while opening
ERR	Unlit: no error
	LIT: see error diagnostics table
RADIO (GREEN)	Unlit: remote programming not active
	Radio LED only flashing: Remote programming active, waiting for hidden key.
	Flashing in sync with Set LED: Transmitter deletion in progress
	Lit: remote programming active, waiting for desired key.
	Lit 1s: Radio receiver channel activated
SET	LIT: see error diagnostics table
	Flashing in sync with Radio LED: Transmitter deletion in progress



WARNING: Check that the force of impact measured at the points provided for by standard EN 12445 is lower than the value laid down by standard EN 12453.

For best results, it is advisable to run the autosest function with the motors idle (i.e. not overheated by a considerable number of consecutive operations)

12) INSTALLATION TEST PROCEDURE

1. Apply pressure-sensitive or electro-sensitive protective devices (such as a safety edge)
2. Run the AUTOSET cycle (*)
3. Check the impact forces: if they fall within the limits (**) skip to point 5 otherwise
4. Allow the drive to move only in "Deadman" mode
5. Make sure all devices designed to detect obstacles within the system's operating range are working properly

(*) Before running the autosest function, make sure you have performed all the assembly and make-safe operations correctly, as set out in the installation warnings in the drive's manual and have set the opening/closing strength, slow-down and slow-down time parameters.



WARNING! Incorrect settings can result in damage to property and injury to people and animals.

ERROR TABLE:

		Led ERR		
		Lit	slow flashing	fast flashing
Led SET	Unlit		Photocell test, Costa o Costa 8k2 failed - Check photocell connection and/or logic settings	
	Lit	Reverse due to obstacle - Amperostop - Try turning the board off and back on or press button S2. If the problem persists, contact the technical assistance department.		Thermal cutout - Allow automated device to cool
	slow flashing	Internal system supervision control error. - Try switching the board off and back on again. - If the problem persists, contact the technical assistance department. - Thermal overload protection triggered on one of the 2 motors		Changed settings and/or Operating logics press S2 for 5s to confirm.

TABLE "A" - PARAMETERS

 Any modification of parameters/logics must be confirmed by pressing S2 > 5s

TRIMMER	Parameter			Description
		min.	max.	
T1	Automatic closing time [s]	0	120	Waiting time before automatic closing. NOTE: Set to 0 if not used.
T2	Leaf force [%]	1	100	Force exerted by leaf/leaves. ⚠ WARNING: It affects impact force directly: make sure that current safety requirements are met with the set value (*). To comply with the current safety regulations, install anti-crushing safety devices (**). Note: if this parameter is modified, a new Autoset must be carried out.
T3	Slowdown time [s]	0	30	Sets the slowdown time performed at the end of each opening and closing operation. 0 = Slowdown disabled NOTE: Do not use with hydraulic motors.
T4	Motor 1 closing delay time [s]	0	25	Motor 1 closing delay time with respect to motor 2. NOTE: set 0 for single motor operations (leaf 1).

(*) In the European Union, apply standard EN 12453 for force limitations, and standard EN 12445 for measuring method.

(**) Impact forces must be limited with the use of EN12978 compliant active safety edges

TABLE "B" - LOGICS

Any modification of parameters/logics must be confirmed by pressing S2 > 5s

DIP	Logic	Default	Cross out setting used	Description	
1	Transmitter programming	ON	ON	Enables wireless memorizing of transmitters: 1- Press in sequence the hidden key and normal key (T1-T2-T3-T4) of a transmitter that has already been memorized in standard mode via the radio menu. 2- Press within 10 sec. the hidden key and normal key (T1-T2-T3-T4) of a transmitter to be memorized. The receiver exits programming mode after 10 sec.: you can use this time to enter other new transmitters. This mode does not require access to the control panel. IMPORTANT: Enables the automatic addition of new transmitters, clones and replays.	
			OFF	Disables wireless memorizing of transmitters and automatic addition of clones. Transmitters are memorized only using the relevant Radio menu or automatically with replays. IMPORTANT: Disables the automatic addition of new transmitters and clones	
2	BAR / 8K2	OFF	ON	Input configured as Bar 8k2 (Fig.G). Input for resistive edge 8K2. The command reverses movement for 2 sec.	
			OFF	Input configured as Bar, safety edge (Fig.G). The command reverses movement for 2 sec..	
3	Photocell input check	OFF	ON	Enable safety check on the PHOT input. Fig.G	
			OFF	Safety check on PHOT input not enabled. Fig.G	
4	Edge input check	OFF	ON	Enable safety check on the BAR input. Fig.G	
			OFF	Safety check on BAR input not enabled. Fig.G	
5	Photocells during closing	OFF	ON	In the event beam is broken, photocell operation is disabled during opening. During closing, movement is reversed immediately.	
			OFF	When beam is broken, photocells are active during both opening and closing. When beam is broken during closing, movement is reversed only once the photocell is cleared.	
6	Safety edge input operation	OFF	ON	Safety edge with active reversal only when closing, when opening the movement stops	
			OFF	Safety edge with active reversal in both directions	
7	Fast closing	OFF	ON	Closes 3 seconds after the photocells are cleared before waiting for the set TCA to elapse.	
			OFF	Logic not enabled	
8	Residential / apartment building operation	OFF	ON	Sets the automation type of operation: ON = Apartment building	
			OFF	OFF = Residential	
			Reaction to the START input (wired or radio):		
				Residential	Apartment building
			CLOSED	Opens	Opens
			WHILE CLOSING	Stops	Opens
			OPEN	Closes	Closes
			WHILE OPENING	STOPS + TCA	No effect
			AFTER STOP	Opens	Opens
			Reaction to the OPEN input (wired):		
				Residential	Apartment building
			CLOSED	Opens	Opens
WHILE CLOSING	Opens	Opens			
OPEN	No effect	No effect			
WHILE OPENING	Keeps it open	Keeps it open			
AFTER STOP	Opens	Opens			
Reaction to the PEDESTRIAN input (radio):					
	Residential	Apartment building			
CLOSED	Opens partially	Opens partially			
WHILE CLOSING	Stops	Opens partially			
OPEN	Closes	Closes			
WHILE OPENING	STOPS + TCA	No effect			
AFTER STOP	Opens partially	Opens partially			
9	Hammer during opening	OFF	ON	Before opening completely, the gate pushes for approx. 2 seconds as it closes. This allows the solenoid lock to be released more easily. IMPORTANT - Do not use this function if suitable mechanical stops are not in place.	
			OFF	Logic not enabled	
10	Not used				

TORAUTOMATIC
Put Loparica 23
ZAGREB