



tuned to you

230v Hydraulic Rams QRG

(see also Rigel 5 QRG)

Quick reference guides are not a replacement for the supplied instructions, they are supplementary

Read and understand the installer warnings in the main instruction document first

Always apply good, safe, state of the art engineering and electrical installation principles

Safety of the completed installation is the ultimate responsibility of the installer

This product is not suitable for DIY use and should only be installed and maintained by a trained, skilled, professional installer



Geometry

All motors will work best when $A = B$, any other configuration will detract from its performance and could affect reliability

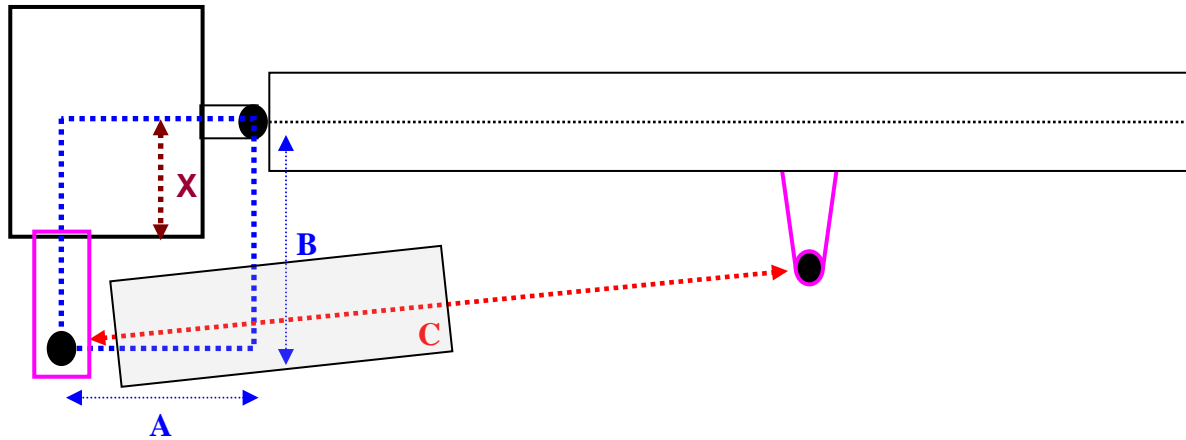

“B” MINUS “X” Must equal $>$ half the ram case width

This dimension is to ensure the operator does not contact the gate post

Geometry

Ram	A	B	C	B minus X
Oro	120	120	890	40
Lux, 2B, MB & L	135	135	985	45
Lux 2B FC	140	140	See next slide	45
Lux G & GVS	195	195	1240	45
Lux 2B R	125	125	See next slide	45
P Series	195	195	See next slide	50

All rams need 10mm of travel left un used in the open and closed positions except the FC which is intended to stop at its closed end of travel

Lux 2B R, FC 2B & P Series

To achieve the designed features of these rams the C dimension needs to be set very accurately on the gate;

- Set any adjustable nose fitting at 50/50 in/out
- Set control panel “Not Torque” to 99%
- Support the motor horizontally
- Drive the motor fully out via the control panel

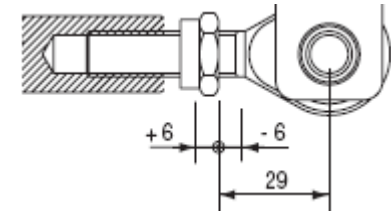

Lux R & P Series;

- Manual release and retract the piston 10mm
- Offer the ram to the gate in its closed position and attach the gate bracket

Lux FC 2B;

- Offer the ram to the gate in its closed position and attach the gate bracket with the ram at full extension

Length, Weight, Locks, Duty & Speed

Leaf weight/length should not be exceeded;

Oro (1B)	180kg/1.8m	60/24h	20sec
Lux, Lux (2B)	300Kg/2m	500/24h	17sec
Lux (MB)	300Kg/2.3m	500/24h	23sec
Lux R (2B)	300Kg/2m	500/24h	16sec
Lux FC (2B)	300Kg/2m	500/24h	17sec
Lux L	500Kg/2m or 300Kg/4m	350/24h	33sec
Lux GVS	300Kg/3.5m	500/24h	28sec
Lux G (2B)	800Kg/3m	250/24h	48sec
Lux G	800kg/3m or 300kg/5m	250/24h	48sec
P4.5/7	800Kg/4.5m & 7m	500/24h	28/42sec

Ground stops are required in the open and closed positions with the exception of the Lux FC 2B which only needs open stops.

Locking rams (xB) are not recommended for wind affected gates

Note; "B" = "Bloccare" – lock in Italian

Wiring

Rigel 5

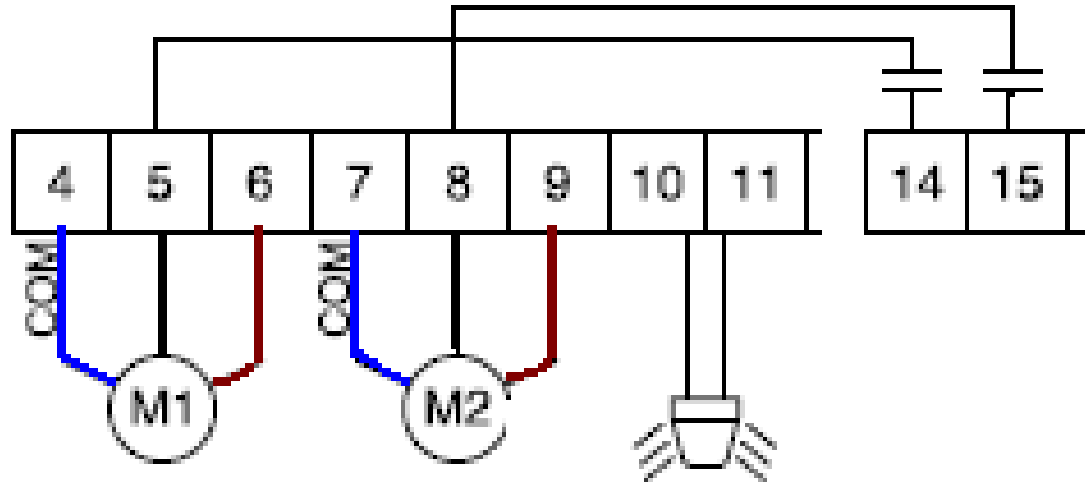

Use 3 core externally rated flex in accordance with BS7671
1.5mm² up to 20m

Method

Fit the motors and check the end of stroke limits

Set the gates half open/closed

Wire in the motors

Follow the quick menu (V2) or set Motor torque to 99% (older panels)

Short 30/31 rams should move in the open direction

Reverse the brown/black on any ram that moves in the close direction

Remove the vent screws

Adjust the pressure screws to give safe leaf force

Set run times via the traditional menu to actual +5 seconds

Fit accessories one at a time and test each before moving on

MD Compliance

Fit a 25mm ASO safe edge to the M2 leaf

Adjust close delay to give 700mm min. between M2 and M1 at closing

Test the force/time at 500mm in line with the motor

Adjust the close force screw to just below the 400Nm limit

Increase emergency brake if required

Also use hydraulic slow down Lux R and P series rams

(Over long leafs or poor geometry will have adverse affect on force test results)

Run a full set of tests

Address all other risks as appropriate