

8

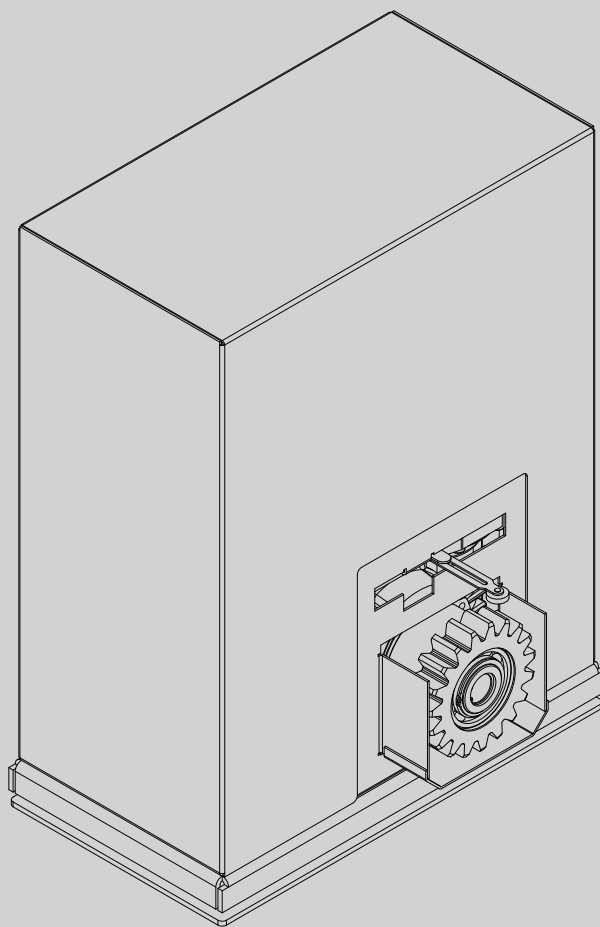

D811727 00100\_10 19-11-14

ATTUATORE PER CANCELLI SCORREVOLI A CREMAGLIERA  
 ACTUATOR FOR RACK SLIDING GATES  
 ACTIONNEUR POUR PORTAILS COULISSANTS Á CRÉMAILLÈRE  
 TRIEB FÜR SCHIEBETORE MIT ZAHNSTANGE  
 ACCIONADOR PARA CANCELAS CORREDERAS DE CREMALLERA  
 ACTUATOR VOOR SCHUIFHEKKEN MET TANDHEUGEL



ISTRUZIONI D'USO E DI INSTALLAZIONE  
 INSTALLATION AND USER'S MANUAL  
 INSTRUCTIONS D'UTILISATION ET D'INSTALLATION  
 INSTALLATIONS-UND GEBRAUCHSANLEITUNG  
 INSTRUCCIONES DE USO Y DE INSTALACION  
 INSTALLATIEVOORSCHRIFTEN

# SP 3500

# BFT



AZIENDA CON SISTEMA DI GESTIONE  
 INTEGRATO CERTIFICATO DA DNV  
 = UNI EN ISO 9001:2008 =  
 UNI EN ISO 14001:2004

**Attenzione!** Leggere attentamente le "Avvertenze" all'interno! **Caution!** Read "Warnings" inside carefully! **Attention!** Veuillez lire attentivement les Avertissements qui se trouvent à l'intérieur! **Achtung!** Bitte lesen Sie aufmerksam die „Hinweise“ im Inneren! **¡Atención!** Leer atentamente las "Advertencias" en el interior! **Let op!** Lees de "Waarschuwingen" aan de binnenkant zorgvuldig!

[www.torautomatic.hr](http://www.torautomatic.hr)

# INSTALLAZIONE VELOCE-QUICK INSTALLATION-INSTALLATION RAPIDE SCHNELLINSTALLATION-INSTALACIÓN RÁPIDA - SNELLE INSTALLATIE

D811727 00100\_10

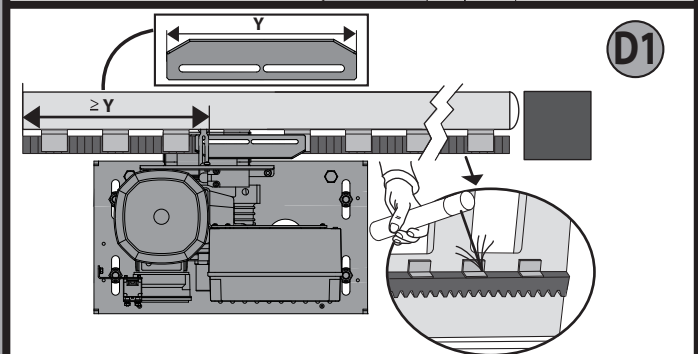
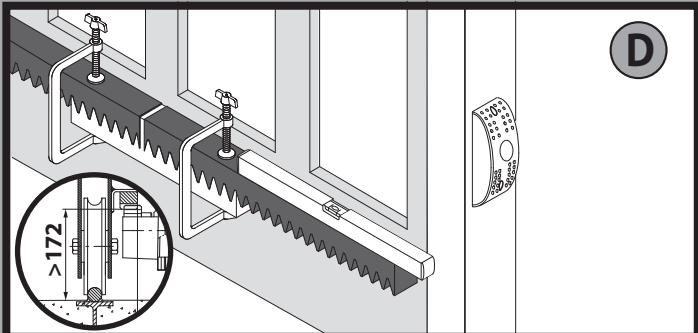
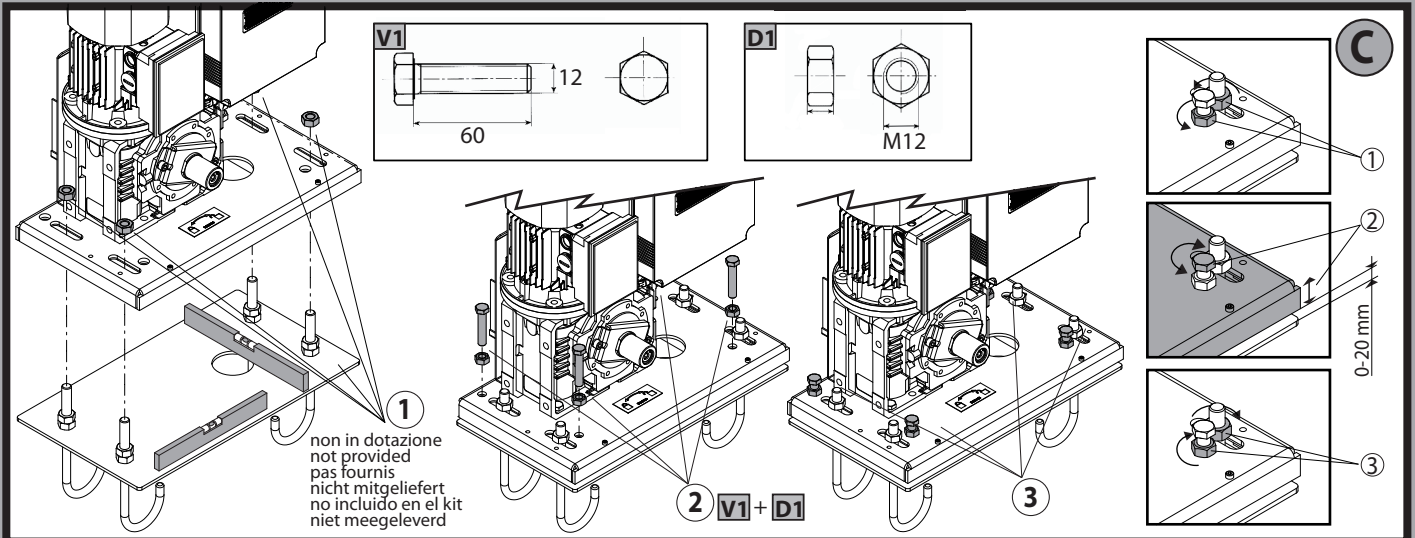
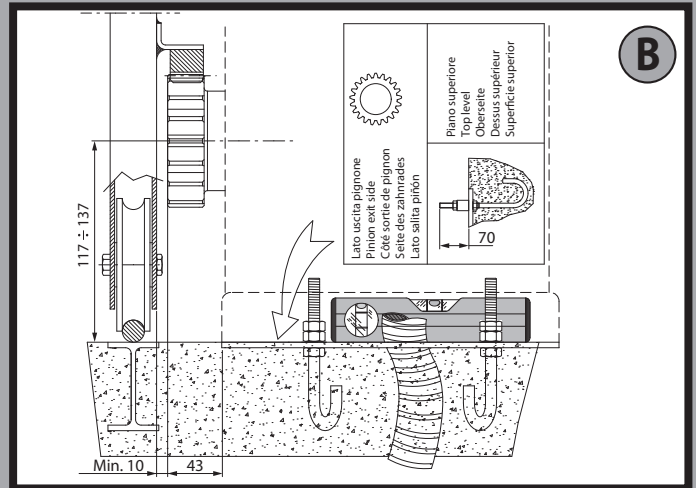
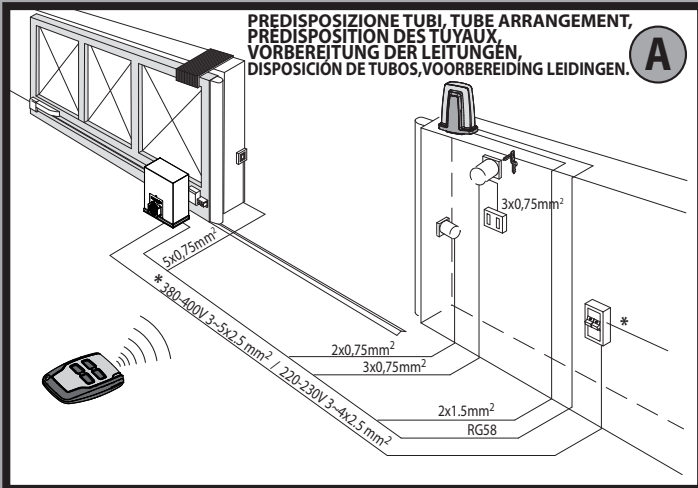

Montaggio accessori trasmissione, Mounting drive accessories,  
Montage accessoires transmission, Montage Antriebszubehör,  
Montaje de accesorios transmisión, Montage accessoires overbrenging.

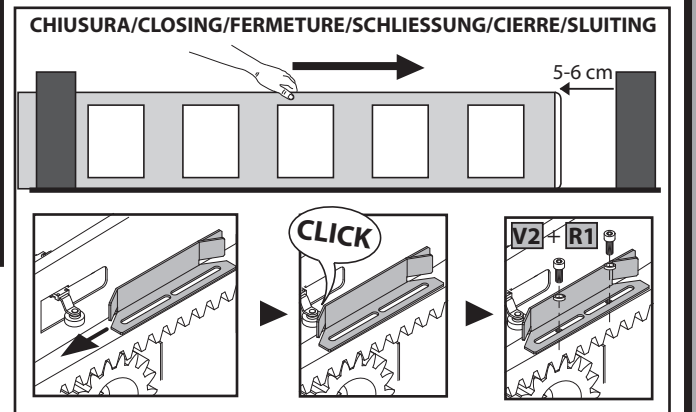
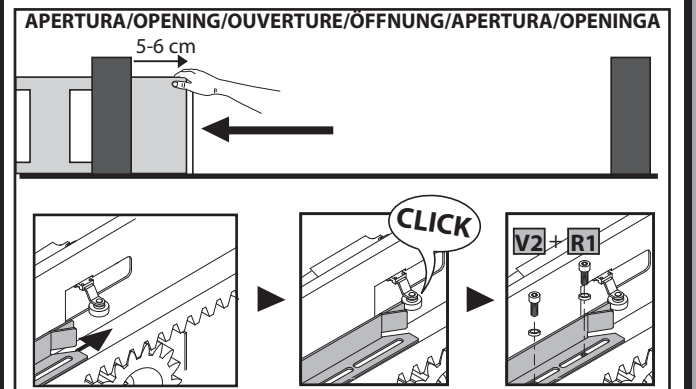
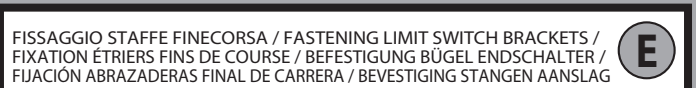
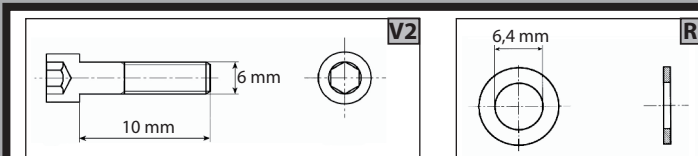

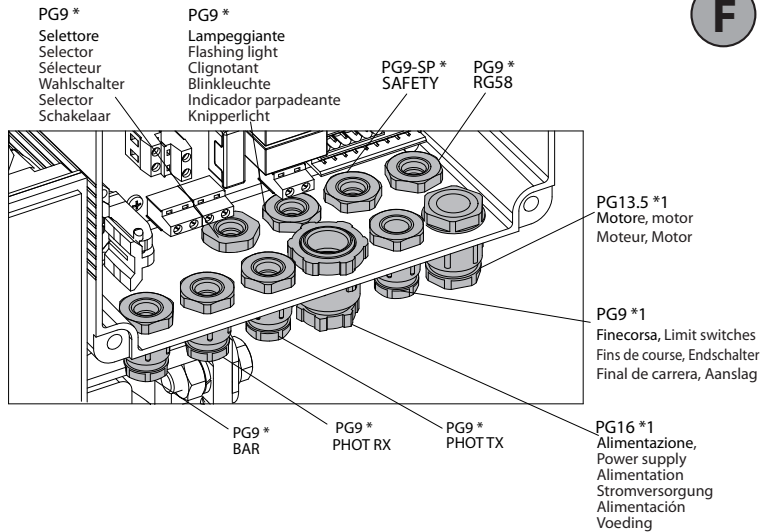
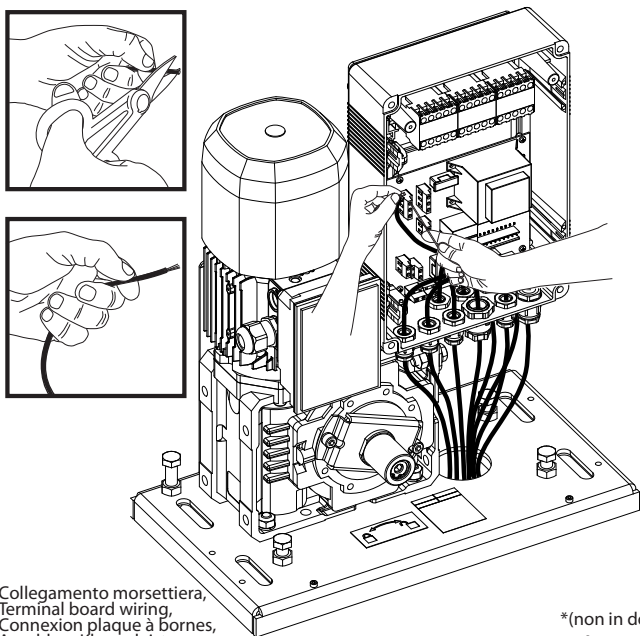

Collegamento morsettiere, Terminal board wiring, Connexion plaque à bornes, Anschluss Klemmleiste, Conexión tablero de bornes, Aansluiting aansluitkast.

\*(non in dotazione/not provided/pas fournis/nicht mitgeliefert/no incluido en el kit/niet meegeleverd)  
 \*(fornito/provided/fourni/mitgeliefert/incluido en el kit/geleverd)

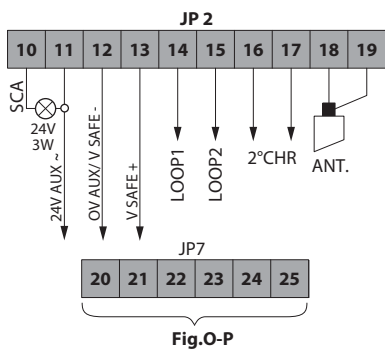
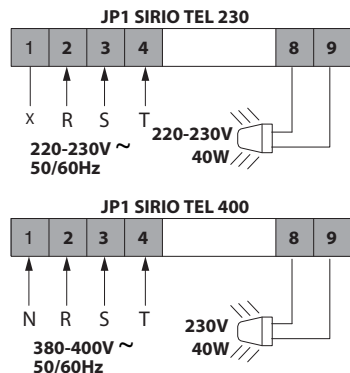
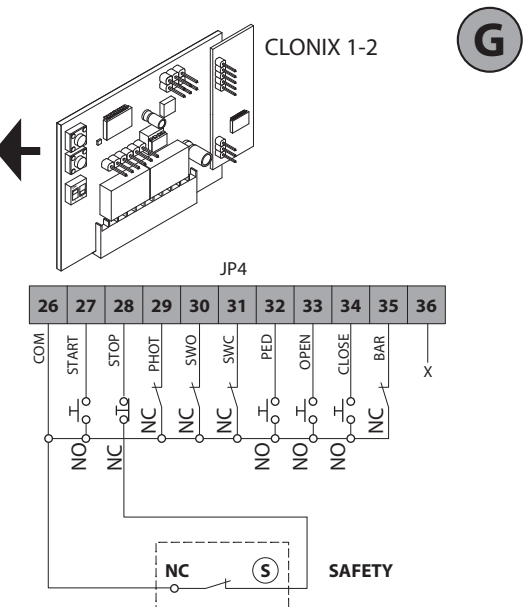
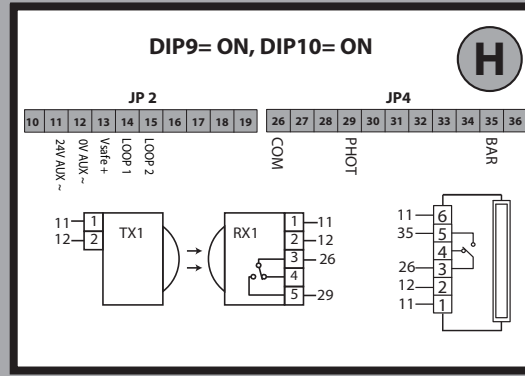
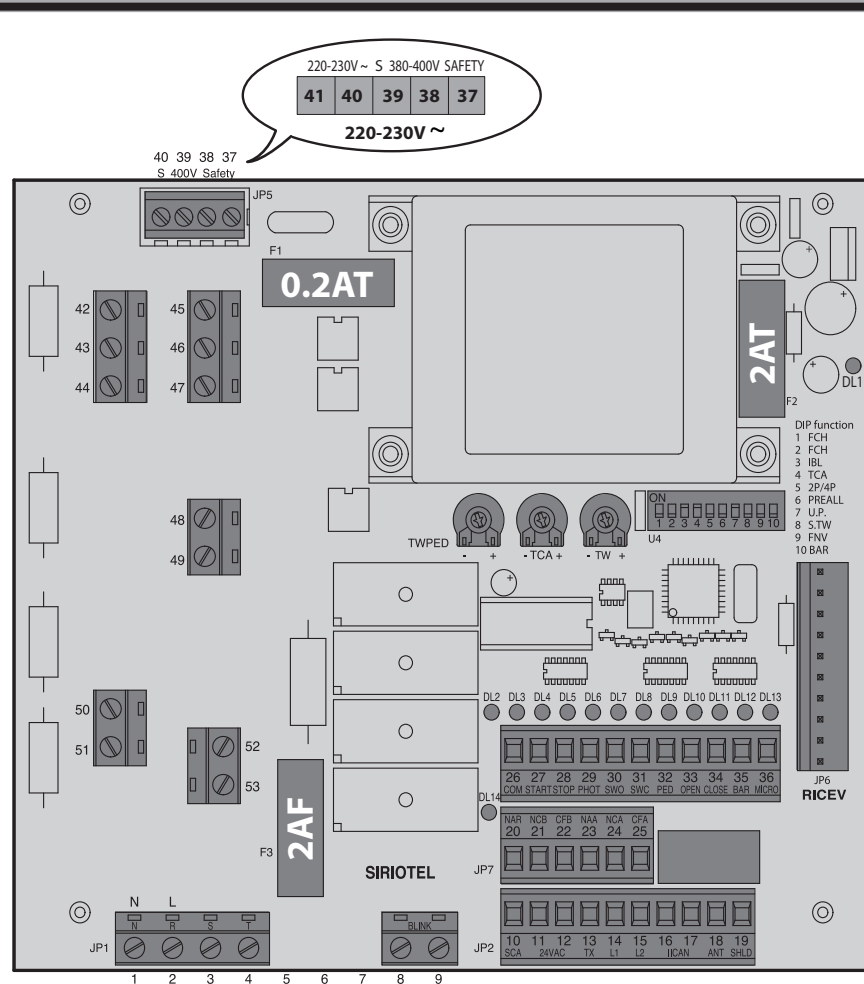

non in dotazione not provided pas fournis nicht mitgeliefert no incluido en el kit niet meegeleverd

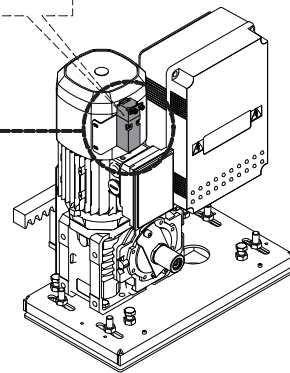

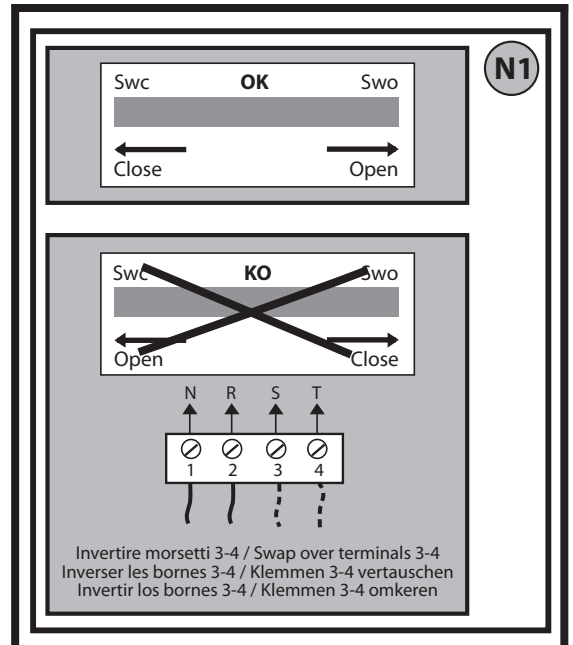
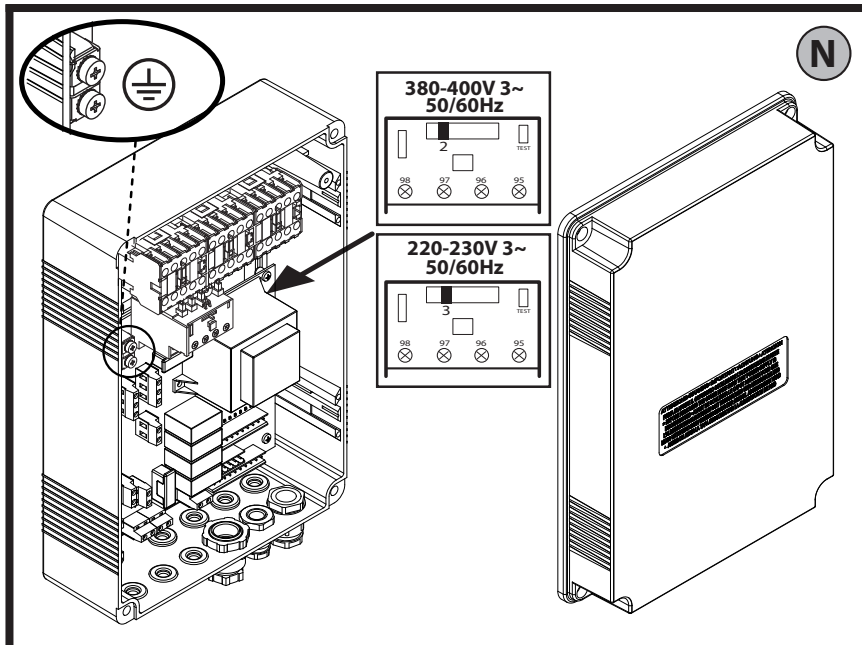
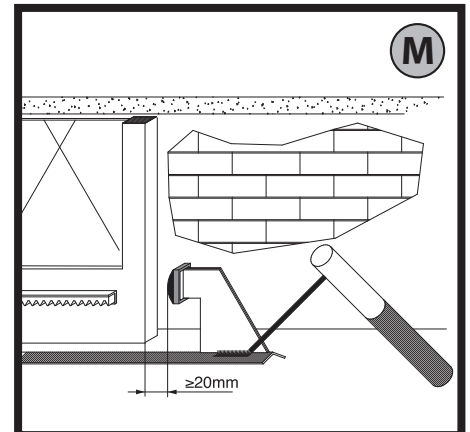
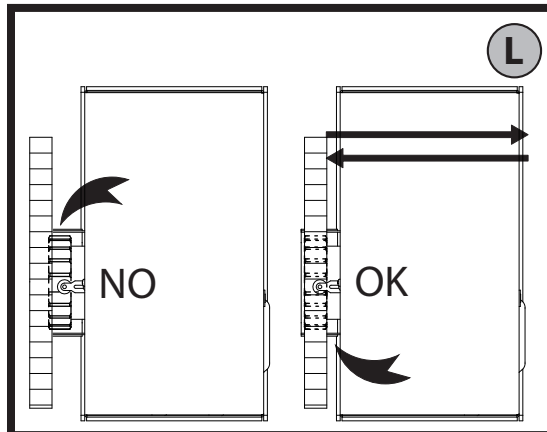
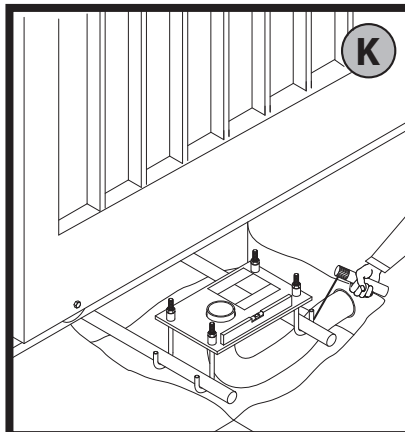
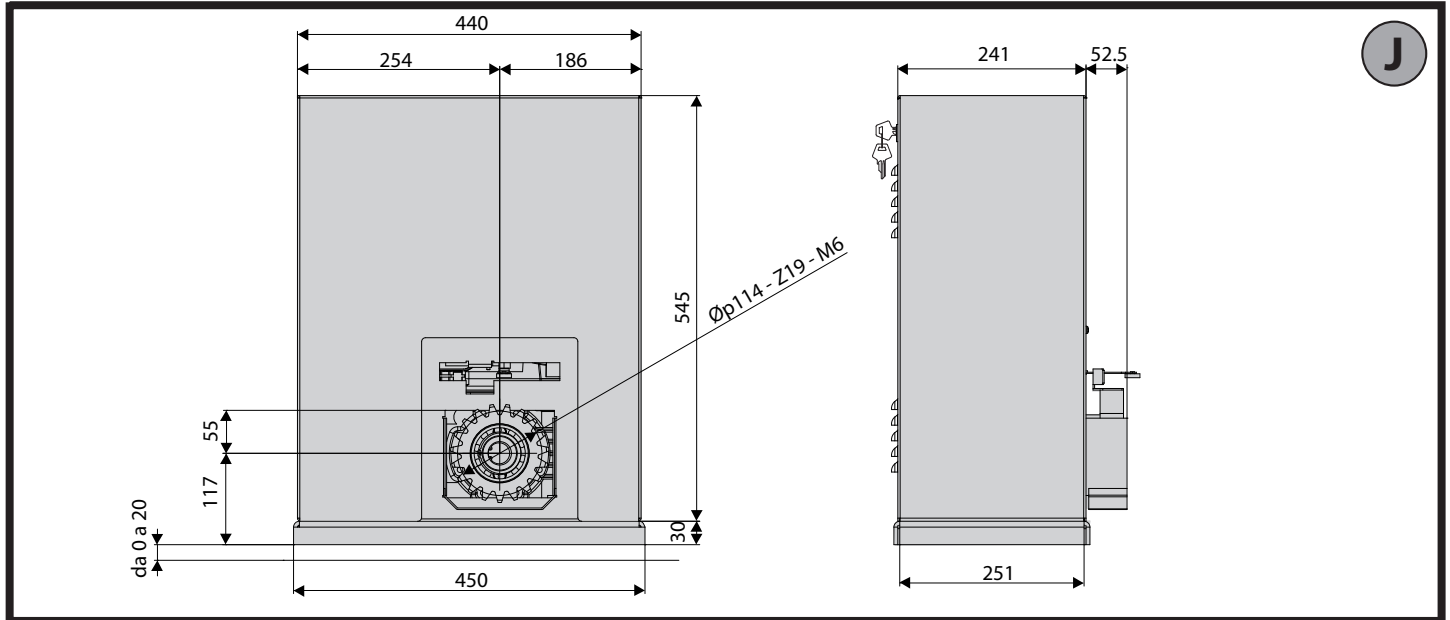
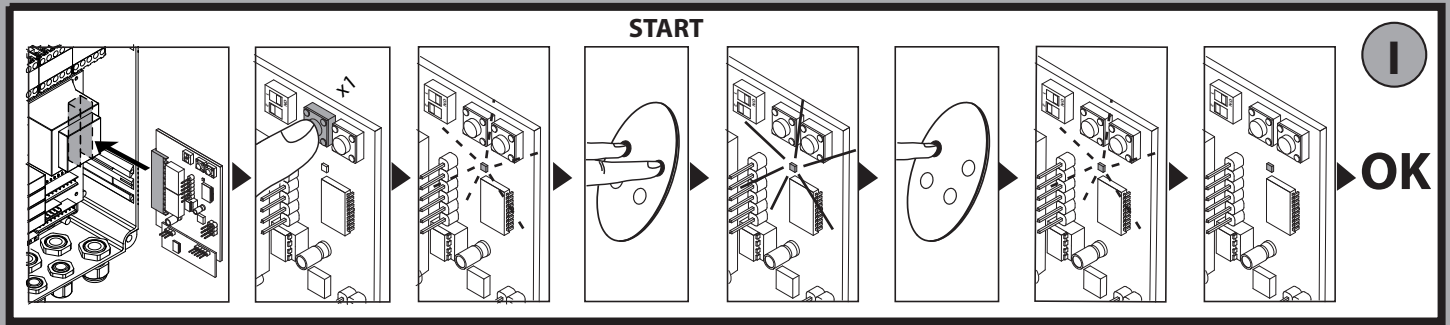

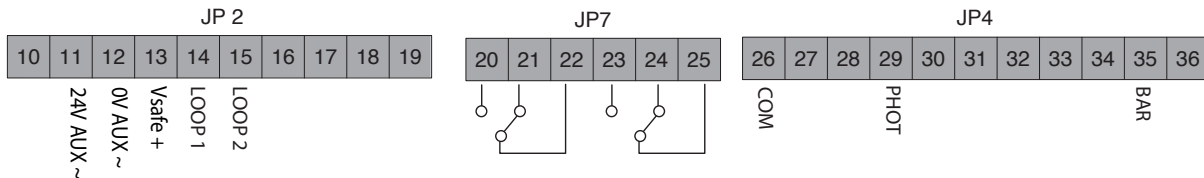

FOTOCELLE FOTOELEN      PHOTOCELLS FOTOCÉLULAS      PHOTOCEL FOTOCELLEN

1 PHOT

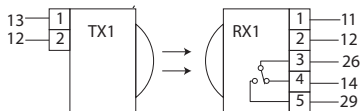

2 PHOT

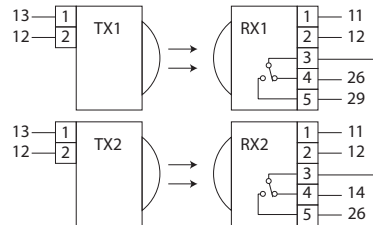

3 PHOT

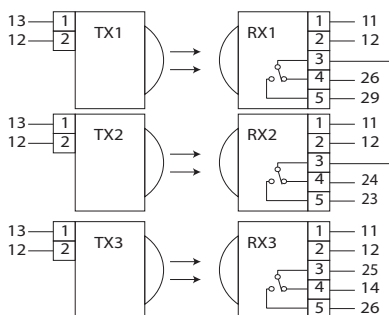

4 PHOT

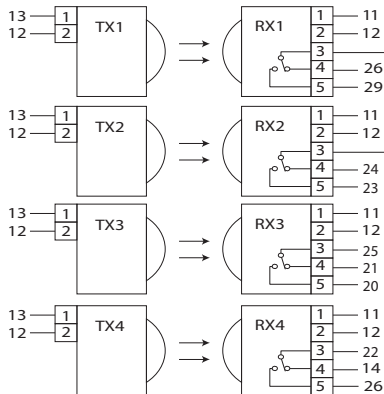

COSTE LEISTEN      SAFETY EDGES CANTOS      LINTEAUX RANDEN

1 BAR

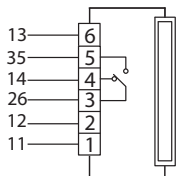

2 BAR

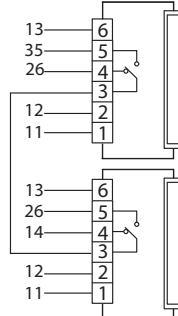

3 BAR

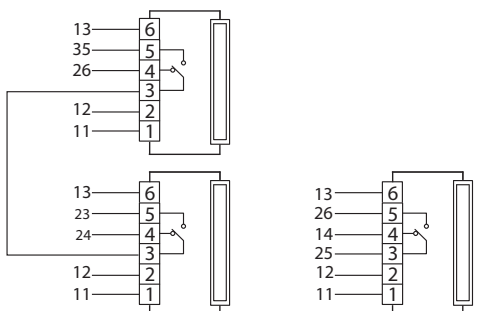

4 BAR

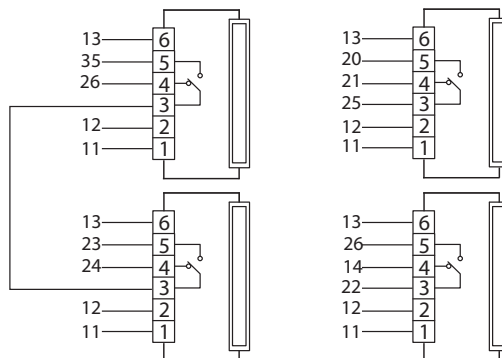

DIP 9 = OFF

DIP 10 = OFF

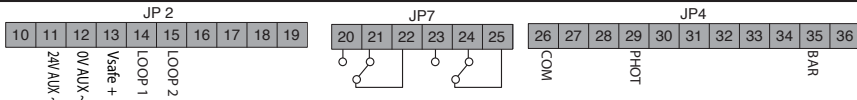

DIP9 = OFF, DIP 10 = OFF

DIP9 = OFF, DIP 10 = OFF

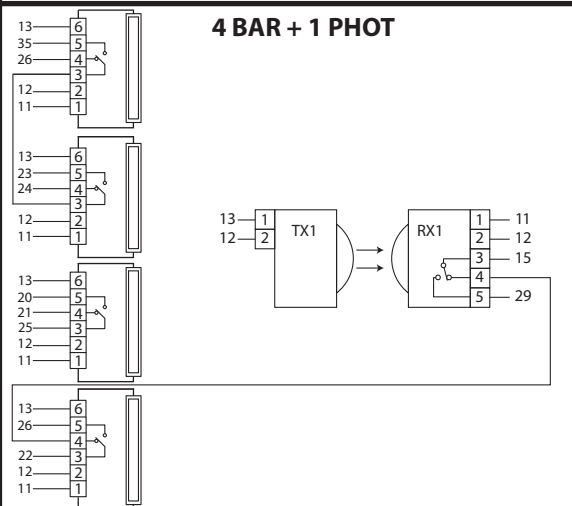
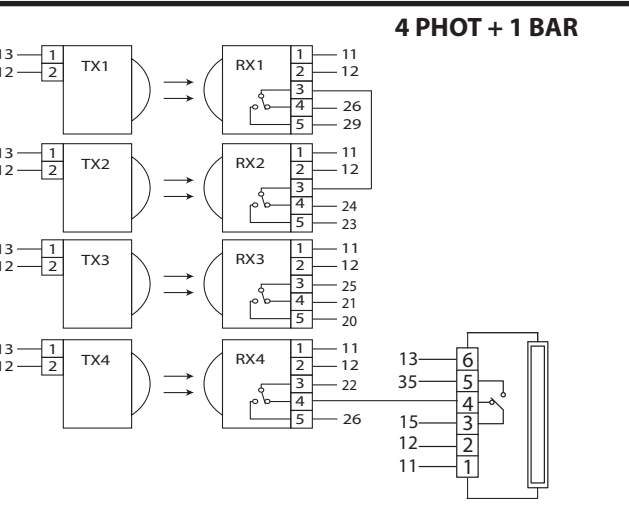
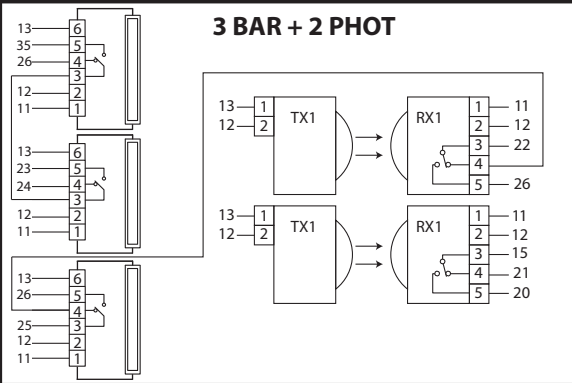
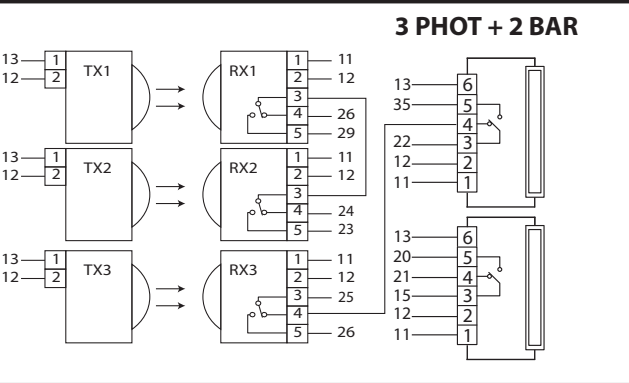
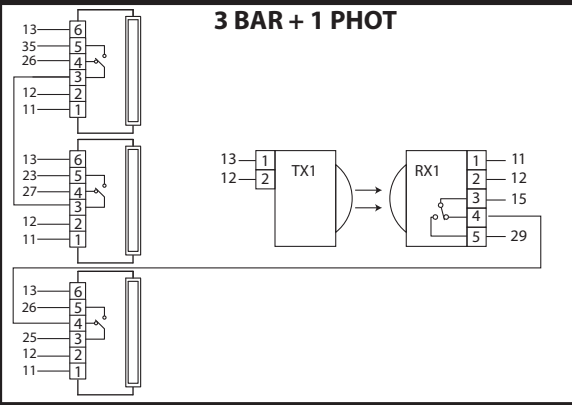
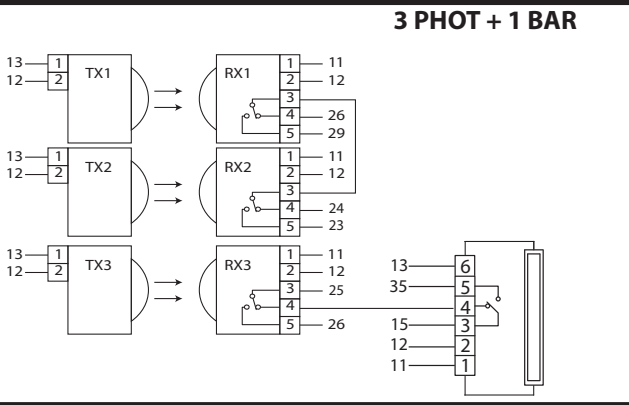
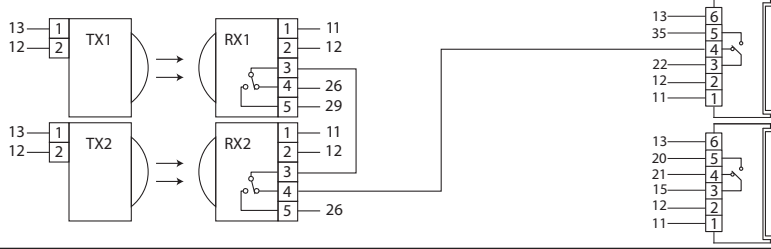
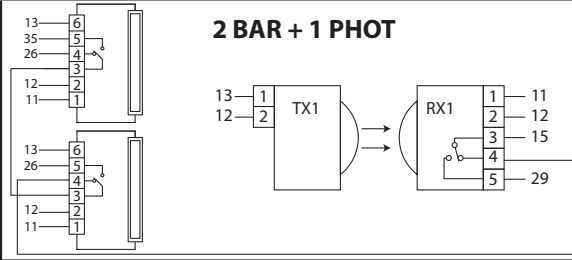
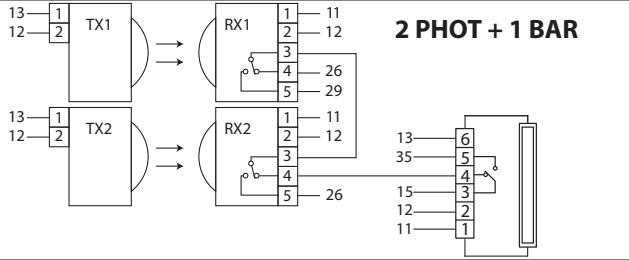
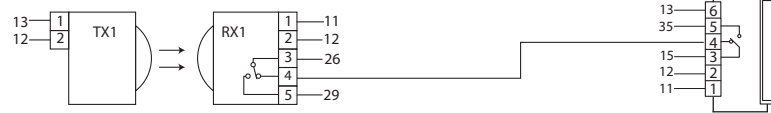

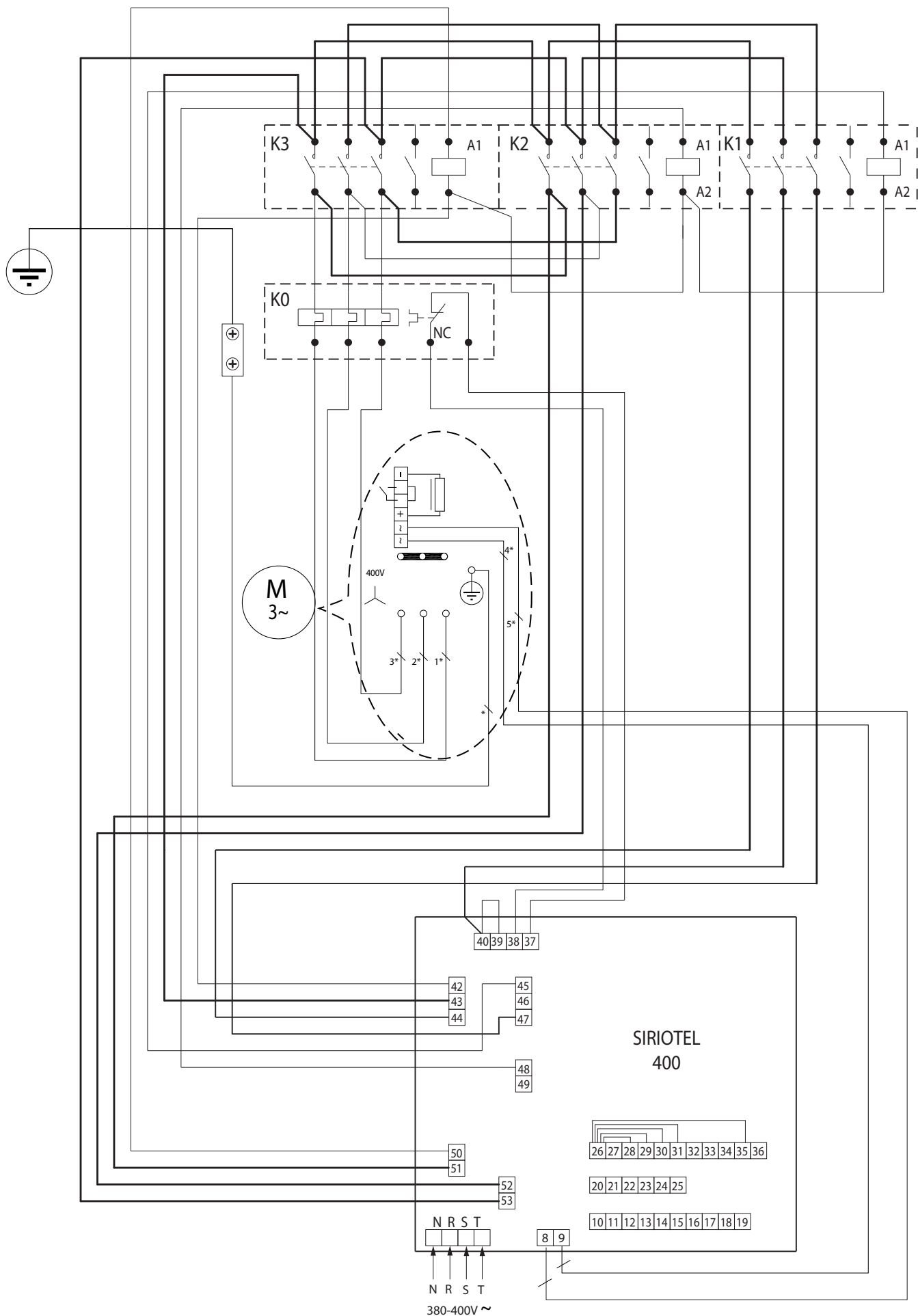

N R S T  
 N R S T  
 380-400V ~

SIRIOTEL  
 400

\* 7 x 1,5 mm<sup>2</sup>

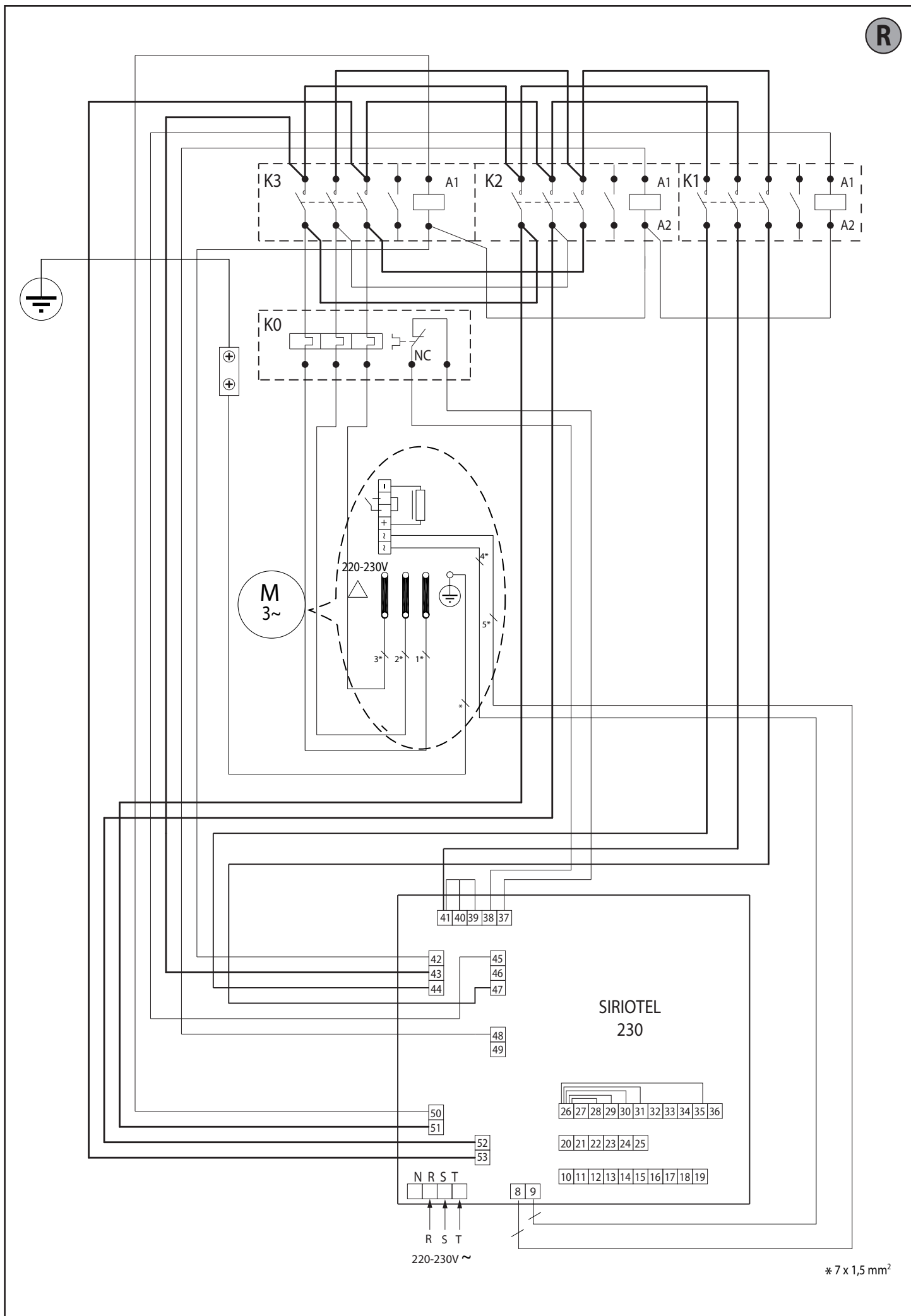

## INSTALLER WARNINGS

D811727 00100\_10

**WARNING! Important safety instructions. Carefully read and comply with all the warnings and instructions that come with the product as incorrect installation can cause injury to people and animals and damage to property. The warnings and instructions give important information regarding safety, installation, use and maintenance. Keep hold of instructions so that you can attach them to the technical file and keep them handy for future reference.**

### GENERAL SAFETY

This product has been designed and built solely for the purpose indicated herein. Uses other than those indicated herein might cause damage to the product and create a hazard.

- The units making up the machine and its installation must meet the requirements of the following European Directives, where applicable: 2004/108/EC, 2006/95/EC, 2006/42/EC, 89/106/EC, 99/05/EC and later amendments. For all countries outside the EEC, it is advisable to comply with the standards mentioned, in addition to any national standards in force, to achieve a good level of safety.
- The Manufacturer of this product (hereinafter referred to as the "Firm") disclaims all responsibility resulting from improper use or any use other than that for which the product has been designed, as indicated herein, as well as for failure to apply Good Practice in the construction of entry systems (doors, gates, etc.) and for deformation that could occur during use.
- Installation must be carried out by qualified personnel (professional installer, according to EN 12635), in compliance with Good Practice and current code.
- Before installing the product, make all structural changes required to produce safety gaps and to provide protection from or isolate all crushing, shearing and dragging hazard areas and danger zones in general in accordance with the provisions of standards EN 12604 and 12453 or any local installation standards. Check that the existing structure meets the necessary strength and stability requirements.
- Before commencing installation, check the product for damage.
- The Firm is not responsible for failure to apply Good Practice in the construction and maintenance of the doors, gates, etc. to be motorized, or for deformation that might occur during use.
- Make sure the stated temperature range is compatible with the site in which the automated system is due to be installed.
- Do not install this product in an explosive atmosphere: the presence of flammable fumes or gas constitutes a serious safety hazard.
- Disconnect the electricity supply before performing any work on the system. Also disconnect buffer batteries, if any are connected.
- Before connecting the power supply, make sure the product's ratings match the mains ratings and that a suitable residual current circuit breaker and overcurrent protection device have been installed upline from the electrical system. Have the automated system's mains power supply fitted with a switch or omnipolar thermal-magnetic circuit breaker with a contact separation that provide full disconnection under overvoltage category III conditions.
- Make sure that upline from the mains power supply there is a residual current circuit breaker that trips at no more than 0.03A as well as any other equipment required by code.
- Make sure the earth system has been installed correctly: earth all the metal parts belonging to the entry system (doors, gates, etc.) and all parts of the system featuring an earth terminal.
- Installation must be carried out using safety devices and controls that meet standards EN 12978 and EN 12453.
- Impact forces can be reduced by using deformable edges.
- In the event impact forces exceed the values laid down by the relevant standards, apply electro-sensitive or pressure-sensitive devices.
- Apply all safety devices (photocells, safety edges, etc.) required to keep the area free of impact, crushing, dragging and shearing hazards. Bear in mind the standards and directives in force, Good Practice criteria, intended use, the installation environment, the operating logic of the system and forces generated by the automated system.
- Apply all signs required by current code to identify hazardous areas (residual risks). All installations must be visibly identified in compliance with the provisions of standard EN 13241-1.
- Once installation is complete, apply a nameplate featuring the door/gate's data.
- This product cannot be installed on leaves incorporating doors (unless the motor can be activated only when the door is closed).
- If the automated system is installed at a height of less than 2.5 m or is accessible, the electrical and mechanical parts must be suitably protected.
- Install any fixed controls in a position where they will not cause a hazard, away from moving parts. More specifically, hold-to-run controls must be positioned within direct sight of the part being controlled and, unless they are key operated, must be installed at a height of at least 1.5 m and in a place where they cannot be reached by the public.
- Apply at least one warning light (flashing light) in a visible position, and also attach a Warning sign to the structure.
- Attach a label near the operating device, in a permanent fashion, with information on how to operate the automated system's manual release.
- Make sure that, during operation, mechanical risks are avoided or relevant protective measures taken and, more specifically, that nothing can be banged, crushed, caught or cut between the part being operated and surrounding parts.
- Once installation is complete, make sure the motor automation settings are correct and that the safety and release systems are working properly.
- Only use original spare parts for any maintenance or repair work. The Firm disclaims all responsibility for the correct operation and safety of the automated system if parts from other manufacturers are used.
- Do not make any modifications to the automated system's components unless explicitly authorized by the Firm.
- Instruct the system's user on what residual risks may be encountered, on the control systems that have been applied and on how to open the system manually in an emergency. Give the user guide to the end user.
- Dispose of packaging materials (plastic, cardboard, polystyrene, etc.) in accordance with the provisions of the laws in force. Keep nylon bags and polystyrene out of reach of children.

### WIRING

**WARNING!** For connection to the mains power supply, use: a multicore cable with a cross-sectional area of at least 5x1.5mm<sup>2</sup> or 4x1.5mm<sup>2</sup> when dealing with three-phase power supplies or 3x1.5mm<sup>2</sup> for single-phase supplies (by way of example, type H05 VV-F cable can be used with a cross-sectional area of 4x1.5mm<sup>2</sup>). To connect auxiliary equipment, use wires with a cross-sectional area of at least 0.5 mm<sup>2</sup>.

- Only use pushbuttons with a capacity of 10A-250V or more.
- Wires must be secured with additional fastening near the terminals (for example, using cable clamps) in order to keep live parts well separated from safety extra low voltage parts.
- During installation, the power cable must be stripped to allow the earth wire to be connected to the relevant terminal, while leaving the live wires as short as possible. The earth wire must be the last to be pulled taut in the event the cable's fastening device comes loose.

**WARNING!** safety extra low voltage wires must be kept physically separate from low voltage wires.

Only qualified personnel (professional installer) should be allowed to access live parts.

### CHECKING THE AUTOMATED SYSTEM AND MAINTENANCE

Before the automated system is finally put into operation, and during maintenance work, perform the following checks meticulously:

- Make sure all components are fastened securely.
- Check starting and stopping operations in the case of manual control.
- Check the logic for normal or personalized operation.
- For sliding gates only: check that the rack and pinion mesh correctly with 2 mm of play along the full length of the rack; keep the track the gate slides on clean and free of debris at all times.
- For sliding gates and doors only: make sure the gate's running track is straight and horizontal and that the wheels are strong enough to take the weight of the gate.
- For cantilever sliding gates only: make sure there is no dipping or swinging during operation.
- For swing gates only: make sure the leaves' axis of rotation is perfectly vertical.
- For barriers only: before opening the door, the spring must be decompressed (vertical boom).
- Check that all safety devices (photocells, safety edges, etc.) are working properly and that the anti-crush safety device is set correctly, making sure that the force of impact measured at the points provided for by standard EN 12445 is lower than the value laid down by standard EN 12453.
- Impact forces can be reduced by using deformable edges.
- Make sure that the emergency operation works, where this feature is provided.
- Check opening and closing operations with the control devices applied.
- Check that electrical connections and cabling are intact, making extra sure that insulating sheaths and cable glands are undamaged.
- While performing maintenance, clean the photocells' optics.
- When the automated system is out of service for any length of time, activate the emergency release (see "EMERGENCY OPERATION" section) so that the operated part is made idle, thus allowing the gate to be opened and closed manually.
- If the power cord is damaged, it must be replaced by the manufacturer or their technical assistance department or other such qualified person to avoid any risk.
- If "D" type devices are installed (as defined by EN 12453), connect in unverified mode, foresee mandatory maintenance at least every six months
- The maintenance described above must be repeated at least once yearly or at shorter intervals where site or installation conditions make this necessary.

### WARNING!

Remember that the drive is designed to make the gate/door easier to use and will not solve problems as a result of defective or poorly performed installation or lack of maintenance



### SCRAPPING

Materials must be disposed of in accordance with the regulations in force. Do not throw away your discarded equipment or used batteries with household waste. You are responsible for taking all your waste electrical and electronic equipment to a suitable recycling centre.

### DISMANTLING

If the automated system is being dismantled in order to be reassembled at another site, you are required to:

- Cut off the power and disconnect the whole electrical system.
- Remove the actuator from the base it is mounted on.
- Remove all the installation's components.
- See to the replacement of any components that cannot be removed or happen to be damaged.

**THE DECLARATION OF CONFORMITY CAN BE VIEWED ON THIS WEBSITE: WWW.BFT.IT IN THE PRODUCT SECTION.**

**Anything that is not explicitly provided for in the installation manual is not allowed. The operator's proper operation can only be guaranteed if the information given is complied with. The Firm shall not be answerable for damage caused by failure to comply with the instructions featured herein.**

**While we will not alter the product's essential features, the Firm reserves the right, at any time, to make those changes deemed opportune to improve the product from a technical, design or commercial point of view, and will not be required to update this publication accordingly.**

## 1) GENERAL INFORMATION

The SP3500 operator consists of a strong gearmotor. The self-braking motor and irreversible gearbox allow the gate to stop quickly, avoiding uncontrolled sliding of the gate due to the effect of inertia. The gearmotor is coupled to the gate by means of a rack. The control panel is built in and comprises: start relay, three-phase motor protector, control unit. The operating logic provides for various configurations so that use of the automated device can be tailored to the user's needs (e.g.: automatic closing, controlled closing, photocells active during closing etc.). To edit settings, call in qualified personnel (installer). The irreversible gearmotor keeps the gate locked closed, meaning there is no need to use solenoid locks. A manual release system allows the gate to be opened manually in the event of a mains power outage or malfunctioning.

In deadman mode, check the gate stopping distance: if it exceeds 50mm, cover the closing edge with a rubber profile whose deformation is greater than the stopping distance and results in less than 150N of static force being generated on a test body measuring 80mm in diameter.

## 2) TECHNICAL SPECIFICATIONS

| MOTOR                        |  |
|------------------------------|--|
| Power supply*                | SIRIOTEL 400: 3-phase + N 380-400V~50/60Hz<br>SIRIOTEL 230: 3-phase + 220-230V~50/60Hz |
| Power demand                 | 0.55 kW  |
| Max. current demand          | 2A (380-400V); 3A (220-230V)   |
| Protection                   | motor protector wired in panel   |
| Insulation class             | F  |
| Reduction ratio              | 1/50   |
| Pinion module                | m=6mm z=19 teeth   |
| Maximum leaf weight          | 35000N (~3500kg)   |
| Leaf speed                   | 10.5 m/min   |
| Impact reaction              | stop (with safety edge)  |
| Gearbox lubrication          | oil  |
| Manual operation             | key-operated mechanical release  |
| Control unit                 | SIRIO TEL with interface   |
| Environmental conditions     | from -15°C to +50°C  |
| Protection rating            | IP 54  |
| Dimensions                   | Fig. J   |
| Operator weight              | 54 kg.   |
| Max. travel                  | 30 m   |
| Out speed                    | 28 rpm   |
| Use                          | 100% up to 2200 kg. / 60% over 2200 kg.  |
| CONTROL UNIT                 |  |
| Power supply                 | 3-phase + N 380-400V~:3-phase 220-230V~ 50/60Hz  |
| Low voltage/mains insulation | > 2M0hm 500V---  |
| LV/mains dielectric rigidity | 3750V~ 1'  |
| Accessories power supply     | 24V~/0.5A  |
| Gate open light              | 24V/3W   |

(\* Special supply voltages to order.

(\* 3-phase 220-230V power supply available.

## 3) TUBE ARRANGEMENT Fig.A

Install the electrical system referring to the standards in force for electrical systems CEI 64-8, IEC 364, harmonization document HD 384 and other national standards.

## 4) PREPARATION FOR MOTOR MOUNTING FIG. B-K

• Make a hole in the ground to accommodate the concrete pad, with anchors embedded in the base plate for fastening the gearbox assembly, keeping to the distances featured in **FIG.B**.

## 5) MOUNTING THE MOTOR FIG.C

## 6) MOUNTING DRIVE ACCESSORIES FIG.D-D1

## 7) RACK CENTRING WITH RESPECT TO PINION FIG.L

**⚠ DANGER - Welding must be performed by a competent person issued with the necessary personal protective equipment as prescribed by the safety rules in force.**

## 8) FASTENING LIMIT SWITCH BRACKETS FIG.E

## 9) STOPS FIG.M

**⚠ DANGER - The gate must be fitted with mechanical stops to halt its travel both when opening and closing, thus preventing the gate from coming off the top guide. Said stops must be fastened firmly to the ground, a few centimetres beyond the electric stop point.**

## 10) MANUAL RELEASE (See USER GUIDE -FIG.2-).

**Warning: do not JERK the gate open and closed, instead push it GENTLY to the end of its travel.**

## 11) MOTOR PROTECTOR FIG. N

Make sure it is set for the motor's rated current demand (380-400V/2A) (220-230V/3A).

## 12) CHECKING DIRECTION FIG.N1

Release the motor and move the gate half way along its travel. Relock the motor then turn the power off and back on. Give the start command. If the gate does not move in the opening direction, swap the phase wires over. **WARNING:** also check that limit switches SWO-SWC are working properly.

## 13) TERMINAL BOARD WIRING FIG. F-G

Once suitable electric cables have been run through the raceways and the automated device's various components have been fastened at the predetermined points, connect them as directed and illustrated in the diagrams contained in the relevant instruction manuals.

Connect the live, neutral and earth wire (compulsory) **Fig. Q-R**.

| TERMINAL         | DEFINITION                      | DESCRIPTION   |
|------------------|---------------------------------|---|
| 1<br>2<br>3<br>4 | <b>N<br/>R<br/>S<br/>T</b>      | Three-phase <b>power supply 380-400V~</b> , 50-60Hz<br>N NEUTRAL<br>R LINE 1<br>S LINE 2<br>T LINE 3  |
| 2<br>3<br>4      | <b>R<br/>S<br/>T</b>            | Three-phase <b>power supply 220-230V~</b> , 50-60Hz<br>R LINE 1<br>S LINE 2<br>T LINE 3   |
| 8-9              | <b>BLINK 230V</b>               | Flashing light 230V output max. 40W.  |
| 10-11            | <b>SCA</b>                      | Free contact (N.O.).<br>Gate Open Light output SCA 24V~ max. 3W.  |
| 11               | <b>24V AUX ~</b>                | Accessories power supply:<br>24V~ operation with mains power on.  |
| 12               | <b>0V AUX ~</b>                 |   |
| 12               | <b>Vsafe -</b>                  | Safety device power supply output (photocell transmitter and safety edge transmitter).<br>N.B.: output active only during operating cycle.<br>24V~ Vsafe operation with mains power on.   |
| 13               | <b>Vsafe +</b>                  |   |
| 14               | <b>LOOP 1</b>                   | Safety device test input LOOP 1 (see fig.G)   |
| 15               | <b>LOOP 2</b>                   | Safety device test input LOOP 2 (see fig.G)   |
| 16-17            | <b>2°CH.R</b>                   | Free contact (N.O.).<br>2nd radio channel output. 24V~ max. 3W.   |
| 18<br>19         | <b>ANT<br/>SHIELD</b>           | Antenna (18 signal - 19 braiding).<br>Use an antenna tuned to 433MHz. Use RG58 coax cable to connect the Antenna and Receiver. Metal bodies close to the antenna can interfere with radio reception. If the transmitter's range is limited, move the antenna to a more suitable position. |
| 20-21-22         | <b>INPUTS OF TESTED DEVICES</b> | Tested safety device connection (see fig.O-P)   |
| 23-24-25         | <b>INPUTS OF TESTED DEVICES</b> | Tested safety device connection (see fig.O-P)   |
| 26-27            | <b>START</b>                    | START command input (N.O.).<br>Operation according to 2-4-step logic.   |
| 26-28            | <b>STOP</b>                     | STOP input (N.C.)<br>The command stops movement.<br>If not used, leave jumper inserted.   |
| 26-29            | <b>PHOT</b>                     | PHOTOCELL input (N.C.) Operation according to photocell during opening logic. If not used, leave jumper inserted.   |
| 26-30            | <b>SWO</b>                      | Opening limit switch SWO (N.C.). If not used, leave jumper inserted.  |
| 26-31            | <b>SWC</b>                      | Closing limit switch SWC (N.C.). If not used, leave jumper inserted.  |
| 26-32            | <b>PED</b>                      | PEDESTRIAN command input (N.O.) The command causes the automated device to open to the pedestrian opening position.   |
| 26-33            | <b>OPEN</b>                     | OPEN command input (N.O.) The command causes the leaves to open. If the contact stays closed, the leaves stay open until the contact is opened. When the contact is open, the automated device closes following the TCA time, where activated.  |
| 26-34            | <b>CLOSE</b>                    | CLOSE command input (N.O.).<br>The command causes the leaves to close.  |
| 26-35            | <b>BAR</b>                      | Safety edge input BAR (N.C.).<br>The command reverses movement for 2 sec.<br>If not used, leave jumper inserted.  |
| 36               | Not used                        | Not used  |
| 40-53            |                                 | See wiring fig. Q-R   |

# INSTALLATION MANUAL

D811727 00100\_10

## 14) TRIMMER

| Trimmer | Min. | Max. | Definition                 | Description  |
|---------|------|------|----------------------------|--|
| TCA     | 1    | 120  | Automatic closing time [s] | Waiting time before automatic closing.   |
| TW      | 2    | 210  | Motor work time [s]        | Time motor(s) is/are powered for   |
| TW.PED  | 5    | 60   | Pedestrian work time [s]   | Partial opening time for motor 2 following activation of PED pedestrian command. |

## 15) DIP SWITCH

| DIP | Default | Definition                  | Cross out setting used | Description  |
|-----|---------|-----------------------------|------------------------|--|
| 1-2 | OFF     | Photocells during opening   | ON                     | In the event beam is broken, photocell operation is disabled during opening. During closing, movement is reversed immediately. Logic enabled on Phot input.  |
|     |         |                             | OFF                    | In the event beam is broken, photocells are active during both opening and closing. When beam is broken during closing, movement is reversed only once the photocell is cleared. Logic active on Phot input. |
| 3   | OFF     | Block pulses during opening | ON                     | The start pulse has no effect during opening.  |
|     |         |                             | OFF                    | The start pulse has effect during opening.   |
| 4   | ON      | Automatic Closing Time      | ON                     | Switches automatic closing on  |
|     |         |                             | OFF                    | Switches automatic closing off   |
| 5   | OFF     | 2-step logic                | ON                     | Switches to 2-step logic; with each pulse, start reverses movement.  |
|     |         |                             | OFF                    | Switches to 4-step logic.  |
| 6   | OFF     | Pre-alarm                   | ON                     | The flashing light comes on approx. 3 seconds before the motor(s) start.   |
|     |         |                             | OFF                    | The flashing light comes on at the same time as the motor(s) start.  |
| 7   | OFF     | Deadman                     | ON                     | Affects signals connected to terminals 26-33 and 26-34. Deadman mode: operation continues as long as the OPEN and CLOSE control keys are held down.  |
|     |         |                             | OFF                    | Pulse operation, according to 2, 3 or 4-step logic.  |
| 8   | OFF     | Reduced work time scale     | ON                     | TW work time falls within the range 1 to 90 seconds (pedestrian work time TW.PED range from 1 to 20 seconds)   |
|     |         |                             | OFF                    | TW work time falls within the range 3 to 210 seconds (pedestrian work time TW.PED range from 5 to 60 seconds).   |
| 9   | ON      | Photocell test              | ON                     | Switches photocell testing off. Inhibits the photocell testing function, enabling connection of devices not equipped with supplementary test contacts.   |
|     |         |                             | OFF                    | Switches photocell testing on (Fig. O-P)   |
| 10  | ON      | Safety edge testing         | ON                     | Switches safety edge testing off. Inhibits the safety edge testing function, enabling connection of devices not equipped with supplementary test contacts.   |
|     |         |                             | OFF                    | Switches safety edge testing on (Fig. O-P)   |

## 16) DIAGNOSTICS and WARNINGS

| Diagnostics code | Description  | Notes |
|------------------|--|-------|
| DL1              | Steadily lit:<br>- Mains power on - Board powered - Fuse F1 intact     |       |
| DL2              | On when motor is activated during closing.                             |       |
| DL3              | On when motor is activated during opening.                             |       |
| DL4              | On:<br>-START input activated<br>-Radio receiver 1st channel activated |       |
| DL5              | Off:<br>-STOP input activated  |       |
| DL6              | Off:<br>-PHOT photocell input activated                                |       |
| DL7              | Off:<br>-SWC closing limit switch input activated                      |       |
| DL8              | Off:<br>-SWO opening limit switch input activated                      |       |
| DL9              | On:<br>-PED pedestrian input activated                                 |       |
| DL10             | On:<br>-OPEN pedestrian input activated                                |       |
| DL11             | On:<br>-CLOSE pedestrian input activated                               |       |
| DL12             | Off:<br>-BAR safety edge input activated                               |       |
| DL13             | On:<br>-With safety loop closed  |       |

## 17) SAFETY DEVICES

**Note: only use receiving safety devices with free changeover contact.**

### 17.1) TESTED DEVICES (Fig.O-P)

### 17.2) NON-TESTED DEVICES (Fig.H) one pair of photocells and one safety edge.

### 18) WIRING DIAGRAM FOR BUILT-IN CONTROL UNIT Fig.Q-R

Fig.2

MANUALE D'USO: MANOVRA MANUALE/ USER'S MANUAL: MANOVRA MANUALE/ MANUEL D'UTILISATION: MANOVRA MANUALE/  
BEDIENUNGSANLEITUNG: MANOVRA MANUALE/ MANUEL DE USO: MANOVRA MANUALE/ MANUAL PARA DE USO: MANOVRA MANUALE

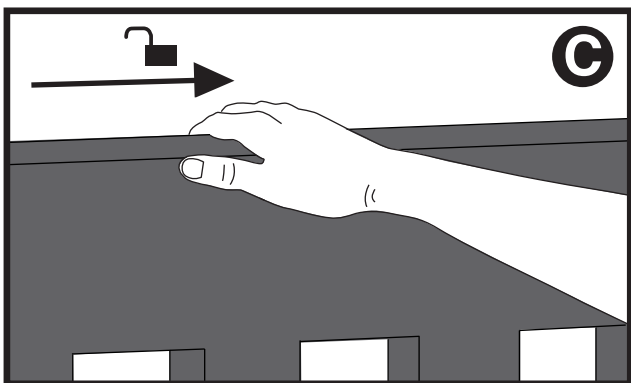
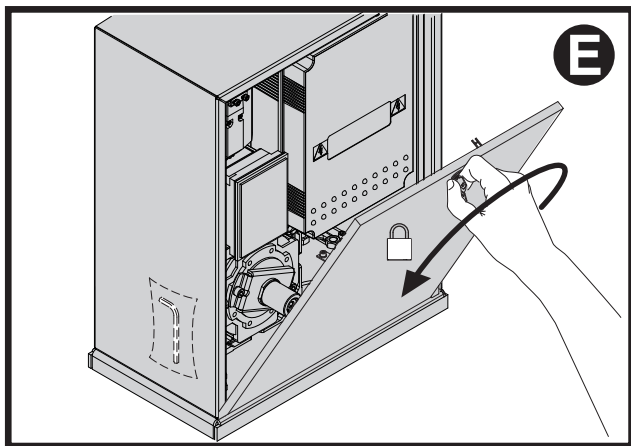
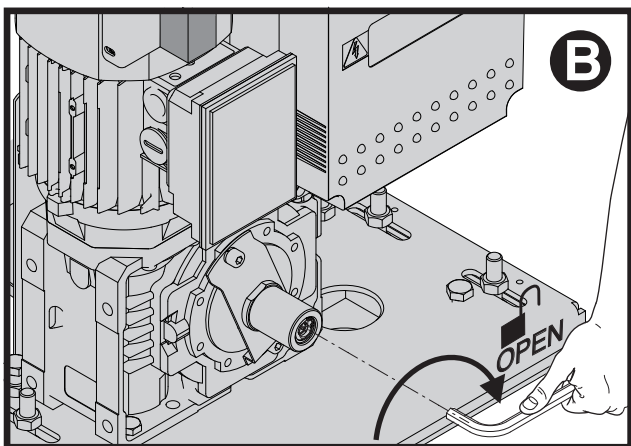
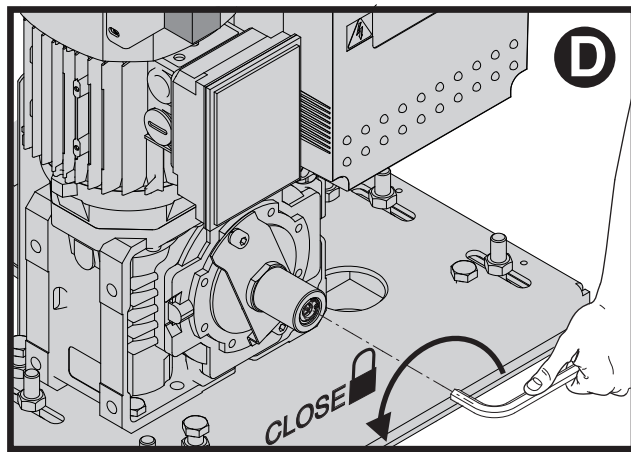
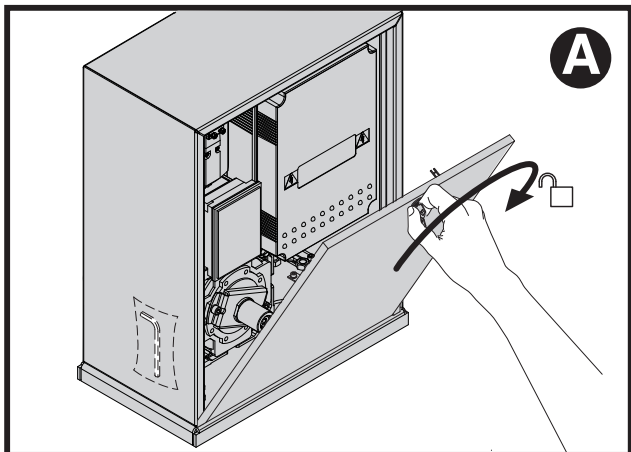

## AVVERTENZE PER L'UTILIZZATORE ( I )

**ATTENZIONE! Importanti istruzioni di sicurezza. Leggere e seguire attentamente le Avvertenze e le Istruzioni che accompagnano il prodotto poiché un uso improprio può causare danni a persone, animali o cose. Conservare le istruzioni per consultazioni future e trasmetterle ad eventuali subentranti nell'uso dell'impianto.**

**Questo prodotto dovrà essere destinato solo all'uso per il quale è stato espressamente installato. Ogni altro uso è da considerarsi improprio e quindi pericoloso. Il costruttore non può essere considerato responsabile per eventuali danni causati da usi impropri, erronei e irragionevoli.**

**SICUREZZA GENERALE**  
Nel ringraziarVi per la preferenza accordata a questo prodotto, la Ditta è certa che da esso otterrete le prestazioni necessarie al Vostro uso.

Questo prodotto risponde alle norme riconosciute della tecnica e della disposizioni relative alla sicurezza se correttamente installato da personale qualificato ed esperto (installatore professionale). L'automazione, se installata ed utilizzata correttamente, soddisfa gli standard di sicurezza nell'uso. Tuttavia è opportuno osservare alcune regole di comportamento per evitare inconvenienti accidentali:

- Tenere bambini, persone e cose fuori dal raggio d'azione dell'automazione, in particolare durante il movimento.
- Non permettere a bambini di giocare o sostare nel raggio di azione dell'automazione.
- Questa automazione non è destinata all'uso da parte di bambini o da parte di persone con ridotte capacità mentali, fisiche e sensoriali, o persone che mancano di conoscenze adeguate a meno che esse non abbiano potuto beneficiare, attraverso l'intermediazione di una persona responsabile della loro sicurezza, di una sorveglianza o di istruzioni riguardanti l'uso dell'apparecchio.
- I bambini devono essere sorvegliati per sincerarsi che non giochino con l'apparecchio. Non permettere ai bambini di giocare con i controlli fissi. Tenere i telecomandi lontani dai bambini.
- Evitare di operare in prossimità delle cerniere o organi meccanici in movimento.
- Non contrastare il movimento dell'anta e non tentare di aprire manualmente la porta se non è stato sbloccato l'attuatore con l'apposita manopola di sblocco.
- Non entrare nel raggio di azione della porta o cancello motorizzati durante il loro movimento.
- Non lasciare radiocomandi o altri dispositivi di comando alla portata dei bambini onde evitare azionamenti involontari.
- L'attivazione dello sblocco manuale potrebbe causare movimenti incontrollati della porta se in presenza di guasti meccanici o di condizioni di squilibrio.
- In caso di apertapparelle: sorvegliare la tapparella in movimento e tenere lontano le persone finché non è completamente chiusa. Porre cura quando si aziona lo sblocco se presente, poiché una tapparella aperta potrebbe cadere rapidamente in presenza di usura o rotture.
- La rottura o l'usura di organi meccanici della porta (parte guidata), quali ad esempio cavi, molle, supporti, cardini, guide.. potrebbe generare pericoli. Far controllare periodicamente l'impianto da personale

qualificato ed esperto (installatore professionale) secondo quanto indicato dall'installatore o dal costruttore della porta.

- Per ogni operazione di pulizia esterna, togliere l'alimentazione di rete.
- Tenere pulite le ottiche delle fotocellule ed i dispositivi di segnalazione luminosa. Controllare che rami ed arbusti non disturbino i dispositivi di sicurezza.
- Non utilizzare l'automatismo se necessita di interventi di riparazione. In caso di guasto o di malfunzionamento dell'automazione, togliere l'alimentazione di rete sull'automazione, astenersi da qualsiasi tentativo di riparazione o intervento diretto e rivolgersi solo a personale qualificato ed esperto (installatore professionale) per la necessaria riparazione o manutenzione. Per consentire l'accesso, attivare lo sblocco di emergenza (se presente).
- Per qualsiasi intervento diretto sull'automazione o sull'impianto non previsto dal presente manuale, avvalersi di personale qualificato ed esperto (installatore professionale).
- Con frequenza almeno annuale far verificare l'integrità e il corretto funzionamento dell'automazione da personale qualificato ed esperto (installatore professionale), in particolare di tutti i dispositivi di sicurezza.
- Gli interventi d'installazione, manutenzione e riparazione devono essere documentati e la relativa documentazione tenuta a disposizione dell'utilizzatore.
- Il mancato rispetto di quanto sopra può creare situazioni di pericolo.



### DEMOLIZIONE

L'eliminazione dei materiali va fatta rispettando le norme vigenti. Non gettate il vostro apparecchio scartato, le pile o le batterie usate nei rifiuti domestici. Avete la responsabilità di restituire tutti i vostri rifiuti da apparecchiature elettriche o elettroniche lasciandoli in un punto di raccolta dedicato al loro riciclo.

**Tutto quello che non è espressamente previsto nel manuale d'uso, non è permesso. Il buon funzionamento dell'operatore è garantito solo se vengono rispettate le prescrizioni riportate in questo manuale. La Ditta non risponde dei danni causati dall'inosservanza delle indicazioni riportate in questo manuale.**

**Lasciando inalterate le caratteristiche essenziali del prodotto, la Ditta si riserva di apportare in qualunque momento le modifiche che essa ritiene convenienti per migliorare tecnicamente, costruttivamente e commercialmente il prodotto, senza impegnarsi ad aggiornare la presente pubblicazione.**

## USER WARNINGS (GB)

**WARNING! Important safety instructions. Carefully read and comply with the Warnings and Instructions that come with the product as improper use can cause injury to people and animals and damage to property. Keep the instructions for future reference and hand them on to any new users.**

**This product is meant to be used only for the purpose for which it was explicitly installed. Any other use constitutes improper use and, consequently, is hazardous. The manufacturer**



cannot be held liable for any damage as a result of improper, incorrect or unreasonable use.

## GENERAL SAFETY

Thank you for choosing this product. The Firm is confident that its performance will meet your operating needs.

This product meets recognized technical standards and complies with safety provisions when installed correctly by qualified, expert personnel (professional installer).

If installed and used correctly, the automated system will meet operating safety standards. Nonetheless, it is advisable to observe certain rules of behaviour so that accidental problems can be avoided:

- Keep adults, children and property out of range of the automated system, especially while it is moving.
- Do not allow children to play or stand within range of the automated system.
- This automated system is not meant for use by children or by people with impaired mental, physical or sensory capacities, or people who do not have suitable knowledge, unless a person who is responsible for their safety provides them with necessary supervision or instructions on how to use the device.
- Children must be supervised to ensure they do not play with the device. Do not allow children to play with the fixed controls. Keep remote controls out of reach of children.
- Do not work near hinges or moving mechanical parts.
- Do not hinder the leaf's movement and do not attempt to open the door manually unless the actuator has been released with the relevant release knob.
- Keep out of range of the motorized door or gate while they are moving.
- Keep remote controls or other control devices out of reach of children in order to avoid the automated system being operated inadvertently.
- The manual release's activation could result in uncontrolled door movements if there are mechanical faults or loss of balance.
- When using roller shutter openers: keep an eye on the roller shutter while it is moving and keep people away until it has closed completely. Exercise care when activating the release, if such a device is fitted, as an open shutter could drop quickly in the event of wear or breakage.
- The breakage or wear of any mechanical parts of the door (operated part), such as cables, springs, supports, hinges, guides..., may generate a hazard. Have the system checked by qualified, expert personnel (professional installer) at regular intervals according to the instructions issued by the installer or manufacturer of the door.
- When cleaning the outside, always cut off mains power.
- Keep the photocells' optics and illuminating indicator devices clean. Check that no branches or shrubs interfere with the safety devices.
- Do not use the automated system if it is in need of repair. In the event the automated system breaks down or malfunctions, cut off mains power to the system; do not attempt to repair or perform any other work to rectify the fault yourself and instead call in qualified, expert personnel (professional installer) to perform the necessary repairs or maintenance. To allow access, activate the emergency release (where fitted).
- If any part of the automated system requires direct

work of any kind that is not contemplated herein, employ the services of qualified, expert personnel (professional installer).

- At least once a year, have the automated system, and especially all safety devices, checked by qualified, expert personnel (professional installer) to make sure that it is undamaged and working properly.
- A record must be made of any installation, maintenance and repair work and the relevant documentation kept and made available to the user on request.
- Failure to comply with the above may result in hazardous situations.



## SCRAPPING

Materials must be disposed of in accordance with the regulations in force. Do not throw away your discarded equipment or used batteries with household waste. You are responsible for taking all your waste electrical and electronic equipment to a suitable recycling centre.

**Anything that is not explicitly provided for in the user guide is not allowed. The operator's proper operation can only be guaranteed if the instructions given herein are complied with. The Firm shall not be answerable for damage caused by failure to comply with the instructions featured herein.**

**While we will not alter the product's essential features, the Firm reserves the right, at any time, to make those changes deemed opportune to improve the product from a technical, design or commercial point of view, and will not be required to update this publication accordingly.**

## AVERTISSEMENTS POUR L'UTILISATEUR (F)

**ATTENTION ! Instructions de sécurité importantes. Veuillez lire et suivre attentivement tous les avertissements et toutes les instructions fournis avec le produit sachant qu'un usage incorrect peut provoquer des préjudices aux personnes, aux animaux ou aux biens. Veuillez conserver les instructions pour d'ultérieures consultations et pour les transmettre aux propriétaires futurs éventuels.**

**Cet appareil ne peut être destiné qu'à l'usage pour lequel il a été expressément installé. Tout autre usage sera considéré comme impropre et donc dangereux. Le fabricant ne sera en aucun cas considéré comme responsable des préjudices dus à un usage impropre, erroné ou déraisonné.**

## SECURITE GÉNÉRALE

Nous vous remercions d'avoir choisi ce produit qui, nous n'en doutons pas, saura vous garantir les performances attendues.

Ce produit, correctement installé par du personnel qualifié et expérimenté (monteur professionnel) est conforme aux normes reconnues de la technique et des prescriptions de sécurité.

Si l'automatisation est montée et utilisée correctement, elle garantit la sécurité d'utilisation prescrite. Il est cependant nécessaire de respecter certaines règles de comportement pour éviter tout inconvénient accidentel.

- Tenir les enfants, les personnes et les objets à l'écart du rayon d'action de l'automatisation, en particulier pendant son fonctionnement.
- Empêcher les enfants de jouer ou de stationner dans le rayon d'action de l'automatisation.

**Bft Spa**  
Via Lago di Vico, 44  
36015 Schio (VI)  
T +39 0445 69 65 11  
F +39 0445 69 65 22  
→ [www.bft.it](http://www.bft.it)



**SPAIN**  
**BFT GROUP ITALIBERICA DE AUTOMATISMOS S.L.**  
08401 Granollers - (Barcelona)  
[www.bftautomatismos.com](http://www.bftautomatismos.com)

**FRANCE**  
**AUTOMATISMES BFT FRANCE**  
69800 Saint Priest  
[www.bft-france.com](http://www.bft-france.com)

**GERMANY**  
**BFT TORANTRIEBSSYSTEME GmbH**  
90522 Oberasbach  
[www.bft-torantriebe.de](http://www.bft-torantriebe.de)

**UNITED KINGDOM**  
**BFT AUTOMATION UK LTD**  
Stockport, Cheshire, SK7 5DA  
[www.bft.co.uk](http://www.bft.co.uk)

**IRELAND**  
**BFT AUTOMATION LTD**  
Dublin 12

**BENELUX**  
**BFT BENELUX SA**  
1400 Nivelles  
[www.bftbenelux.be](http://www.bftbenelux.be)

**POLAND**  
**BFT POLSKA SP. Z O.O.**  
05-091 ZABKI  
[www.bft.pl](http://www.bft.pl)

**CROATIA**  
**BFT ADRIA D.O.O.**  
51218 Drazice (Rijeka)  
[www.bft.hr](http://www.bft.hr)

**PORTUGAL**  
**BFT SA-COMERCIO DE AUTOMATISMOS E MATERIAL DE SEGURANCIA**  
3020-305 Coimbra  
[www.bftportugal.com](http://www.bftportugal.com)

**CZECH REPUBLIC**  
**BFT CZ S.R.O.**  
Praha  
[www.bft.it](http://www.bft.it)

**TURKEY**  
**BFT OTOMATIK KAPI SISTEMELERI SANAY VE**  
Istanbul  
[www.bftotomasyon.com.tr](http://www.bftotomasyon.com.tr)

**RUSSIA**  
**BFT RUSSIA**  
111020 Moscow  
[www.bftorus.ru](http://www.bftorus.ru)

**AUSTRALIA**  
**BFT AUTOMATION AUSTRALIA PTY LTD**  
Wetherill Park (Sydney)  
[www.bftaustralia.com.au](http://www.bftaustralia.com.au)

**U.S.A.**  
**BFT USA**  
Boca Raton  
[www.bft-usa.com](http://www.bft-usa.com)

**CHINA**  
**BFT CHINA**  
Shanghai 200072  
[www.bft-china.cn](http://www.bft-china.cn)

**UAE**  
**BFT Middle East FZCO**  
Dubai