



# FAST SLIDING GATES

Fast electromechanical automation  
for sliding gates

ELDOGE



Be ahead

# What is U-Link?

The technology that gives you more power

U-Link, Universal Link, is an exclusive BFT platform that can be used to create high-tech ecosystems.

In Home Access Automation, it can be used to communicate with all home access automation devices of any brand.

This saves you time and allows you to control everything easily and worry-free.

## It is intuitive

Easy to install and to use

## It is scalable

You can add as many devices as you want

## It is flexible

It allows you to create groups of interconnected products

## It is practical

Works with or without an internet connection

## It is functional

It can be configured remotely using dedicated applications

## Everything on one screen: find out more about this amazing technology

A world-exclusive platform that can be used to create high-tech ecosystems offering a vast range of solutions for many different sectors.

This proprietary platform which is a key feature of BFT products, thanks to the B-EBA cards and the Clonix U-Link receiver, is suitable for any protocol or product for access automation (including BFT products, non-BFT ones and older versions) and it can be used in a variety of different sectors. This means any device becomes a smart device which can be interconnected with other systems, using a language that is becoming universal.



**U-Control HOME** U-Control HOME is the application that allows you to open the gate to your home and to remotely control BFT automations using your own smartphone. The iOS version can be used to automatically open the entrance system when you are close to it.



**U-SDK** U-SDK is the application which allows BFT automations to be made compatible and easily integrated with a BMS network.



**U-Base 2**  
A software package used for easily and conveniently installing, performing maintenance and identifying any faults in the U-Link compatible operators, easily and conveniently.

conveniently installing, performing maintenance and identifying any faults in the U-Link compatible operators, easily and conveniently.

U-Base 2

SOLUTIONS  
BFT

BFT  
PRODUCTS  
BASED ON  
U-LINK

SECTORS OF  
APPLICATION

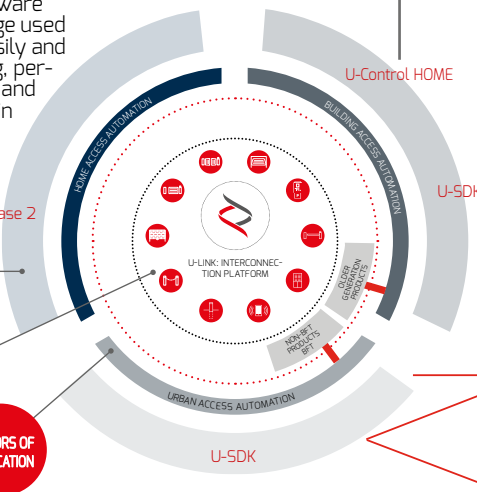

U-Control HOME

U-SDK



Clonix U-Link  
Connect non-native U-Link and non-BFT products to U-Link systems.

Is it possible to connect non-native U-Link BFT operators or other brands of products to U-Link? Yes, thanks to the Clonix receivers. Accessories which accept no limits.



B-EBA  
A direct link to your operators.

The B-EBA expansion cards make it possible to connect external devices such as PCs, smartphones and tablets to a BFT operator and a Clonix receiver or to connect multiple BFT products in a U-Link network.

# Fast-Action Operators for sliding gates

  
**Maximum  
Speed**

**25**  
m/min

**20**  
m/min

**15**  
m/min

**10**  
m/min

**5**  
m/min

**ARES VELOCE  
SMART BT A 500**



**500**  **25**

**ICARO VELOCE  
SMART AC A 1000**



**1000**  **25**

**ARES VELOCE  
SMART BT A 1000**



**1000**  **18**

**ICARO VELOCE  
SMART AC A 2000**



**2000**  **18**

**DEIMOS / ARES / ICARO**  
standard operators for sliding gates

  
**Maximum  
Weight**

**500**  
Kg

**1000**  
Kg

**1500**  
Kg

**2000**  
Kg



# ARES VELOCE SMART BT A



24 V



d-track



U-Link



Emergency stop ready



U-Link



Empowered by  
**U-LINK**

## VELOCE

Fast-action 24 V operator for intensive use for sliding gates up to 500 kg and speed without load 25 m/min, or up to 1,000 kg and speed without load up to 18 m/min (the maximum speed achievable by the gate depends on its weight and condition). Torque control thanks to D-Track technology. Control unit for communication with U-Link protocol. Operator with electromagnetic limit switch. The ideal solution for situations which require fast operating speeds, reduced waiting times and high levels of security.

## ARES VELOCE SMART BT A |

	Code	Name	Description
	P926198 00002	<b>ARES VELOCE SMART BT A 500 230V 50/60HZ</b>	24 V operator for sliding gates weighing up to 500 kg. Speed without load 25 m/min. U-Link and electromagnetic limit switch. 230 V 50/60Hz power supply.
	P926198 00001	<b>ARES VELOCE SMART BT A500 120V 60HZ</b>	24 V operator for sliding gates weighing up to 500 kg. Speed without load 25 m/min. U-Link and electromagnetic limit switch. Power supply 120 V 60 Hz.
	P926199 00002	<b>ARES VELOCE SMART BT A1000</b>	24 V operator for sliding gates weighing up to 1,000 kg. Speed without load 18 m/min. U-Link and electromagnetic limit switch. 230 V 50/60Hz power supply.

## Benefits of ARES VELOCE SMART BT A



**Speed:** The fast opening of the ARES SMART BT A reduces waiting times and allowing quicker access, reducing the risk of an accident.



security

**Security:** The fast operating speed means that the ARES VELOCE SMART BT A closes quickly, reducing the risk of entry by unauthorised people.



**U-Link:** The ARES VELOCE SMART BT A operator is compatible with the U-Link communication protocol, through the integrated MERAK SV 24 V control panel.



d-track

**D-Track:** An intelligent torque management system which updates the level of torque required to perform the operation, allowing it work at the optimum level regardless of weather conditions, temperature or the degree of wear and tear on the device.



**Personalised key:** the lever release makes it easy to release the motor and the personalised key is unique, providing increased security.



**Screws on the front:** By putting the fastening screws on the front of the casing, installation and maintenance are easier and more convenient, even in confined spaces.



- Integrated control panel for the ARES VELOCE SMART BT A 24 V operator. Main features: removable colour coded terminal blocks, digital display for programming scenarios, integrated two-channel receiver, slowdown during opening and closing. Main functions: automatic closing, fast closing, pedestrian opening, hold-to-run operation, maintenance notification.

	<b>ARES VELOCE SMART BT A500 230V 50/60HZ</b>	<b>ARES VELOCE SMART BT A500 120V 60HZ</b>	<b>ARES VELOCE SMART BT A1000 230V 50/60HZ</b>
Control unit	MERAK SV		
Panel power supply	230V 50/60Hz	120V 60Hz	230V 50/60Hz
Motor voltage	24V		
Power consumption	400W		
Pinion module	M4 Z25		M4 Z18
Speed without load	25m/min		18m/min
max. weight	500kg		1000kg
max. torque	20Nm		
Impact reaction	8K2 safety edge (not supplied)		
Locking	Mechanical		
Manual operation	Mechanical release with lever		
Type of use	Intensive		
Protection rating	IP24		
Environmental conditions	-20 ÷ +55°C		

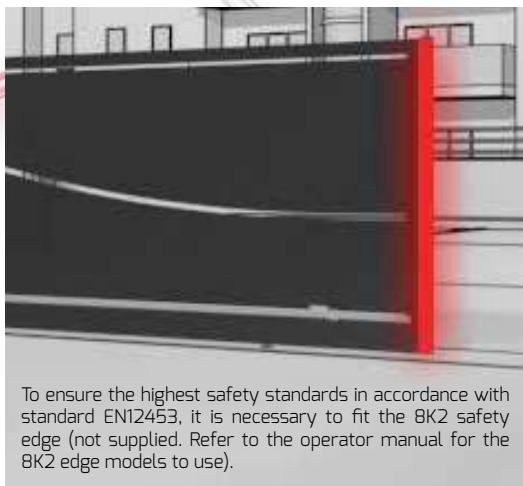





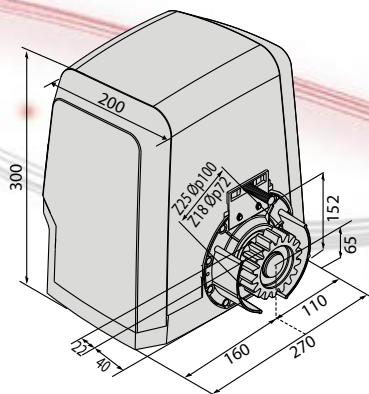

To ensure the highest safety standards in accordance with standard EN12453, it is necessary to fit the 8K2 safety edge (not supplied. Refer to the operator manual for the 8K2 edge models to use).

## Dimensions



## RECOMMENDED ACCESSORIES

	<b>D571054 - CFZ</b> Galvanized steel rack, module 4, 22 x 22 mm cross-section, length 2 m, fastened by welding. Maximum load 2,000 kg.
	<b>P125018 - THEKE B PRA 01</b> Metal protective casing for sliding operators, ARES and ICARO series
	<b>P125035 - SL BAT2</b> Emergency battery kit
	<b>N999156 - SFI</b> Mounting plate for ARES and ICARO (supplied with the operator)
	<b>P111468 - B EBA RS 485 LINK</b> Expansion card for connection of groups of units with serial command management
	<b>D114093 00003 - RADIUS LED BT A R1</b> Flashing with LED technology and built-in receiver antenna. 24V power supply
	<b>D114168 00003 - RADIUS LED BT A R1 W</b> Flashing with LED technology, built-in receiver antenna and smoky grey cover. 24V power supply.
	<b>P111528 - THEA A15 O.PF</b> Pair of adjustable photocells with built-in flashing light. Possibility to direct the beam 40° horizontally and 10° vertically. Synchronised infrared signal to avoid any possibility of blinding. 30 m range. 24 V ac/dc power supply. For external application.
	<b>P111782 - COMPACTA</b> Set of photocells adjustable 180° horizontally 20 metre range. 12-33Vac / 15-35Vdc power supply.
	<b>D111904 - MITTO B RCB02 R1</b> 2-Channel transmitter. 50/100 m range. 12 V power supply with 1 type 23 A battery
	<b>D111906 - MITTO B RCB04 R1</b> 4-Channel transmitter. 50/100 m range. 12 V power supply with 1 type 23 A battery
	<b>R920110 - XL-CP99A36/KT/2000/8K/5</b> Kit for 8k2 resistive safety edges, length 2 metres, with 99 mm-high EPDM rubber strip, aluminium section, 2 contact terminals, 2 caps, 1 x 8.2 kOhm resistance connector and connection cable.
	<b>R920111 - KIT WIRELESSBAND 2.R</b> Wireless transmission system for resistive safety edges comprising transmitter and receiver.
	<b>P125050 - TX WIRELESSBAND 2.R</b> Wireless transmitter for resistive safety edges.



# ICARO VELOCE SMART AC A

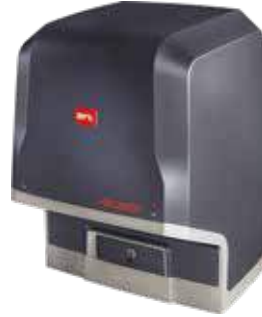

Fast-action 230 V operator for intensive use for sliding gates up to 1,000 kg and speed without load 25 m/min, or up to 2,000 kg and speed without load up to 18 m/min (the maximum speed achievable by the gate depends on its weight and condition). Extremely robust and high-performance thanks to the oil bath transmission. Torque control thanks to D-Track technology and encoder for the highest possible precision of movement. Control unit for communication with U-Link protocol and with tamper-proof function. Operator with electromagnetic limit switch. The ideal solution for situations which

## ICARO VELOCE SMART AC A | |

Code	Name	Description
 P925256 00002	<b>ICARO VELOCE SMART AC A 1000</b>	230 V operator with encoder for sliding gates weighing up to 1,000 kg and speed without load of 25 m/min. Electromechanical limit switch. With mechanical safety clutch, controls torque using D-Track technology and oil bath gearbox. Control unit for U-Link communication and with tamper-proof function.
P925256 00001	<b>ICARO VELOCE SMART AC A1000 120V</b>	120 V operator with encoder for sliding gates weighing up to 1,000 kg and speed without load of 25 m/min. Electromechanical limit switch. With mechanical safety clutch, controls torque using D-Track technology and oil bath gearbox. Control unit for U-Link communication and with tamper-proof function.
P925265 00002	<b>ICARO VELOCE SMART AC A2000</b>	230 V operator with encoder for sliding gates weighing up to 2,000 kg and speed without load of 18 m/min. Electromechanical limit switch. With mechanical safety clutch, controls torque using D-Track technology and oil bath gearbox. Control unit for U-Link communication and with tamper-proof function.

## Benefits of ICARO VELOCE SMART AC A



**Speed:** The fast opening of the ICARO VELOCE SMART AC A reduces waiting times, allowing quicker access, particularly useful for commercial and industrial sites.



security

**Security:** The fast operating speed means that the ICARO VELOCE SMART AC A closes quickly, reducing the risk of entry by unauthorised people.



U-LINK

**U-Link:** The ICARO VELOCE SMART AC A operator is compatible with the U-Link communication protocol, through the integrated LEO B CBB control panel.



d-track

**D-Track:** An intelligent torque management system which updates the level of torque required to perform the operation, allowing it work at the optimum level regardless of weather conditions, temperature or the degree of wear and tear on the device.



Oil Gear

**Oil Gear:** Oil bath gearbox unit. The component gears of the transmission are immersed in an oil bath to ensure perfect lubrication throughout their service life.



**Technopolymers:** The combined use of metal and plastic-technopolymer gears provides the perfect engagement between the surfaces, allowing for reduced friction and the highest levels of reliability in intensive use.



**Personalised key:** the lever release makes it easy to release the motor and the personalised key is unique, providing increased security.



**Screws on the front:** By putting the fastening screws on the front of the casing, installation and maintenance are easier and more convenient, even in confined spaces.

## LEO B CBB LO2



- Specific integrated control panel for the ICARO VELOCE SMART AC A operator. Main features: removable colour coded terminal blocks, digital display for programming scenarios, integrated two-channel receiver, torque control with D-Track technology, slowdown during opening and closing. Main functions: automatic closing, fast closing, pedestrian opening.

	ICARO VELOCE SMART AC A1000 230V 50/60HZ	ICARO VELOCE SMART AC A1000 120V 60HZ	ICARO VELOCE SMART AC A2000 230V 50/60HZ
Control unit	LEO B CBB LO2		
Panel power supply	230V 50/60Hz	120V 60Hz	230V 50/60Hz
Motor voltage	230V	120V	230V
Power consumption	750W		
Pinion module	M4 Z25	M4 Z18	M4 Z18
Speed without load	25m/min	22m/min	18m/min
max. weight	1000kg		2000kg
max. torque	40Nm		
Impact reaction	BK2 safety edge (not supplied)		
Locking	Mechanical		
Manual operation	Mechanical release with lever		
Type of use	Very intensive		
Protection rating	IP24		
Environmental conditions	-15 ÷ +55°C		







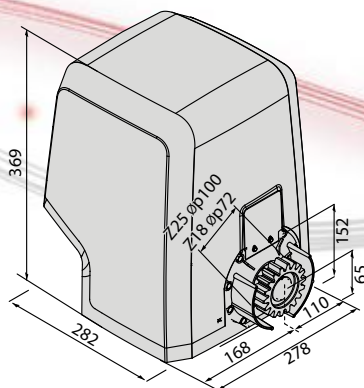



To ensure the highest safety standards in accordance with standard EN12453, it is necessary to fit the BK2 safety edge (not supplied). Refer to the operator manual for the BK2 edge models to use).

## Dimensions



## RECOMMENDED ACCESSORIES

	D571054 - <b>CFZ</b> Galvanized steel rack, module 4, 22 x 22 mm cross-section, length 2 m, fastened by welding. Maximum load 2,000 kg.
	P125018 - <b>THEKE B PRA 01</b> Metal protective casing for sliding operators, ARES and ICARO series
	N999156 - <b>SFI</b> Mounting plate for ARES and ICARO (supplied with the operator)
	P111468 - <b>B EBA RS 485 LINK</b> Expansion card for connection of groups of units with serial command management
	D114093 00002 - <b>RADIUS LED AC A R1</b> Flashing with LED technology and built-in receiver antenna. 230V power supply.
	P111528 - <b>THEA A15 O.PF</b> Pair of adjustable photocells with built-in flashing light. Possibility to direct the beam 40° horizontally and 10° vertically. Synchronised infrared signal to avoid any possibility of blinding. 30 m range. 24 V ac/dc power supply. For external application.
	P111782 - <b>COMPACTA</b> Set of photocells adjustable 180° horizontally 20 metre range. 12-33Vac / 15-35Vdc power supply.
	D111904 - <b>MITTO B RCB02 R1</b> 2-Channel transmitter. 50/100 m range. 12 V power supply with 1 type 23 A battery
	D111906 - <b>MITTO B RCB04 R1</b> 4-Channel transmitter. 50/100 m range. 12 V power supply with 1 type 23 A battery
	R920110 - <b>XL-CP99A36/KT/2000/8K/5</b> Kit for 8k2 resistive safety edges, length 2 metres, with 99 mm-high EPDM rubber strip, aluminium section, 2 contact terminals, 2 caps, 1 x 8.2 kOhm resistance connector and connection cable.
	R920111 - <b>KIT WIRELESSBAND 2.R</b> Wireless transmission system for resistive safety edges comprising transmitter and receiver.
	P125050 - <b>TX WIRELESSBAND 2.R</b> Wireless transmitter for resistive safety edges.

The contents of this catalogue (images, technical descriptions, illustrations) are the sole property of BFT SpA. Its reproduction, in any form or format, is strictly forbidden. All rights reserved, copyright 2016. The information contained in this publication is to be considered indicative. BFT reserves the right to make changes without giving any prior notice. Cover Designed by Freepik



**Bft SpA**

Via Lago di Vico, 44 - 36015 Schio (Vicenza), Italy  
Dedicated Direct Telephone Number 06 96 706 706  
for professionals working in the sector.

[www.bft-automation.com](http://www.bft-automation.com)



8 027908 566638

leaflet battenti veloci ENG  
0833212 0A103



Be ahead