

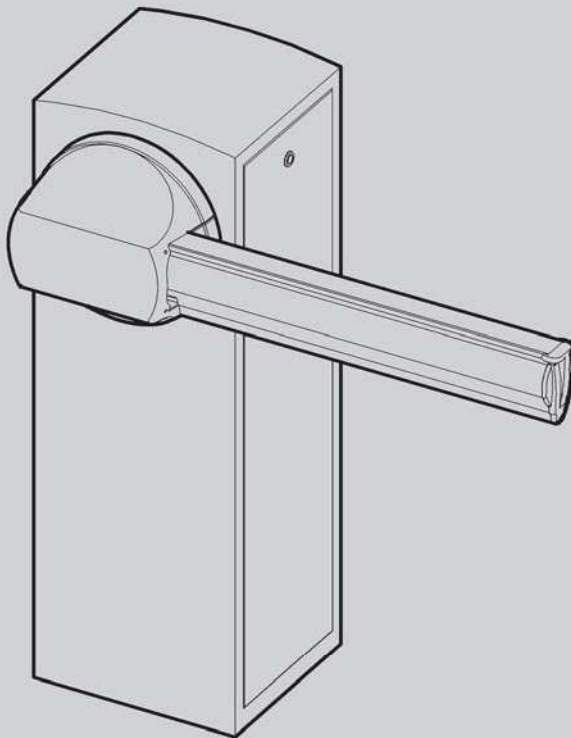

BARRIERA AUTOMATICA
AUTOMATIC BARRIER
BARRIÈRE AUTOMATIQUE
AUTOMATISCHE SCHRANKE
BARRERA AUTOMÁTICA



ISTRUZIONI D'USO E DI INSTALLAZIONE
INSTALLATION AND USER'S MANUAL
INSTRUCTIONS D'UTILISATION ET D'INSTALLATION
INSTALLATIONS-UND GEBRAUCHSANLEITUNG
INSTRUCCIONES DE USO Y DE INSTALACION

MAXIMA ULTRA 68

Bft

Attenzione! Leggere attentamente le "Avvertenze" all'interno! **Caution!** Read "Warnings" inside carefully! **Attention!** Veuillez lire attentivement les Avertissements qui se trouvent à l'intérieur!
Achtung! Bitte lesen Sie aufmerksam die „Hinweise“ im Inneren! **Atención!** Leer atentamente las "Advertencias" en el interior! **Let op!** Lees de "Waarschuwingen" aan de binnenkant zorgvuldig!



Index

1. General information

1.1	Introduction.....	pag.10
1.2	General safety.....	pag.10
1.3	General.....	pag.10
1.4	Technical specification.....	pag.10
1.5	Overall dimensions.....	pag.11

2. Installation

2.1	Cable note.....	pag.11
2.2	Fixing the structure.....	pag.11
2.3	Springs mounting.....	pag.12
2.4	Instal the arm.....	pag.13

2.5	Align the arm.....	pag.13
2.6	Balancing the arm.....	pag.14
2.7	Optionals.....	pag.14
2.8	Electrical connections.....	pag.14

3. Use and maintenance

3.1	General safety.....	pag.15
3.2	Warnings.....	pag.15
3.3	Use.....	pag.15
3.4	Manual manoeuvre.....	pag.15
3.5	Routine maintenance.....	pag.15

1.1 INTRODUCTION



Please read it carefully before installing the appliance, before using it and before routine or extraordinary maintenance work.



The notices preceded by this symbol provide important information, the non-compliance with such instructions voids the manufacturer's guarantee.

OPERATIONS THAT, IF NOT CARRIED OUT CORRECTLY, CAN BE RISKY, ARE INDICATED WITH THE FOLLOWING SYMBOLS



ELECTROCUTION



CRUSHING

The INSTALLATION, USE AND MAINTENANCE handbook is for installers, users and maintenance engineers

The Company is not liable for injury to people or animals or damage to things in the case of applications that exceed the limits specified on the enclosed technical data sheet or by a use different from what the appliance has been designed.

Warning! Observe all the instructions, improper installation can result in serious injury.

1.2 GENERAL SAFETY

- Scrap packing materials (plastic, cardboard, polystyrene etc) according to the provisions set out by current standards. Keep nylon or polystyrene bags out of children's reach.
- Disconnect the electrical power supply before carrying out any work on the installation. Also disconnect any buffer batteries, if fitted.
- Fit an omnipolar or magnetothermal switch on the mains power supply, having a contact opening distance equal to or greater than 3,5 mm.
- Check that a differential switch with a 0,03A threshold is fitted just before the power supply mains.
- The outputs are not of type SELV (separated extra-low voltage), therefore it must not be possible to reach them.
- Fit all the safety devices (photocells, electric edges etc.) which are needed to protect the area from any danger caused by squashing, conveying and shearing, according to and in compliance with the applicable directives and technical standards.
- The Company declines all responsibility with respect to the automation safety and correct operation when other manufacturer's components are used.
- Only use original parts for any maintenance or repair operation.
- Do not modify the automation components, unless explicitly authorised by the Company.
- Instruct the product user about the control systems provided and the manual opening operation in case of emergency.
- Do not allow persons or children to remain in the automation operation area.
- Keep radio control or other control devices out of children's reach, in order to avoid unintentional automation activation.
- Do not allow children to play with the equipment.
- The equipment may be used by children aged over 8 years old and by people with reduced physical, sensory or mental capabilities, or without experience or the necessary knowledge, provided they are supervised or after they have received instructions relating to the safe use of the equipment and have understood the dangers inherent in it.
- Cleaning and maintenance meant to be performed by the user must not be performed by unsupervised children.
- Anything which is not expressly provided for in the present instructions, is not allowed.

1.3 GENERAL

The automatic electromechanical barrier is designed to control passage openings up to 8 metres wide, for a maximum torque applicable to the bar shaft of 1150 Nm, in compliance with European standards. It is suitable for industrial applications and it is the ideal solution for managing vehicle traffic.

1.4 TECHNICAL SPECIFICATIONS

Power.....	230Vac/115Vac ±10% 50/60Hz	Opening time.....	4.5 ÷ 6.0 s **	Net weight.....	95 kg
Motor.....	230Vac 900RPM 14uF 0.5kW	Arm length.....	4 ÷ 8 m	Gross weight.....	98 kg
Absorbed power.....	650W	Working temp.....	-30*** +60°C	Sound pressure level.....	LpA≤70 dB (A)
Control unit.....	CSB-Xtreme	Manoeuvres in 24h.....	3 000	** the opening times are considered from	
Impact safety.....	Encoder	Protection level.....	IP 54	closed bar to slow down start	
				*** With integrated heater active	

1.5 OVERALL DIMENSIONS

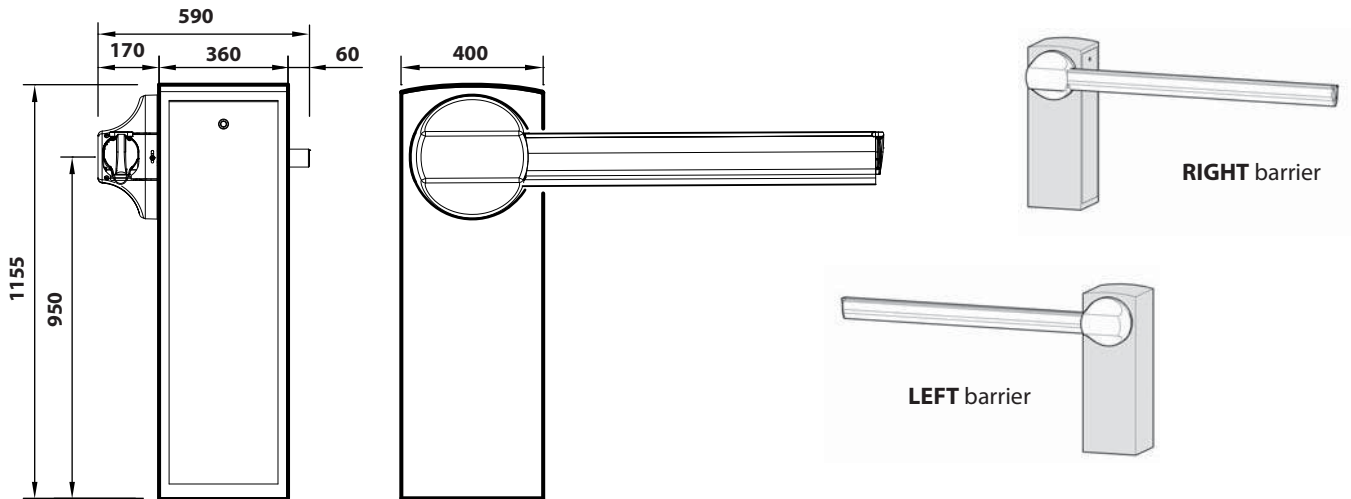

2.1 CABLE NOTE



1) Single-phase line	2 x 1,5 + E
2) Transmitter photocell	2 x 0,5
3) Receiver photocell	4 x 0,5
4) Flashing light	2 x 0,5
5) Key selector	3 x 0,5
6) Receiver	4 x 0,5
6) Antenna	RG58
7) Magnetic coil	

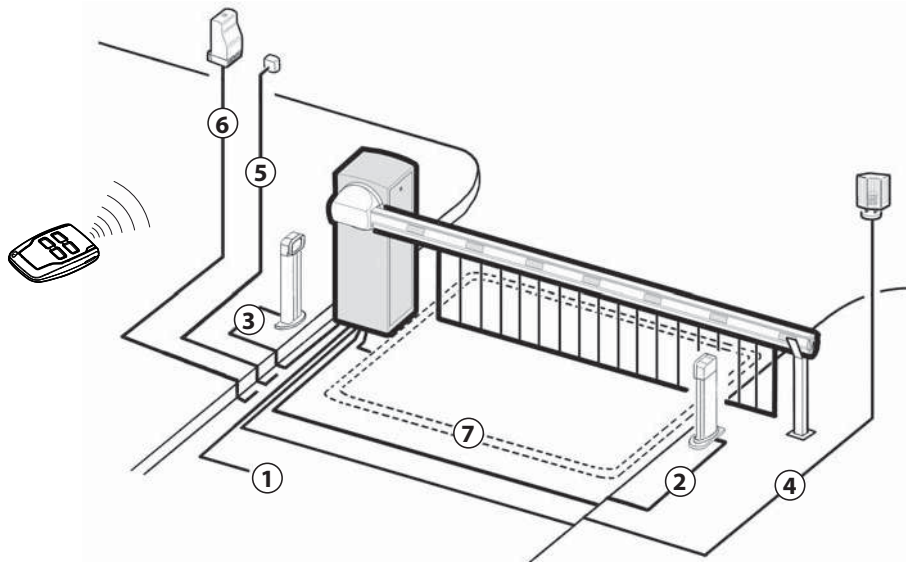

ENGLISH

2.2 FIXING THE STRUCTURE

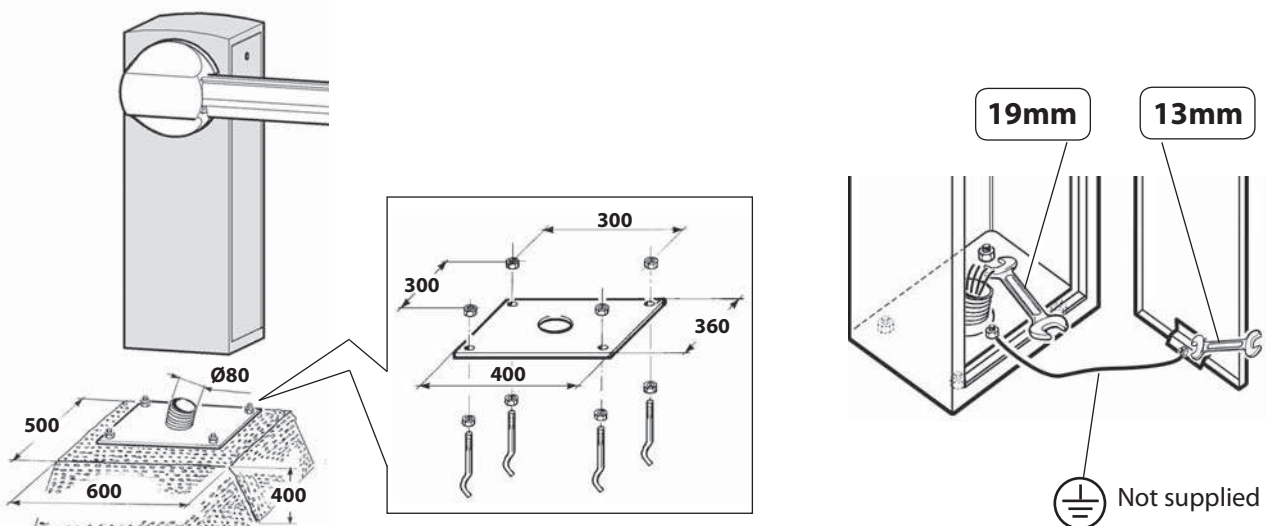

2.3 SPRINGS MOUNTING

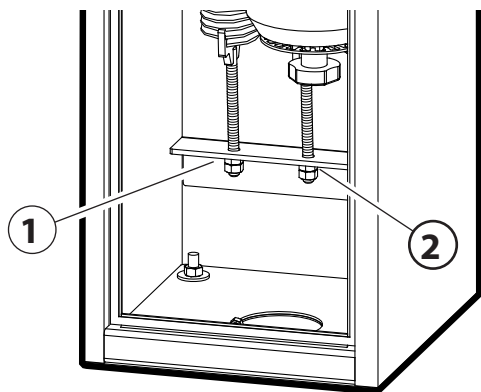

If single spring, mount in position 1

1

First mount spring 2 if present.

ENGLISH

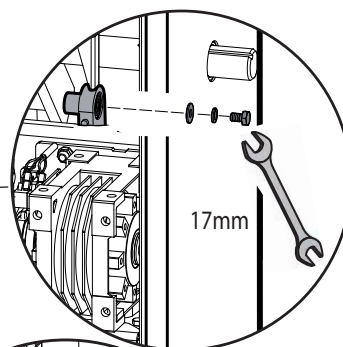
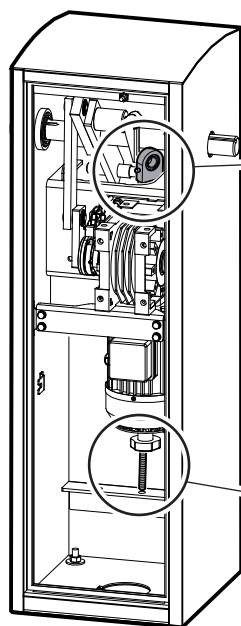
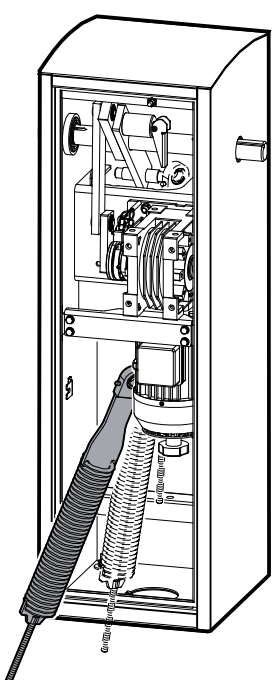

17mm

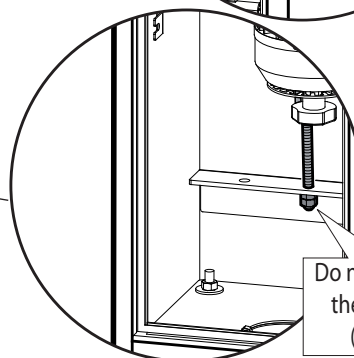

Do not tighten before the balancing arm (see point 2.6)

Mount spring 1.

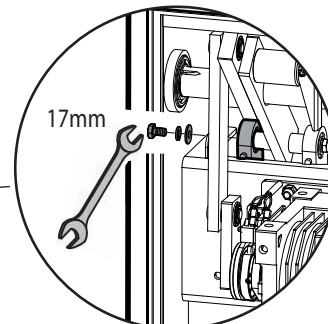
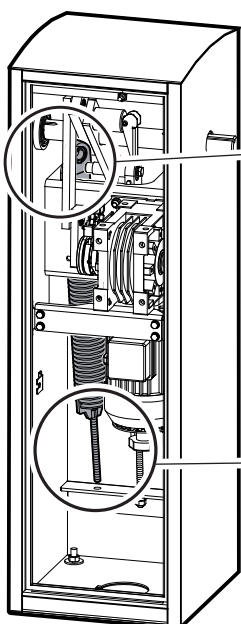
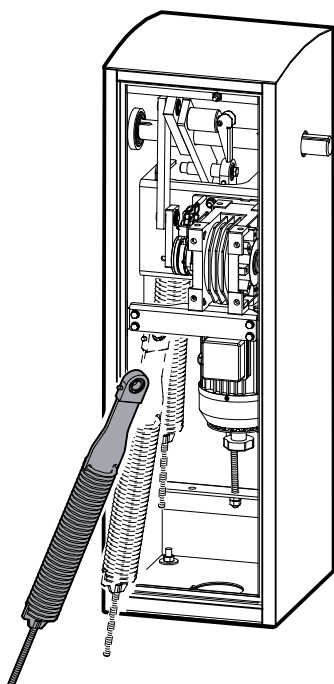

17mm

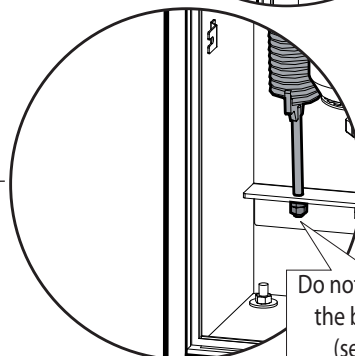

Do not tighten before the balancing arm (see point 2.6)

2.4 INSTALL THE ARM

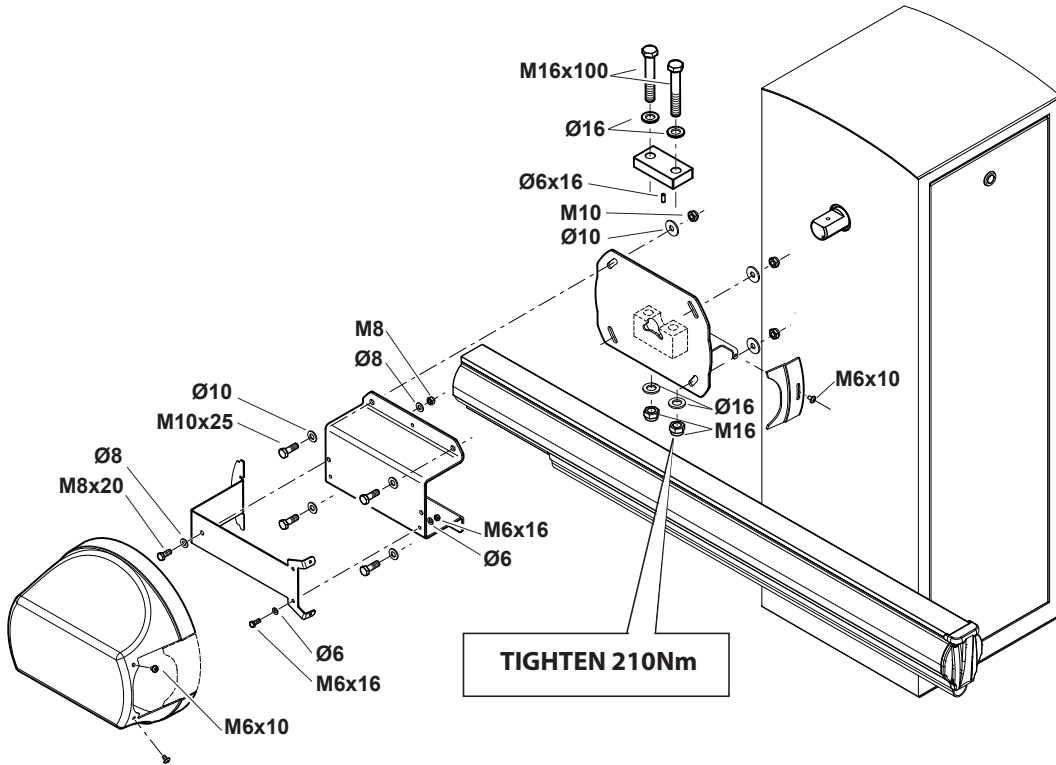

ENGLISH

2.5 ALIGN THE ARM



Electrically connect the control unit (see point 2.8)

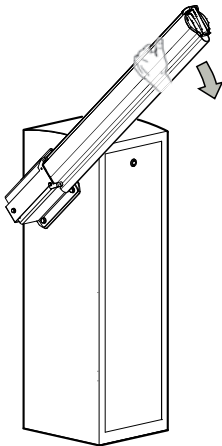

"START"



- Insert about 1 metre of the arm in the holder
- Give the "START" command to position the arm holder horizontally
- Pull the arm down to help the reducer counteract the force of the pre-calibrated spring

Install the arm and adjust the holder



USE THE ADJUSTABLE ARM HOLDER TO ALIGN THE ARM WITH THE ROAD.

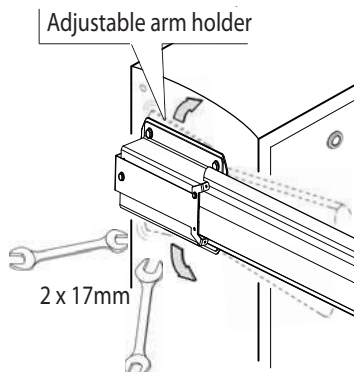

Check that the bar is in horizontal position

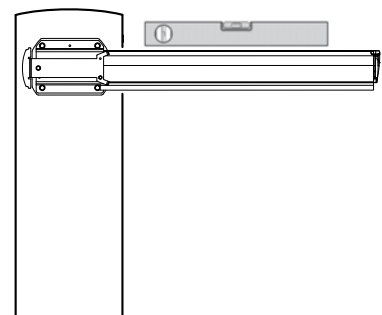

Give the "START" command to position the arm holder vertically

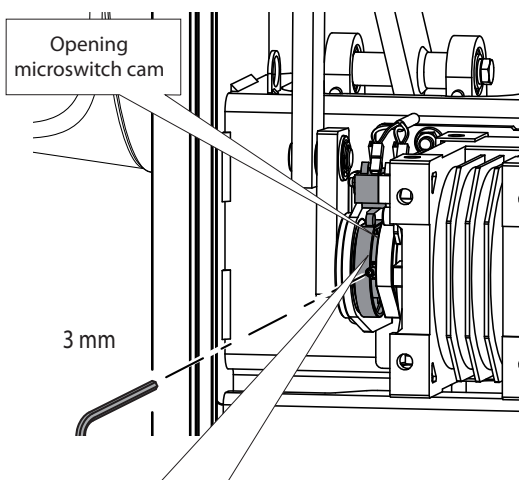
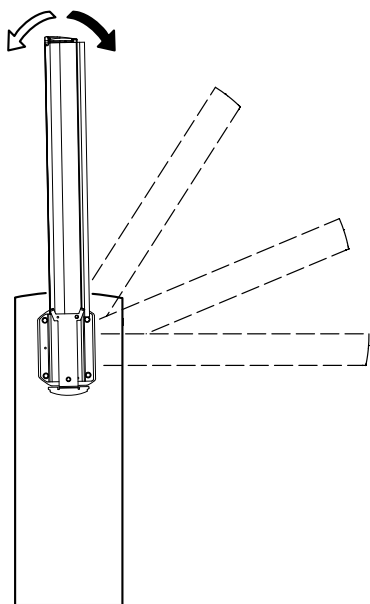

Check that the bar is in vertical position

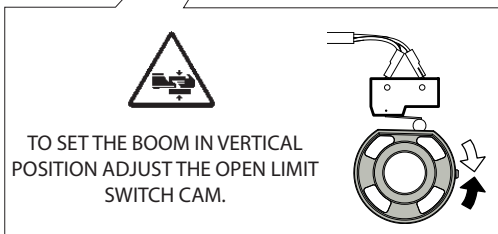
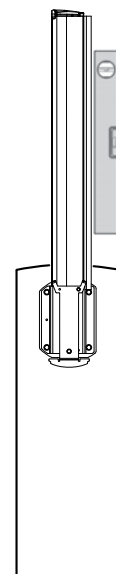

TO SET THE BOOM IN VERTICAL POSITION ADJUST THE OPEN LIMIT SWITCH CAM.

2.6 BALANCING THE ARM

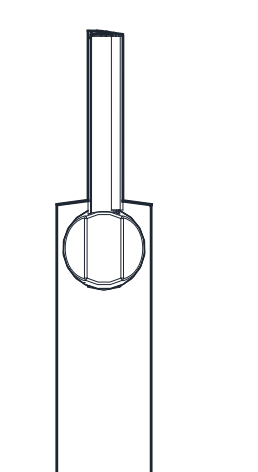

Put the bar in a vertical position.

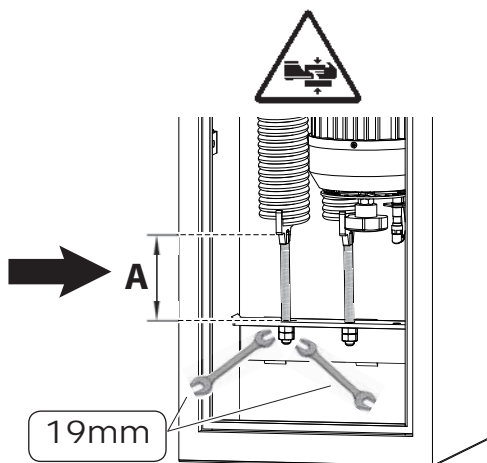

For the "A" value see **TAB.1** page 34

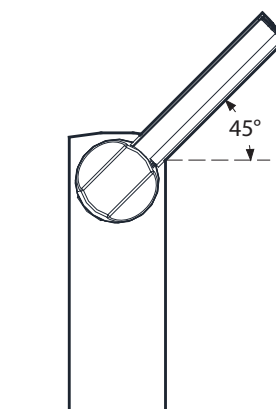

Check that the arm is balanced at ~45°

2.7 OPTIONALS

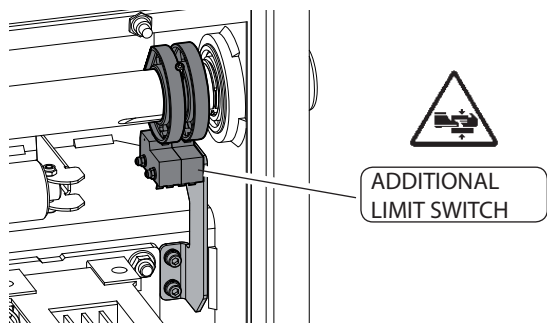

ADDITIONAL LIMIT SWITCH

2.8 ELECTRICAL CONNECTIONS

CSB-Xtreme

Consult the control unit's installation and operating manual

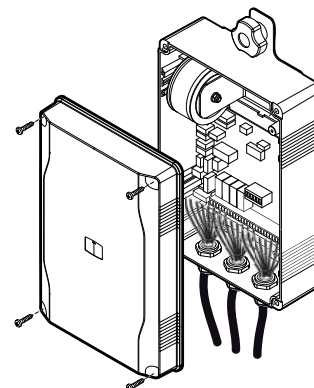

3.1 GENERAL SAFETY

- The barrier is designed exclusively for vehicles traffic; report and delimit any walkways through a special sign.
- Keep adults, children and property out of range of the automated system, especially while it is operating.
- For safety reasons and to comply with current standards, we recommend using the control unit.
- To install follow the instructions given in the enclosed "GENERAL INSTRUCTIONS FOR SAFETY" sheet.
- All electrical connections must be done in compliance with current laws.
- The installer must instruct the user on how to use the automatism correctly, on the manual emergency manoeuvre and on the possible risks during operation.
- Analyse the risks and take all the appropriate measures to eliminate them, as prescribed by the **EEC** machine directive **2006/42**, installing the safety devices.
- Always disconnect the electricity before attempting any work on the system with a lockable cut-off switch.
- Cleaning and maintenance meant to be performed by the user must not be performed by unsupervised children

3.2 WARNINGS

Correct controller operation is only ensured when the data contained in the present manual are observed. The Company is not to be held responsible for any damage resulting from failure to observe the installation standards and the instructions contained in the present manual.

The descriptions and illustrations contained in the present manual are not binding. The Company reserves the right to make any alterations deemed appropriate for the technical, manufacturing and commercial improvement of the product, while leaving the essential product features unchanged, at any time and without undertaking to update the present publication.

3.3 USE

- It is essential to follow the instructions given in the enclosed "GENERAL INSTRUCTIONS FOR SAFETY" sheet.
- **In the case of a manual emergency manoeuvre, follow the indications described in point 3.4.**
- Consult the control unit's installation and operating manual.

3.4 MANUAL MANOEUVRE

Always disconnect the electricity before attempting any work on the system



Releasing the barrier

WITH MOUNTED BOOM ONLY

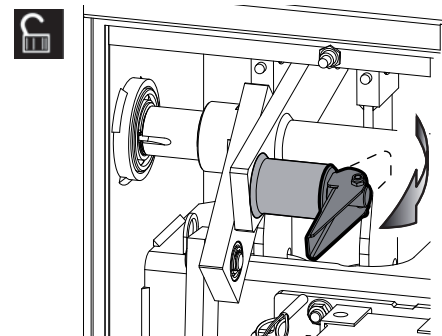
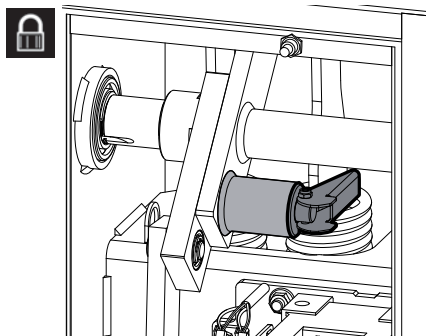
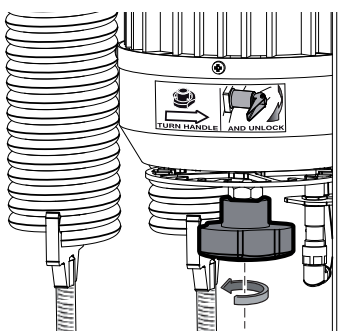

3.5 ROUTINE MAINTENANCE (EVERY 6 MONTHS)

- Maintenance must be carried out by qualified personnel only.
- Check the condition of the barrier structure.
- Check tightness of the arm.
- Check the condition of the spring, chain and relative anchorings.
- Check arm balance.
- Check that at the end of travel the arm is horizontal and/or vertical
- Check operation of the control unit and safety devices.
- Check operation of the manual emergency manoeuvre.
- Record maintenance in the form on the page 35.

Dati impianto • Installation data

Installatore <i>Installer</i>	
Cliente <i>Customer</i>	
Matricola <i>Serial number</i>	
Data installazione <i>Installation date</i>	
Data attivazione <i>Activation date</i>	
Luogo <i>Location</i>	

Nr.	Data • Date	Descrizione intervento • Intervention description	Firma • Signature
1			Tecnico • Technician
			Cliente • Customer
2			Tecnico • Technician
			Cliente • Customer
3			Tecnico • Technician
			Cliente • Customer
4			Tecnico • Technician
			Cliente • Customer
5			Tecnico • Technician
			Cliente • Customer
6			Tecnico • Technician
			Cliente • Customer
7			Tecnico • Technician
			Cliente • Customer
8			Tecnico • Technician
			Cliente • Customer
9			Tecnico • Technician
			Cliente • Customer

INSTALLATORE
INSTALLER
INSTALLATEUR
INSTALLATEUR
INSTALATOR

DATA
DATE
DATE
DATUM
FECHA

Bft Spa
Via Lago di Vico, 44 ITALY
36015 Schio (VI)
T +39 0445 69 65 11
F +39 0445 69 65 22
→ www.bft-automation.com



SPAIN
BFT GROUP ITALIBERICA DE AUTOMATISMOS S.L.
08401 Granollers - (Barcelona)
www.bftautomatismos.com

FRANCE
AUTOMATISMES BFT FRANCE
69800 Saint Priest
www.bft-france.com

GERMANY
BFT TORANTRIEBSSYSTEME GmbH
90522 Oberasbach
www.bft-torantriebe.de

UNITED KINGDOM
BFT AUTOMATION UK LTD
Heaton Mersey, Stockport SK4 3GL
www.bft.co.uk

IRELAND
BFT AUTOMATION LTD
Dublin 12

BENELUX
BFT BENELUX SA
1400 Nivelles
www.bftbenelux.be

POLAND
BFT POLSKA SP. Z O.O.
05-091 ZABKI
www.bft.pl

CROATIA
BFT ADRIA D.O.O.
51218 Drazice (Rijeka)
www.bft.hr

PORTUGAL
BFT SA-COMERCIO DE AUTOMATISMOS E MATERIAL DE SEGURANCIA
3026-901 Coimbra
www.bftportugal.com

CZECH REPUBLIC
BFT CZ S.R.O.
Praha
www.bft.it

TURKEY
BFT OTOMATIK KAPI SISTEMELERI SANAY VE
Istanbul
www.bftotomasyon.com.tr

RUSSIA
BFT RUSSIA
111020 Moscow
www.bft rus.ru

AUSTRALIA
BFT AUTOMATION AUSTRALIA PTY LTD
Wetherill Park (Sydney)
www.bftaustralia.com.au

U.S.A.
BFT USA
Boca Raton
www.bft-usa.com

CHINA
BFT CHINA
Shanghai 200072
www.bft-china.cn

UAE
BFT Middle East FZCO
Dubai