

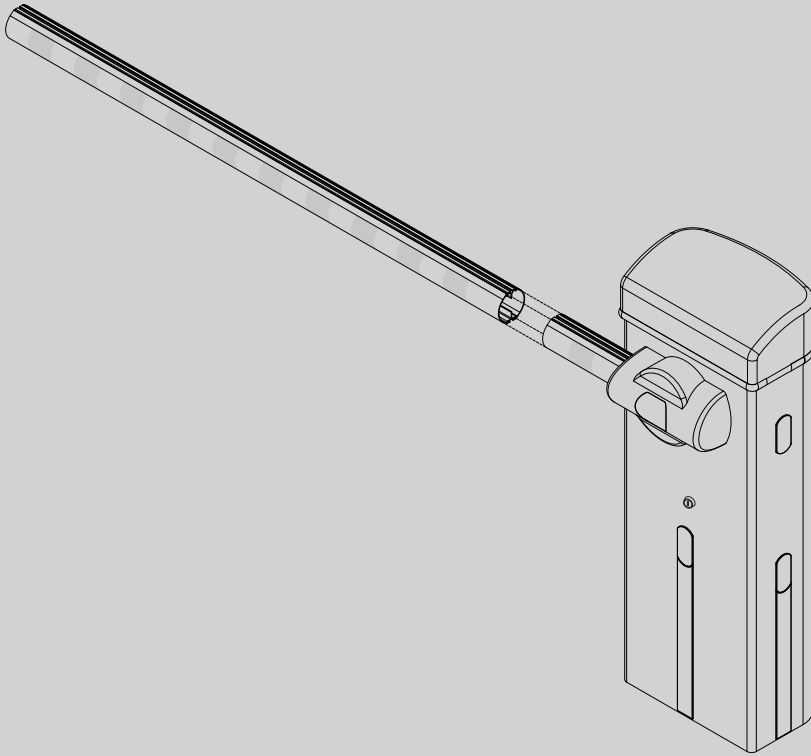

D612218 00100_01 27-03-15

AUTOMATISMO ELETTROMECCANICO PER BARRIERA VEICOLARE
ELECTROMECHANICAL CONTROL DEVICE FOR VEHICULAR BARRIERS
AUTOMATISME ELECTROMECHANIQUE POUR BARRIERE POUR VÉHICULES
ELEKTROMECHANISCHER ANTRIEB FÜR FAHRZEUGSCHRANKEN
AUTOMATISMOS ELECTROMECHANICOS PARA BARRERAS VEHICULAR
ELEKTROMECHANISCH AUTOMATISERINGSSYSTEEM VOOR SLAGBOOM



ISTRUZIONI D'USO E DI INSTALLAZIONE
INSTALLATION AND USER'S MANUAL
INSTRUCTIONS D'UTILISATION ET D'INSTALLATION
INSTALLATIONS-UND GEBRAUCHSANLEITUNG
INSTRUCCIONES DE USO Y DE INSTALACION
GEBRUIKS- EN INSTALLATIEAANWIJZINGEN

MICHELANGELO BT A 60
MICHELANGELO BT A 80

U-link



AZIENDA CON SISTEMA DI GESTIONE
INTEGRATO CERTIFICATO DA DNV
= UNI EN ISO 9001:2008 =
UNI EN ISO 14001:2004

Attenzione! Leggere attentamente le "Avvertenze" all'interno! **Caution!** Read "Warnings" inside carefully! **Attention!** Veuillez lire attentivement les Avertissements qui se trouvent à l'intérieur!
Achtung! Bitte lesen Sie aufmerksam die „Hinweise“ im Inneren! **¡Atención!** Leer atentamente las "Advertencias" en el interior! **Let op!** Lees de "Waarschuwingen" aan de binnenkant zorgvuldig!

www.torautomatic.hr

INSTALLAZIONE VELOCE-QUICK INSTALLATION-INSTALLATION RAPIDE
SCHNELLINSTALLATION-INSTALACIÓN RÁPIDA - SNELLE INSTALLATIE

D812218 00100_01

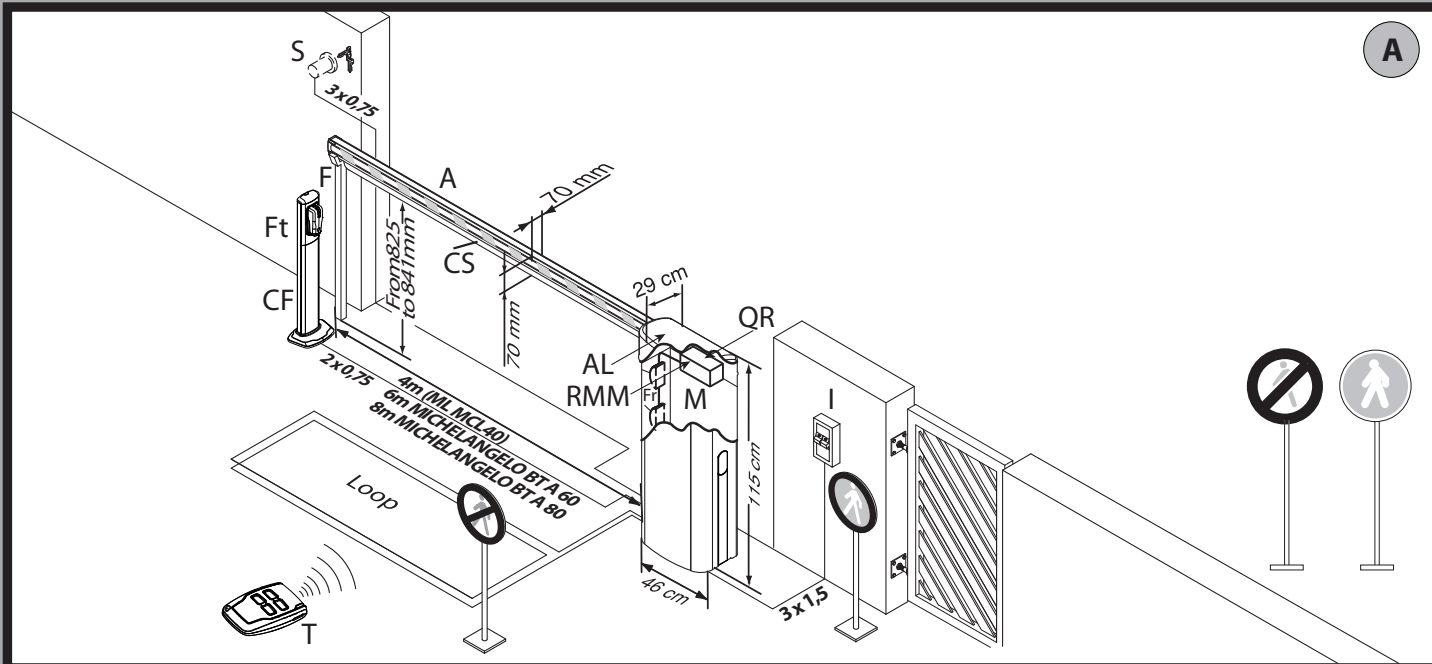

Con scavo di fondazione:
With foundation plate embedded in ground:
Avec tranchée de fondation:
Mit Fundamentgraben:
Con excavación de cimentación:
Met uitgraving:

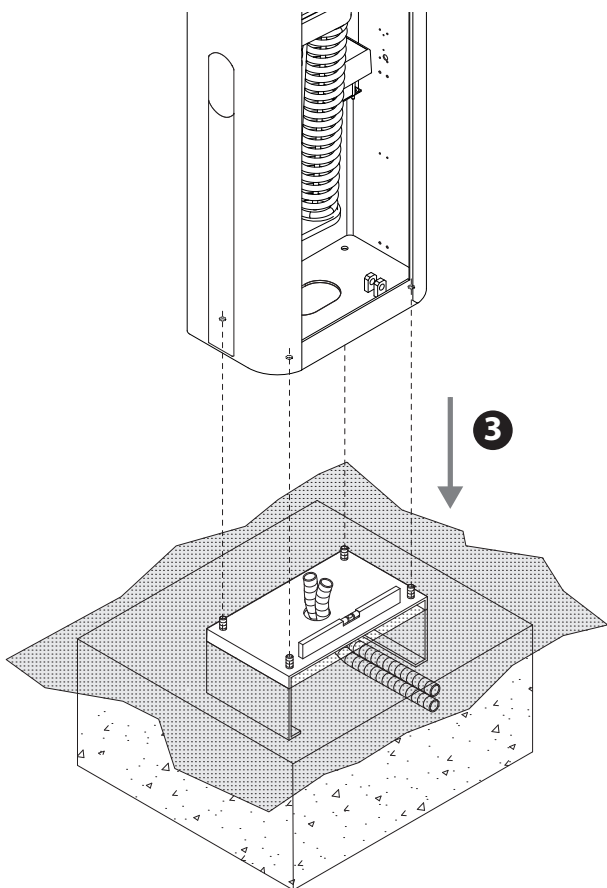
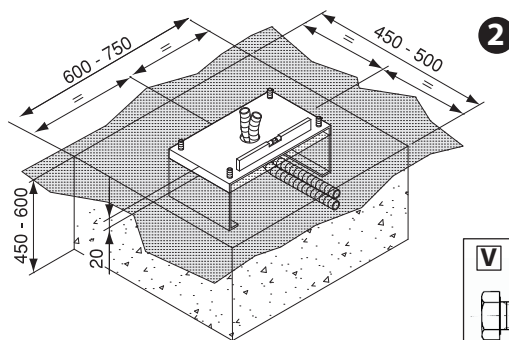
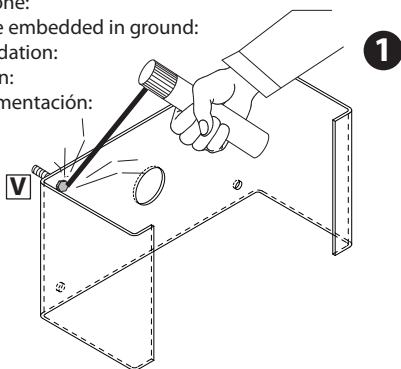

Con tiranti:
With anchor bolts:
Avec tirants:
Mit Ankerbolzen:
Con tirantes:
Met spankabels:

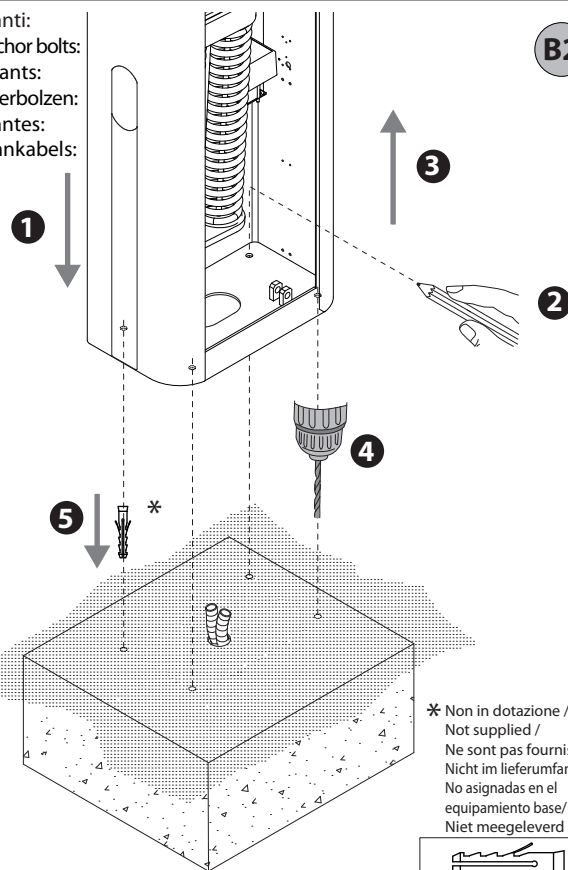

* Non in dotazione /
Not supplied /
Ne sont pas fournis /
Nicht im Lieferumfang /
No asignadas en el
equipamiento base/
Niet meegeleverd

Apertura e chiusura coperchio e portina, Opening and closing cover and door, Ouverture et fermeture du couvercle et portillon, Öffnung und Schließung Abdeckung und kleine Tür, Apertura y cierre de la tapa y de la portezuela, Opening en sluiting deksel en klepje.

C

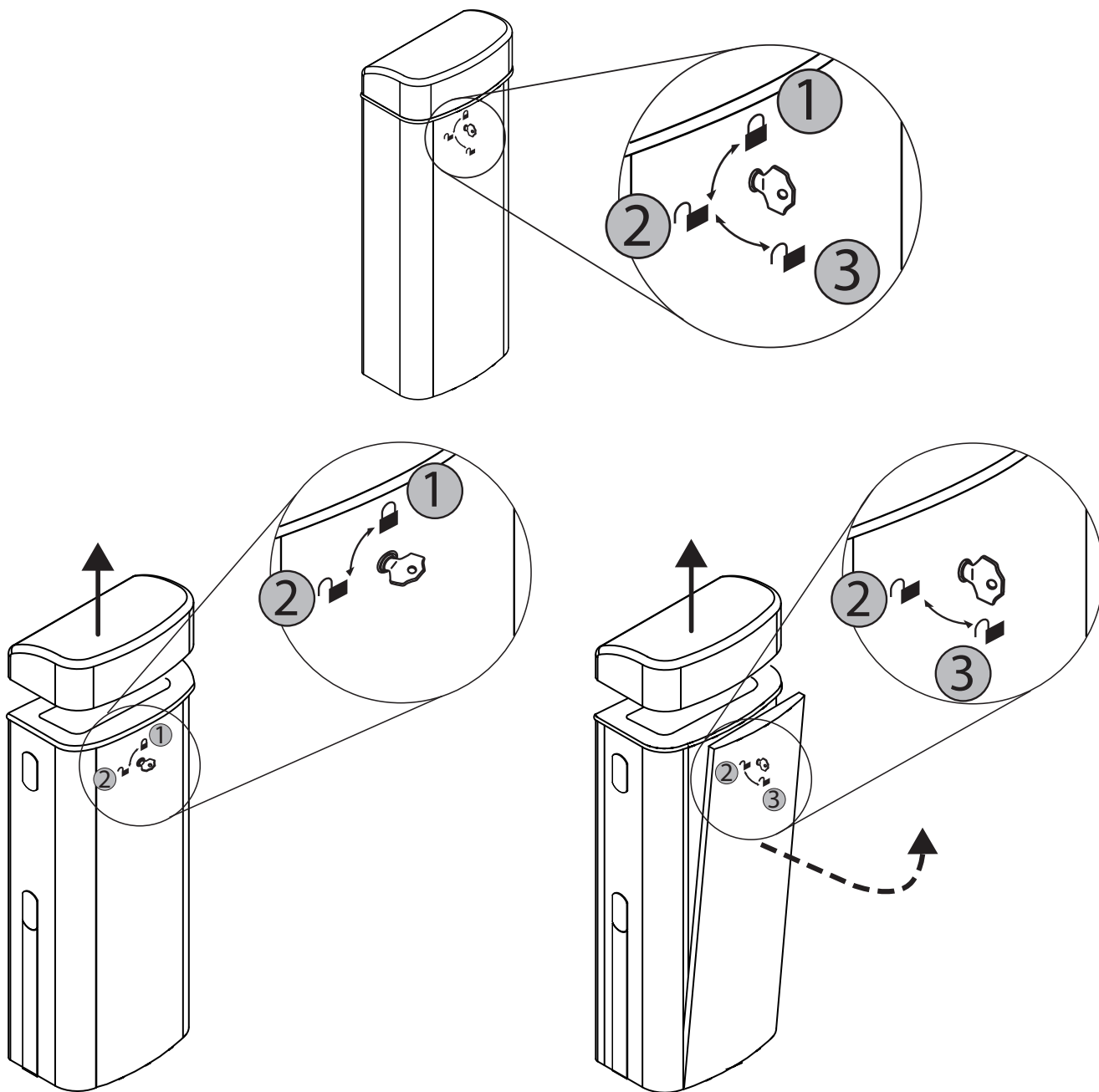

D

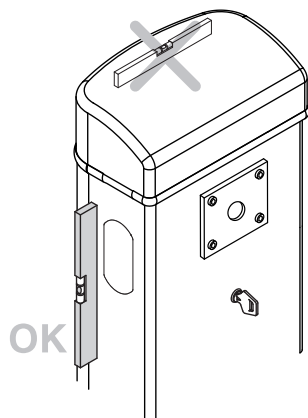

E

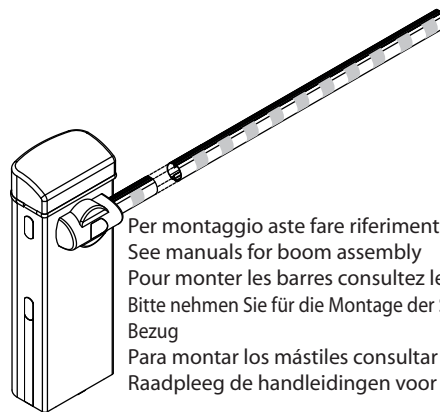

Per montaggio aste fare riferimento ai manuali
See manuals for boom assembly
Pour monter les barres consultez les manuels
Bitte nehmen Sie für die Montage der Stange auf die Handbücher
Para montar los mástiles consultar los manuales
Raadpleeg de handleidingen voor de montage van de bommen

Accessori MICHELANGELO: lunghezza utile asta e bilanciamento. / MICHELANGELO Accessories: working length of boom and balancing. / Accessoires MICHELANGELO: longueur utile de la barre et équilibrage. / MICHELANGELO Zubehör: Nutzlänge Schranke und Auswuchtung. / Accesorios MICHELANGELO: longitud útil mástil y balance. / Accessoires MICHELANGELO: nuttige lengte slagboom en balancerings.																							
SB			+ SB	+ SB	+ SB									+ SB	+ SB	+ SB							
PCA N (solo sopra l'asta)*1			+ PCA N	+ PCA N		+ PCA N	+ PCA N		+ PCA N	+ PCA N	+ PCA N	+ PCA N		+ PCA N	+ PCA N		+ PCA N	+ PCA N		+ PCA N	+ PCA N		
PCA N (solo sotto l'asta)*2									+ PCA N	+ PCA N									+ PCA N	+ PCA N			
KIT MCL LIGHT			+ LIGHT			+ LIGHT			+ LIGHT	+ LIGHT				+ LIGHT			+ LIGHT		+ LIGHT				
GA AQ AT / GAMA AQ AT			+ GA/ GAMA	+ GA/ GAMA	+ GA/ GAMA	+ GA/ GAMA	+ GA/ GAMA	+ GA/ GAMA	+ GA/ GAMA	+ GA/ GAMA	+ GA/ GAMA	+ GA/ GAMA	+ GA/ GAMA										
BIR						+ BIR	+ BIR	+ BIR									+ BIR	+ BIR	+ BIR				
ML MCL40 + AT704	A	MIN L		2,8	2,8	2,9	3,2	3,3	3,4	3,5	3,6	3,5	3,7	3,9	3	3	3,1	3,5	3,5	3,6	3,8	3,8	
		MAX L		3	3,1	3,1	3,4	3,5	3,6	3,7	3,9	3,8	3,9	4	3,2	3,2	3,3	3,7	3,8	3,9	4	4	
	B	MIN L	3,4	2,1	2,1	2,2	2,4	2,4	2,5	2,6	2,7	2,6	2,7	2,8	2,3	2,3	2,4	2,6	2,7	2,8	2,8	2,9	3
		MAX L	4	2,5	2,6	2,6	2,9	2,9	3	3,1	3,3	3,2	3,3	3,5	2,7	2,7	2,8	3,1	3,2	3,3	3,4	3,5	3,6
	C	MIN L	2,6	1,6	1,6	1,7	1,9	2	2	2,1	2,2	2,1	2,2	2,3	1,8	1,8	1,9	2,1	2,1	2,2	2,3	2,3	2,4
		MAX L	3,2	2,1	2,1	2,2	2,4	2,5	2,5	2,6	2,8	2,7	2,8	2,9	2,3	2,3	2,4	2,7	2,7	2,8	2,9	3	3,1
ML MCL40 + AQ6	A	MIN L		3	3,1	3,2	3,6	3,6	3,8	3,9					3,3	3,3	3,4	3,9	3,9				
		MAX L		3,3	3,3	3,4	3,8	3,9	4	4					3,5	3,5	3,7	4	4				
	B	MIN L	3,8	2,3	2,3	2,4	2,6	2,7	2,8	2,9	3,1	3	3,1	3,3	2,5	2,5	2,6	2,9	3	3,1	3,3	3,3	3,3
		MAX L	4	2,7	2,8	2,9	3,2	3,3	3,4	3,5	3,7	3,6	3,8	4	2,9	3	3,1	3,5	3,6	3,7	3,9	4	4
	C	MIN L	3	1,8	1,8	1,9	2,1	2,2	2,3	2,3	2,4	2,3	2,5	2,6	2	2	2,1	2,3	2,4	2,5	2,6	2,7	2,8
		MAX L	3,8	2,3	2,3	2,4	2,7	2,8	2,9	3	3,1	3	3,2	3,4	2,5	2,5	2,6	3	3	3,2	3,3	3,4	3,6
MCL 60 + AQ6	A	MIN L	5,3	4,2	4,3	4,4	4,9	5	5,4	5,3	5,4	5,4	5,5	5,6	4,5	4,6	4,7	5,3	5,4	5,4	5,5	5,6	5,7
		MAX L	6	4,7	4,8	4,9	5,5	5,6	5,9	6	6	6	6	6	5	5,1	5,2	5,9	6	6	6	6	6
	B	MIN L	4,8	3,2	3,2	3,3	3,9	4	4,3	4,2	4,4	4,3	4,4	4,5	3,6	3,7	3,8	4,3	4,4	4,5	4,4	4,5	4,8
		MAX L	6	4	4,1	4,2	4,9	4,9	5,3	5,3	5,5	5,5	5,5	5,5	4,4	4,4	4,5	5,3	5,3	5,5	5,5	5,6	5,9
MCL 60 + AT704 + AT502	A	MIN L	5,2				4,5	4,5	4,7	4,9	5,1	5,2	5,2	5,3				4,7	4,8	5	5,2	5,3	5,4
		MAX L	6				5,2	5,3	5,5	5,7	5,9	5,9	6	6				5,5	5,6	5,8	6	6	6
	B	MIN L	3,8				2,8	2,9	3,1	3,1	3,4	3,4	3,5	3,6				3,3	3,4	4,2	3,8	3,8	3,9
		MAX L	5,1				4,1	4,2	4,5	4,5	5	4,9	5	5,1				4,5	4,6	5	5,1	5,1	5,1
MCL 60 + AT706	A	MIN L	5,3	3,6	3,7	3,8	4,2	4,3	4,4	4,5	4,7	4,6	4,8	5	3,8	3,9	4	4,4	4,5	4,6	4,8	4,9	5,1
		MAX L	6	4,1	4,2	4,3	4,7	4,8	4,9	5,1	5,3	5,2	5,4	5,6	4,3	4,4	4,5	4,9	5	5,2	5,4	5,5	5,7
	B	MIN L	4,2	2,9	2,9	3	3,3	3,3	3,5	3,6	3,7	3,6	3,8	3,9	3	3,1	3,2	3,5	3,6	3,7	3,8	3,9	4
		MAX L	5,3	3,6	3,7	3,8	4,2	4,2	4,4	4,5	4,7	4,6	4,8	5	3,8	3,9	4	4,4	4,5	4,6	4,8	4,9	5,1

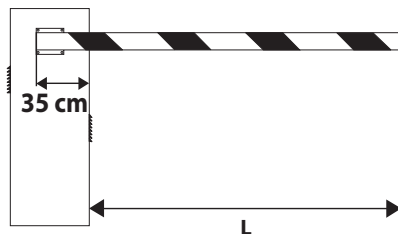

L: Lunghezza utile asta.
L: Working boom length.
L: Longueur utile de la barre.
L: Nutzlänge der Schranke.
L: Longitud útil mástil.
L: Nuttige lengte slagboom.

***1**
 (above boom only)
 (uniquement sur la barre)
 (nur über der Schranke)
 (sólo sobre el mástil)
 (alleen boven de slagboom)

***2**
 (below boom only)
 (uniquement sous la barre)
 (nur unter der Schranke)
 (sólo debajo el mástil)
 (alleen onder de slagboom)

Cablaggio Trasformatore, Transformer wiring, Câblage du transformateur, Verkabeling Transformator, Cableado Transformador, Bekabeling Transformator.

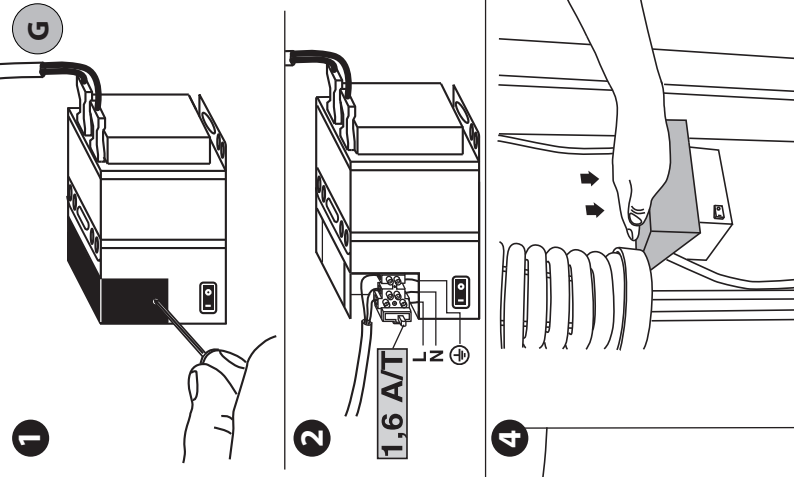
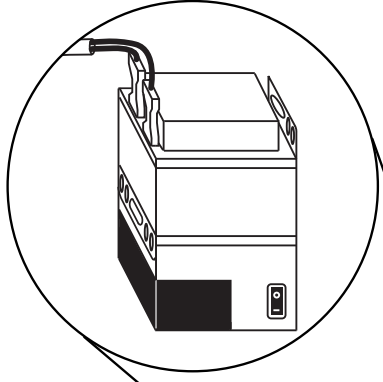
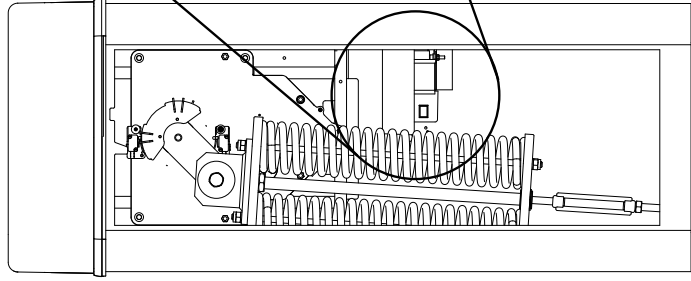

H

Connettore scheda opzionale / Optional board connector,
Connecteur carte facultative / Steckverbinder Zusatzkarte,
Conector de la tarjeta opcional / Conector optionale kaart.

Display + tasti programmazione / Display plus programming keys,
Afficheur et touches de programmation / Display und Programmierungstasten,
Pantalla mas botones de programacion / Display meerdere toetsen programmeur.

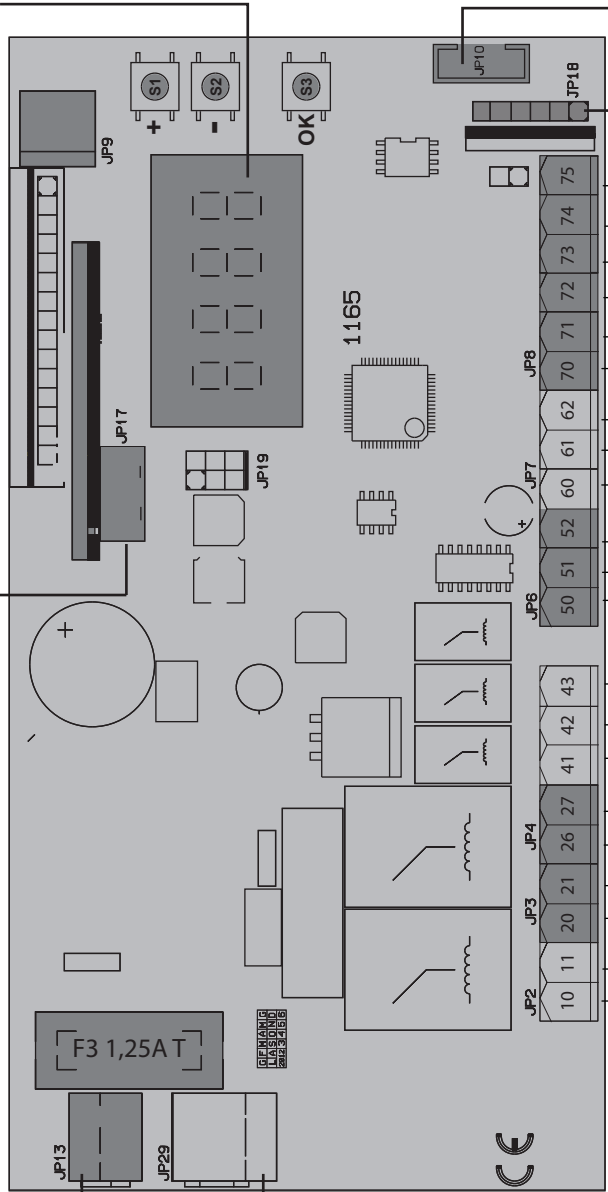

Sec transf
Sec transf
2. Transf
Seg transf
Tweede transf
Sec trasf
Ponte raddrizzatore / Rectifier bridge
Pont redresseur / Gleichrichterbrücke
Ponte raddrizzatore / Rectifier bridge

Connettore programatore palmare,
Palmtop programmer connector,
Connecteur programmeur de poche,
Steckverbinder Palmtop-Programmierer,
Conector del programador de bolsillo,
Connector programmeerbare palmtop.

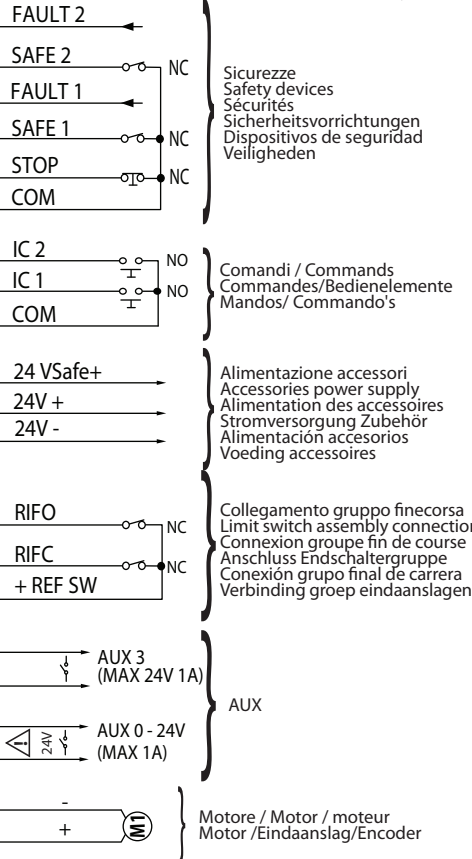

Connettore encoder
Encoder connector
Connecteur encodeur
Steckverbinding Encoder
Conector Encoder
Connector encoder

Sicurezze
Safety devices
Sécurité
Sicherheitsvorrichtungen
Dispositivos de seguridad
Veiligheden

Comandi / Commands
Commandes/Bedienelemente
Mandos/ Commando's

Alimentazione accessori
Accessories power supply
Alimentation des accessoires
Stromversorgung Zubehör
Alimentación accesorios
Voeding accessoires

Collegamento gruppo finecorsa
Limit switch assembly connection
Connexion groupe fin de course
Anschluss Endschaltergruppe
Conexión grupo final de carrera
Verbinding groep eindaanslagen

AUX

Motore / Motor / moteur
Motor /Eindaanslag/Encoder

I

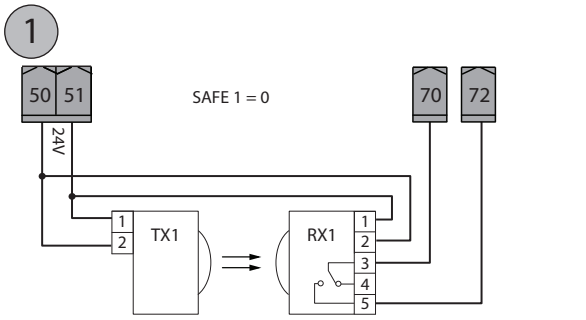

Collegamento di 1 coppia di fotocellule non verificate,
 Connection of 1 pair of non-tested photocells,
 Connexion 1 paire photocellules non vérifiées,
 Anschluss von einem Paar nicht überprüften Fotozellen,
 Conexión de 1 par fotocélulas no comprobadas,
 Aansluiting van 1 paar fotocellen anders dan "trusted device".

AUX 3 = 1

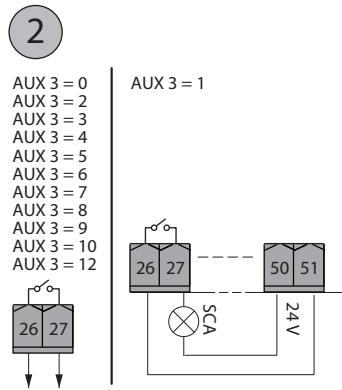

- AUX 3 = 0
- AUX 3 = 2
- AUX 3 = 3
- AUX 3 = 4
- AUX 3 = 5
- AUX 3 = 6
- AUX 3 = 7
- AUX 3 = 8
- AUX 3 = 9
- AUX 3 = 10
- AUX 3 = 12

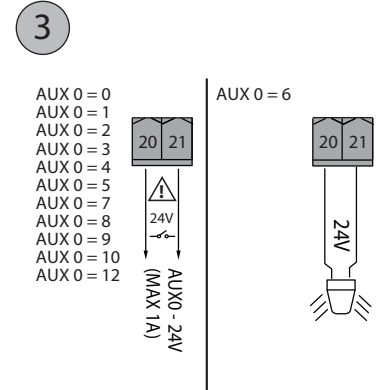

- AUX 0 = 0
- AUX 0 = 1
- AUX 0 = 2
- AUX 0 = 3
- AUX 0 = 4
- AUX 0 = 5
- AUX 0 = 7
- AUX 0 = 8
- AUX 0 = 9
- AUX 0 = 10
- AUX 0 = 12

4 Connessione A Sistema Gestione Parcheggi, Connection To Car-park Management System, Connexion Au Système De Gestion Des Parkings, Anschluss An Das Parkplatzbewirtschaftungssystem, Conexión Al Sistema De Gestion De Aparcamientos, Erbinding Met Beheersysteem parkeerplaatsen

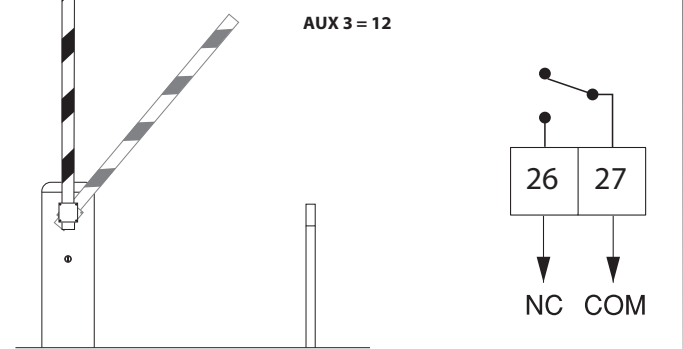
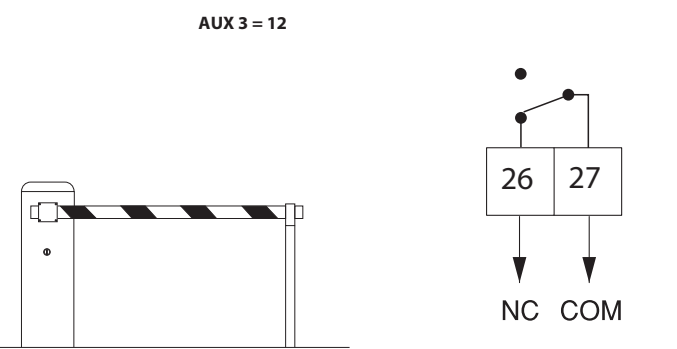

L

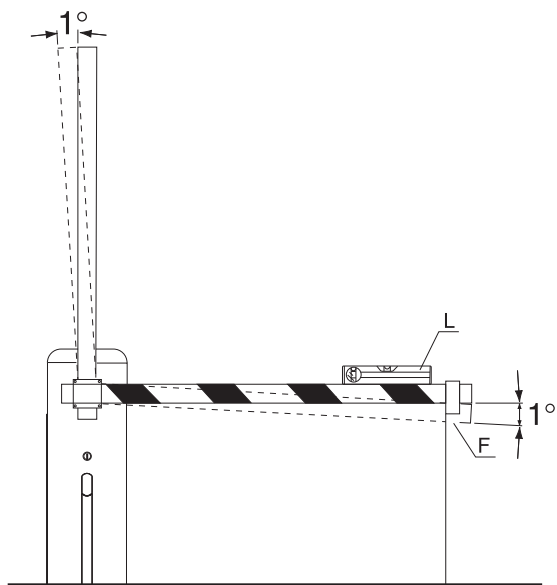

SIMPLIFIED MENU (FIG. 1)

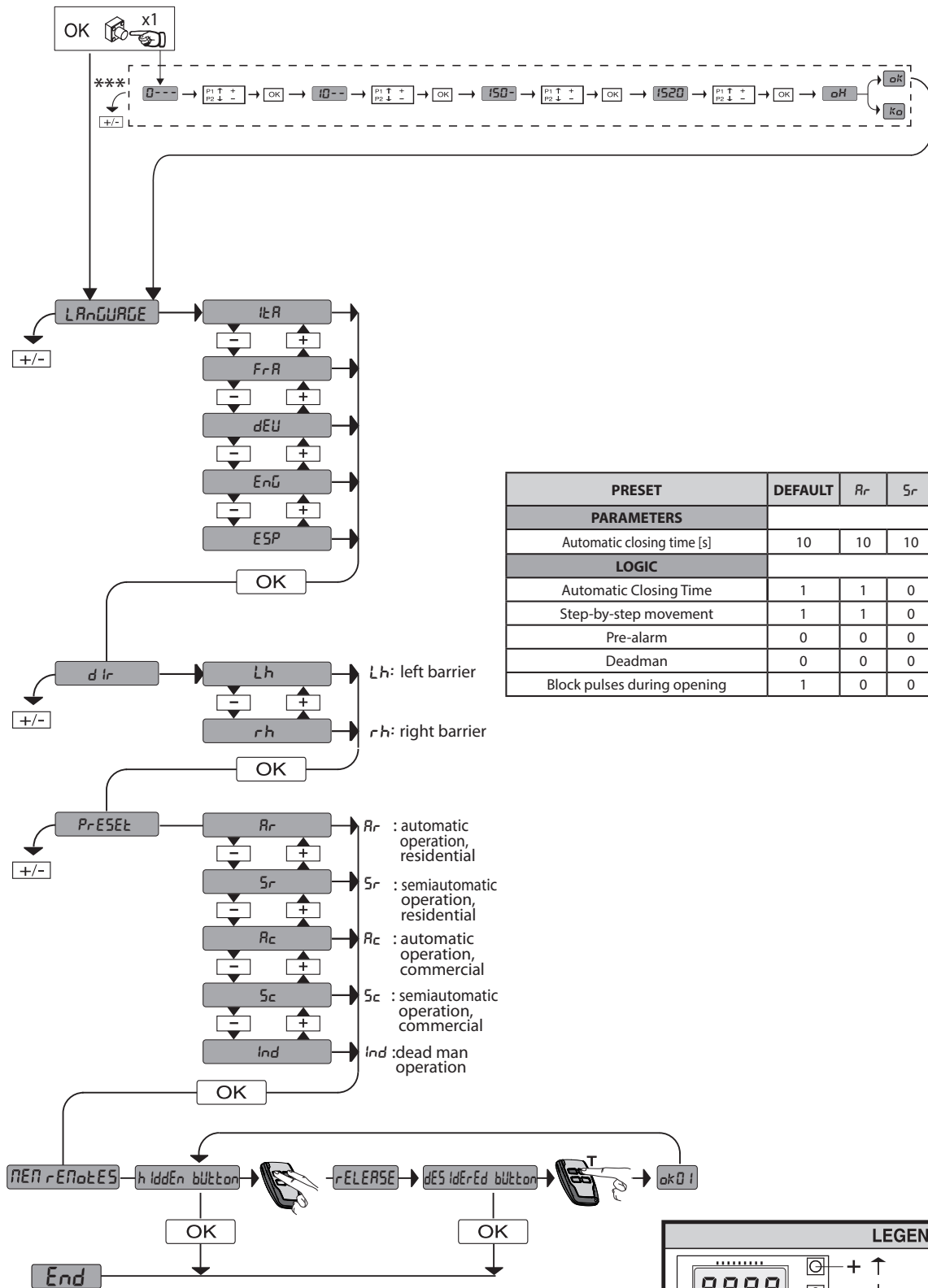

PRESET	DEFAULT	Rr	Sr	Rc	Sc	ind
PARAMETERS						
Automatic closing time [s]	10	10	10	5	5	5
LOGIC						
Automatic Closing Time	1	1	0	1	0	0
Step-by-step movement	1	1	0	1	0	0
Pre-alarm	0	0	0	1	1	0
Deadman	0	0	0	0	0	1
Block pulses during opening	1	0	0	1	1	0

LEGENDA

.....
 8888

+ ↑
 - ↓
 OK ↵

Scroll up
 Scroll down
 Confirm/Switch on display

+

-

Exit Menü

Montaggio Asta Destra, Assembly of right boom, Montage de la barre droite,
Rechte Montage der Stange, Montaje mástil derecho, Montage rechterstang.

AA

D812218 00100_01

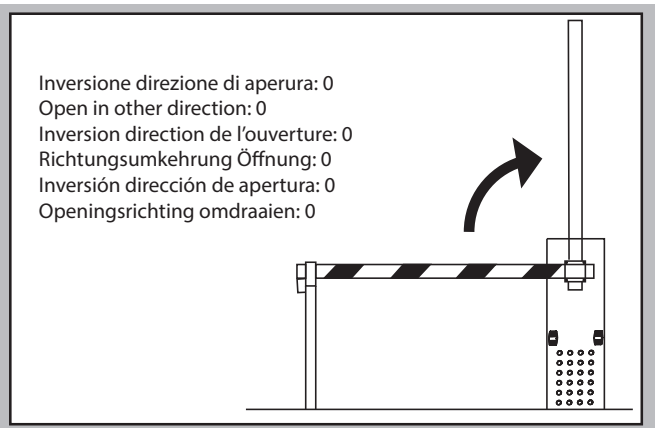
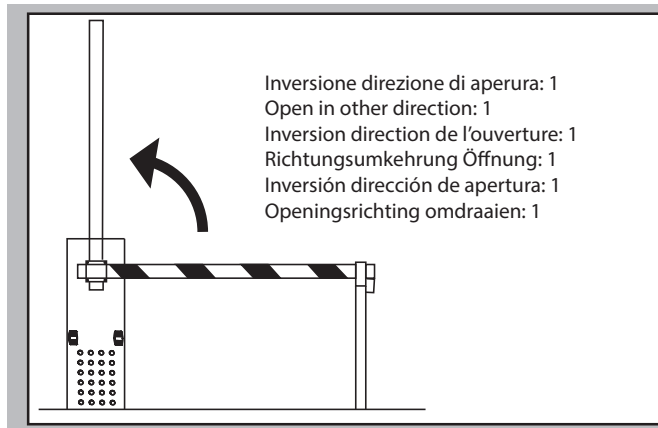

Assicurarsi che la molla non sia in tensione, e l'asta non sia montata.
Make sure the spring is not under tension and the boom is not fitted.
Vérifiez si le ressort n'est pas en tension et si la tige n'est pas montée.
Sicherstellen, dass die Feder nicht gespannt und die Stange nicht montiert ist.
Asegurarse de que el muelle no esté tensado y de que el mástil no esté montado.
Controleren of de veer niet onder spanning staat, en de stang niet gemonteerd is.

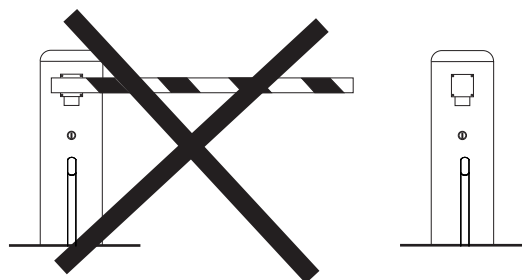

Smontare il gruppo molla.
Remove the spring assembly.
Démonter le groupe ressort.
Die Feder-Baugruppe ausbauen.
Desmontar el grupo muelle.
De groep veer demonteren.

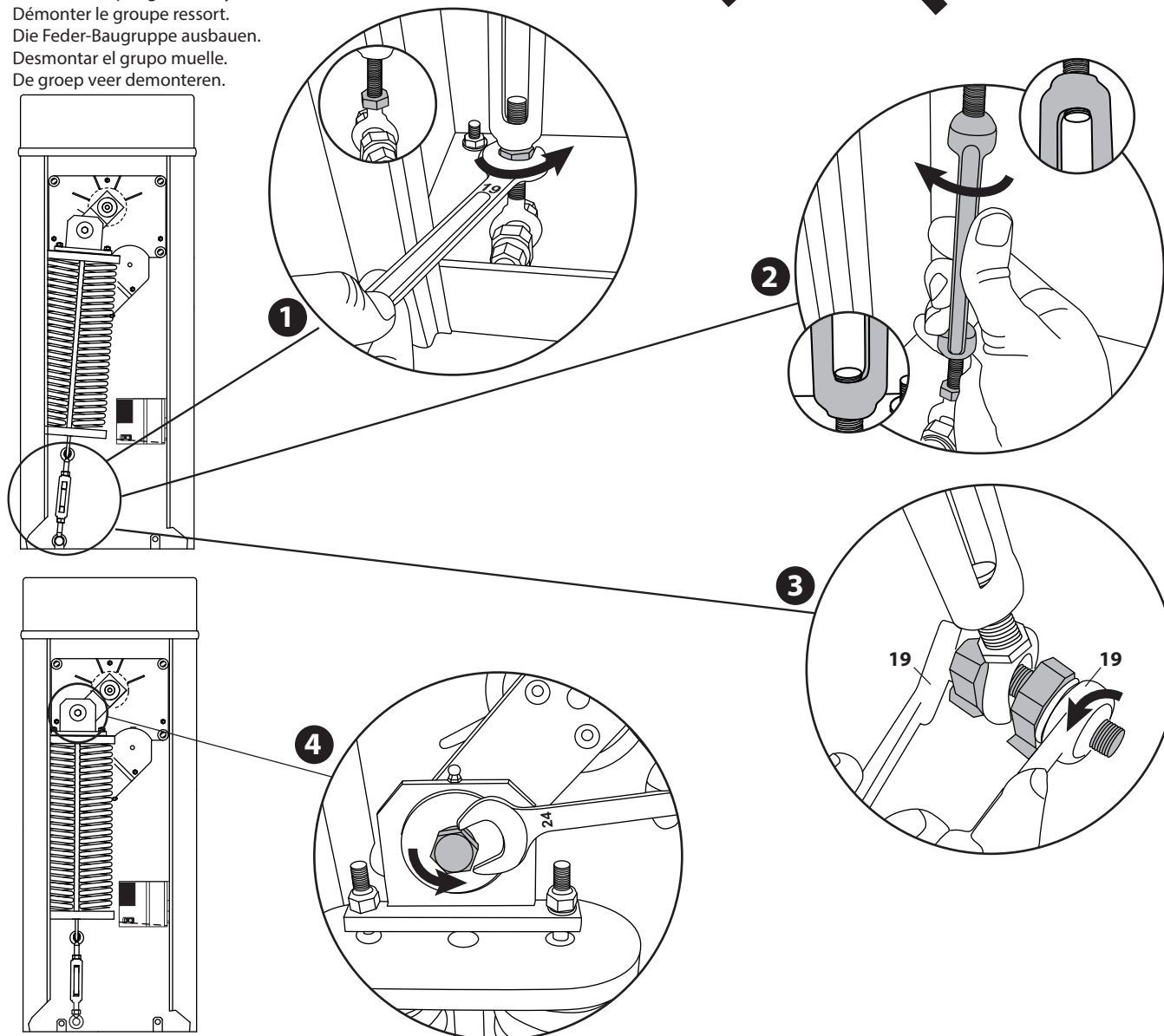

Rimontare il gruppo molla a destra, Refit the right-hand spring assembly,
Remontez le groupe ressort à droite, Die Baugruppe neu montieren, Feder rechts,
Volver a montar el grupo muelle a la derecha, De veergroep opnieuw rechts monteren.

AB

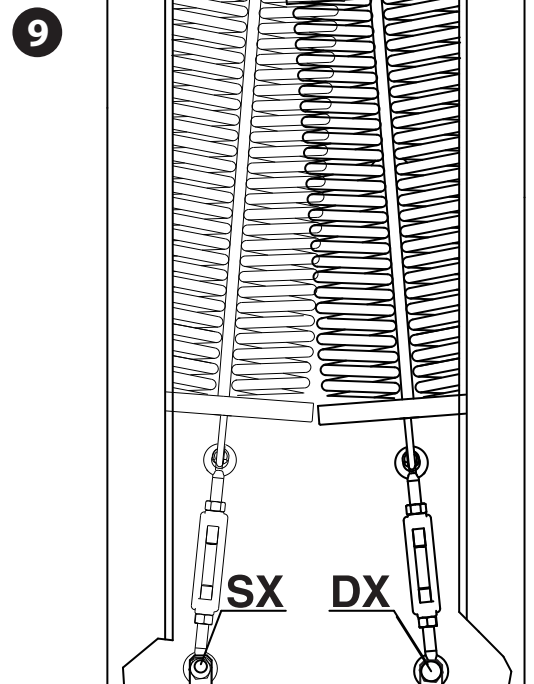
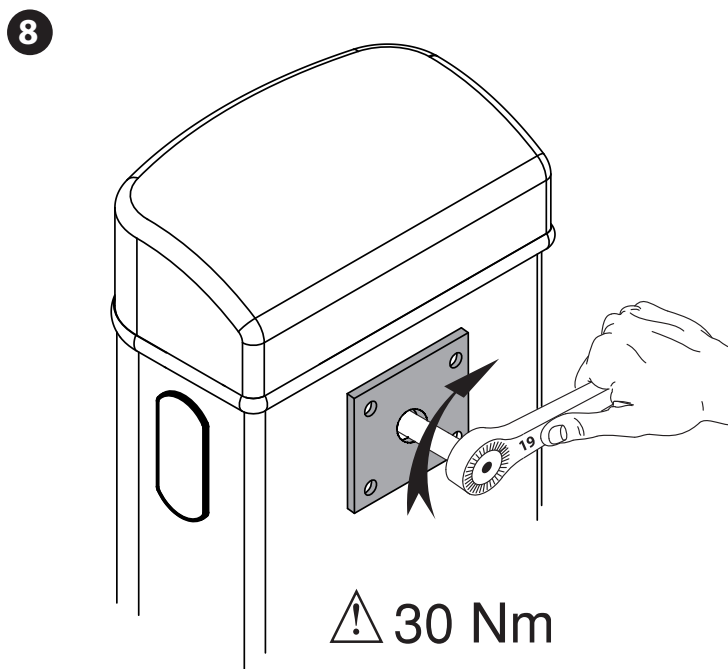
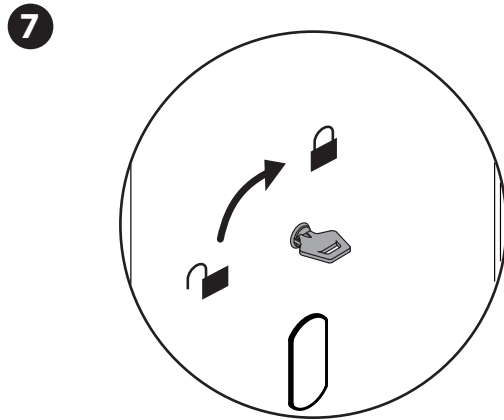
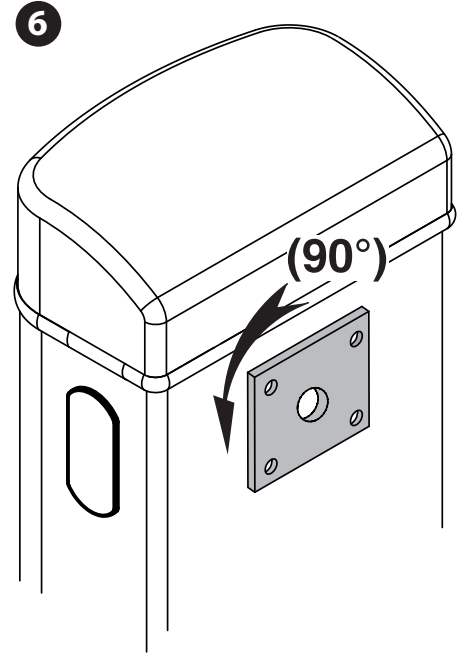
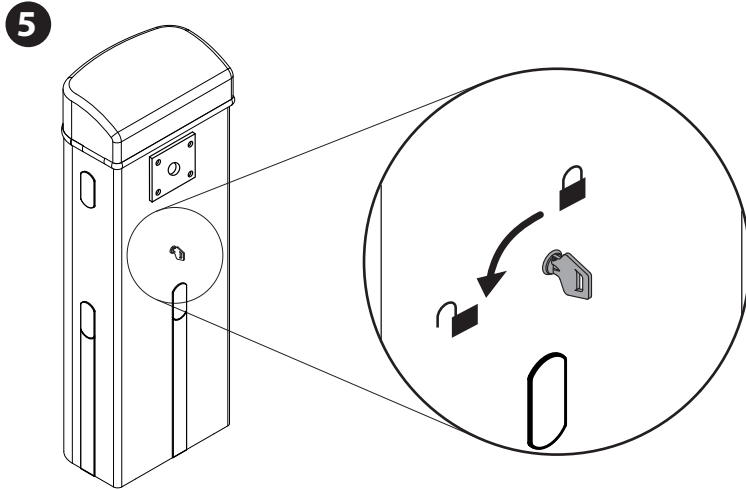

Assicurarsi che la molla non sia in tensione, e l'asta non sia montata.
 Make sure the spring is not under tension and the boom is not fitted.
 Vérifiez si le ressort n'est pas en tension et si la tige n'est pas montée.
 Sicherstellen, dass die Feder nicht gespannt und die Stange nicht montiert ist.
 Asegurarse de que el muelle no esté tensado y de que el mástil no esté montado.
 Controleren of de veer niet onder spanning staat, en de stang niet gemonteerd is.

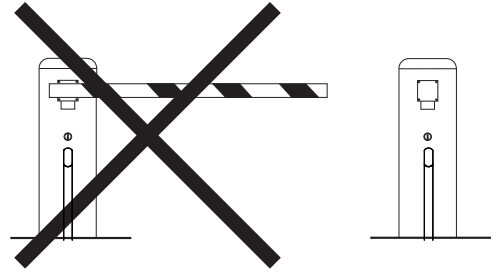

1

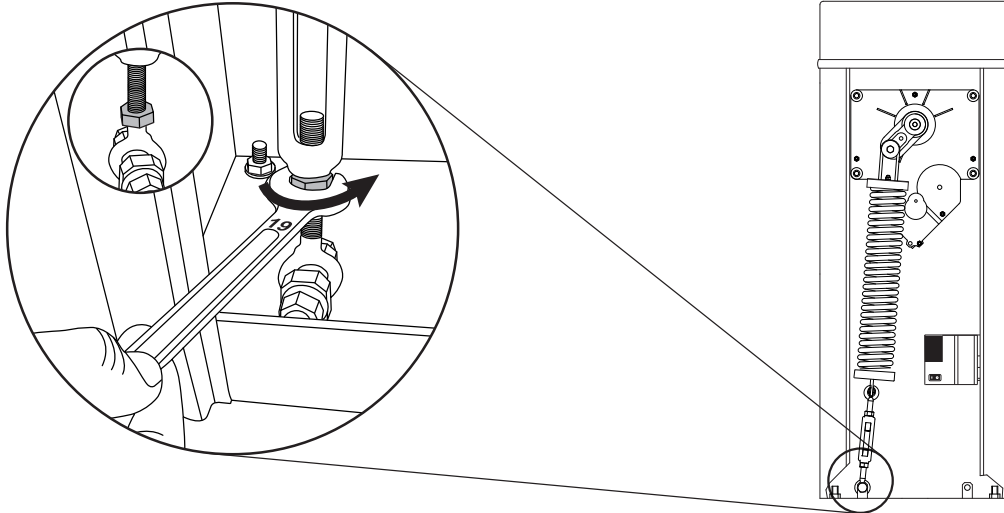

2

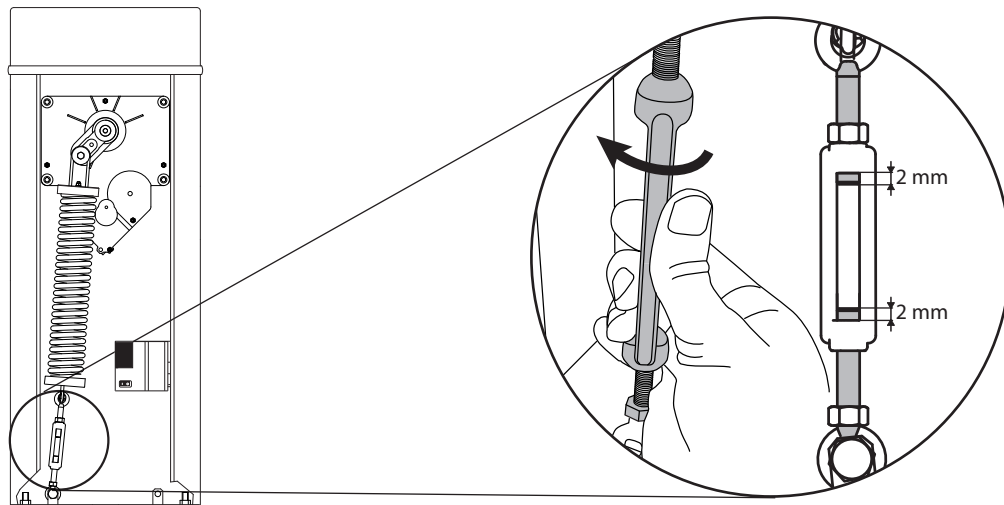

3

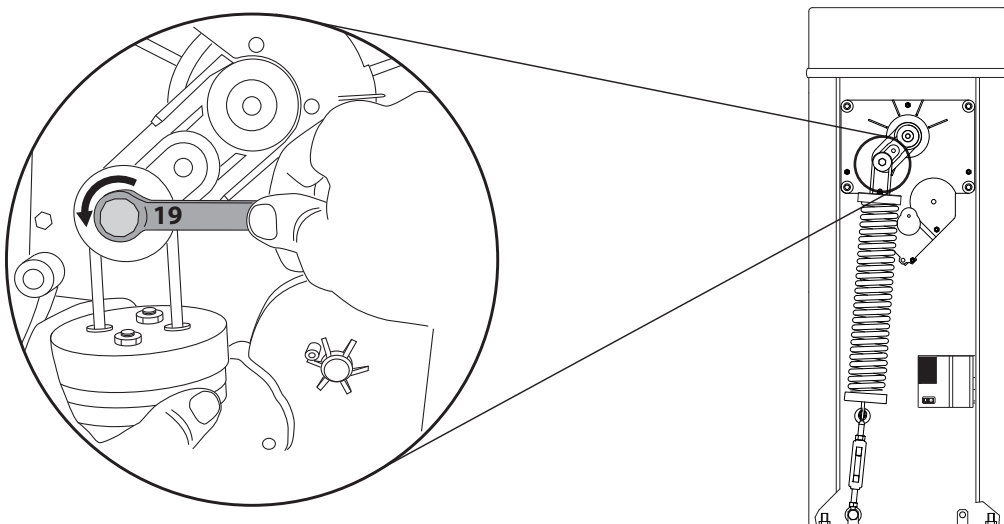

AD

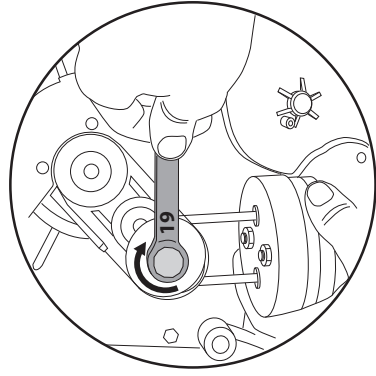

4

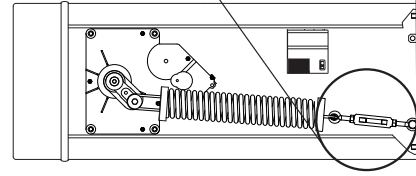
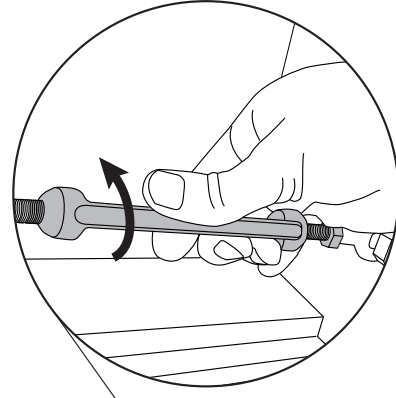
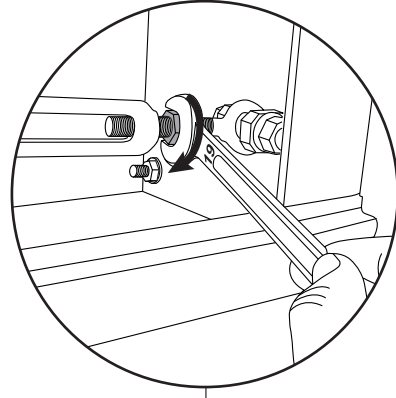

5

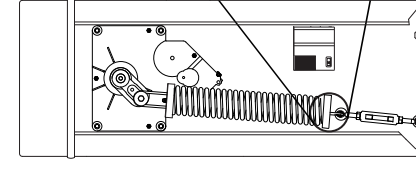
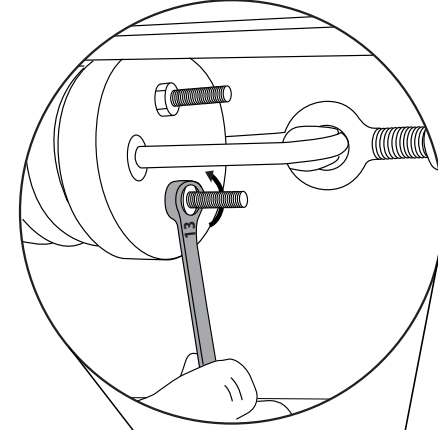
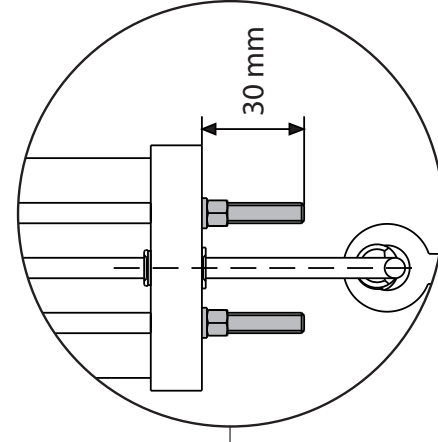

6

MONTAGGIO LAMPEGGIANTE, FITTING THE FLASHING LIGHT, MONTAGE DU CLIGNOTANT, MONTAGE DER BLINKLEUCHTE, MONTAJE DEL INDICADOR PARPADEANTE, MONTAGE FOTOCCEL

AE

Per l'installazione del lampeggiante fare riferimento ai manuali del lampeggiante
 See the flashing light's manual for instructions on installing the flashing light
 Pour monter le clignotant consultez le manuel du clignotant
 Bitte nehmen Sie für die Installation der Blinkleuchte auf das Handbuch der Blinkleuchte Bezug
 Para instalar el indicador parpadeante consultar el manual del mismo
 Raadpleeg de handleiding van het zwaailicht voor de installatie van het zwaailicht

ATTENZIONE! togliere il coperchietto A
PLEASE NOTE! Remove cover A
ATTENTION ! Retirez le couvercle A
ACHTUNG! Entfernen Sie die Abdeckung A
¡ATENCIÓN! Quitar la tapa A
OPGELET! Demonteer het klepje A

ATTENZIONE! fissare il lampeggiante alla barriera con la vite (V1)
PLEASE NOTE! Fasten the flashing light on the barrier using the screw (V1)
ATTENTION ! Fixez le clignotant sur la barrière avec la vis (V1)
ACHTUNG! Befestigen Sie die Blinkleuchte mit der Schraube (V1) an der Schranke
¡ATENCIÓN! Fijar el indicador parpadeante a la barrea con el tornillo (V1)
OPGELET! Bevestig het zwaailicht met de schroef (V1) aan de slagboom

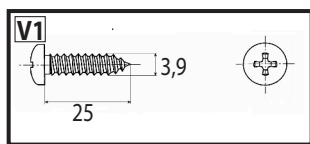

Installazione lampeggiante
 Installing the flashing light
 Installation du clignotant
 Installation der Blinkleuchte
 Instalación del indicador parpadeante
 Installatie zwaailicht

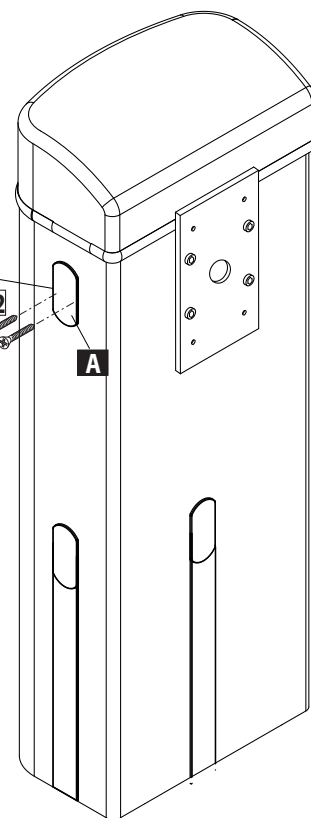

MONTAGGIO FOTOCELLULA, FITTING THE PHOTOCELL , MONTAGE DE LA PHOTOCELLULE, MONTAGE DER FOTOZELLE, MONTAJE DE LA FOTOCÉLULA, MONTAGE FOTOCCEL

AF

Per l'installazione della fotocellula e della fotocellula con supporto colonnina fare riferimento ai manuali delle fotocellule e ai manuali supporto colonnina
 See the photocell's manuals and post mount's manuals for instructions on installing the photocell and photocell with post mount
 Pour monter la photocellule et la photocellule avec colonnette de support consultez le manuel des photocellules et le manuel de la colonnette de support
 Bitte nehmen Sie für die Installation der Fotozelle und der Fotozelle mit Säulenhaltung auf das Handbuch der Fotozellen und auf das Handbuch der Säulenhaltung Bezug
 Para instalar la fotocélula y la fotocélula con soporte columna consultar el manual de las fotocélulas y el manual del soporte columna
 Raadpleeg de handleiding van de fotocellen en de handleiding van de steunpilaar voor de montage van de fotocel en de fotocel met steunpilaar

ATTENZIONE! togliere il coperchietto A, B o C per installare la fotocellula o il supporto colonnina
Please note! Remove cover A, B or C to install the photocell or post mount
Attention ! Retirez le couvercle A, B ou C pour monter la photocellule ou la colonnette de support
Achtung! Entfernen Sie die Abdeckung A, B oder C für die Installation der Fotozelle oder der Säulenhaltung
¡Atención! Quitar la tapa A, B o C para instalar la fotocélula o el soporte columna
Opgelet! Demonteer het klepje A, B of C voor de installatie van de fotocel of de steunpilaar

ATTENZIONE! fissare la fotocellula alla barriera con la vite qui illustrata (V2)
PLEASE NOTE! Fasten the photocell on the barrier using the screw (V2)
ATTENTION ! Fixez la photocellule sur la barrière avec la vis (V2)
ACHTUNG! Befestigen Sie die Fotozelle mit der Schraube (V2) an der Schranke
¡ATENCIÓN! Fijar la fotocélula a la barrea con el tornillo (V2)
OPGELET! Bevestig de fotocel met de schroef (V2) aan de slagboom

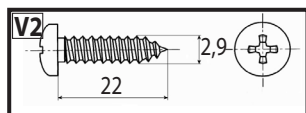

Installazione fotocellula
 Installing the photocells
 Montage des photocellules
 Installation der Fotozelle
 Instalación fotocélulas
 Installatie fotocellen

Installazione fotocellula con relativo supporto
 Installing the photocell with post mount
 Montage de la photocellule avec colonnette de support
 Installation der Fotozelle mit Säulenhaltung
 Instalación fotocélula con soporte columna
 Installatie fotocel met steunpilaar

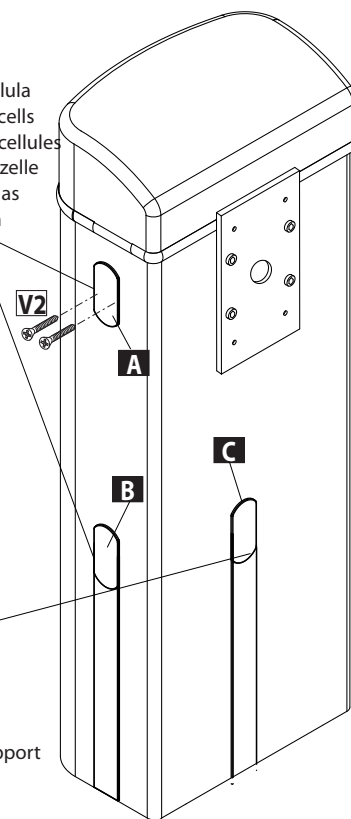

Montaggio rilevatore di masse metalliche, Fitting the metal object detector, Montage du détecteur de masses métalliques, Montage des Metallmassenmelders, Montaje del detector de masas metálicas, Montage detector metalen massa's

AG

ITALIANO

ENGLISH

FRANÇAIS

DEUTSCH

ESPAÑOL

NEDERLANDS

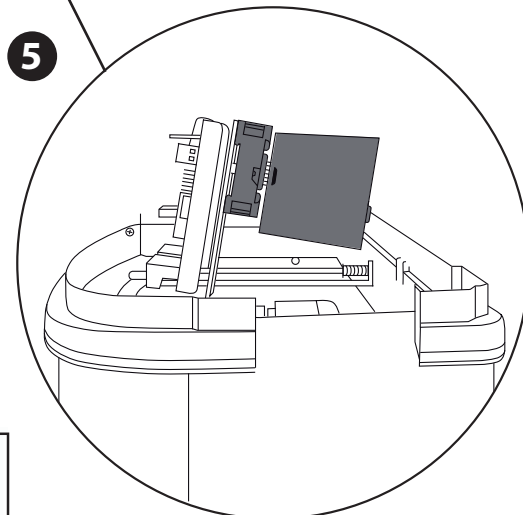
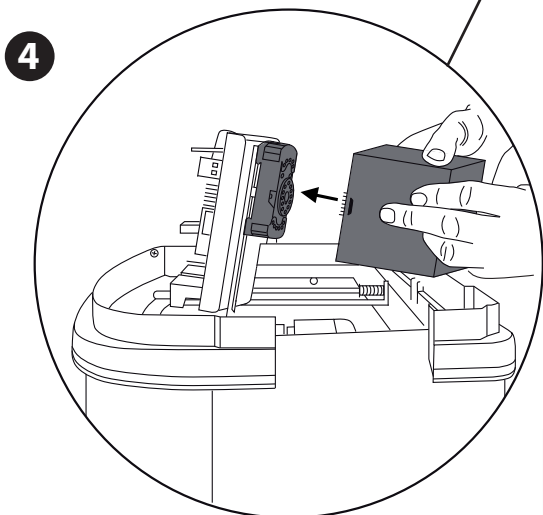
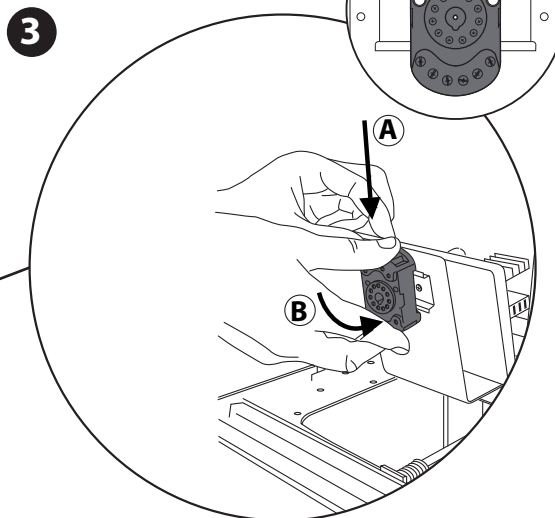
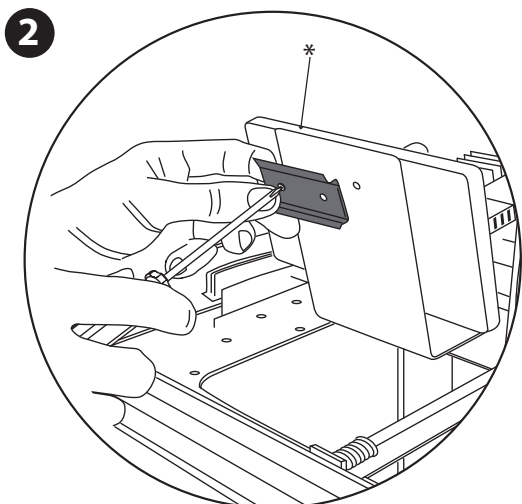
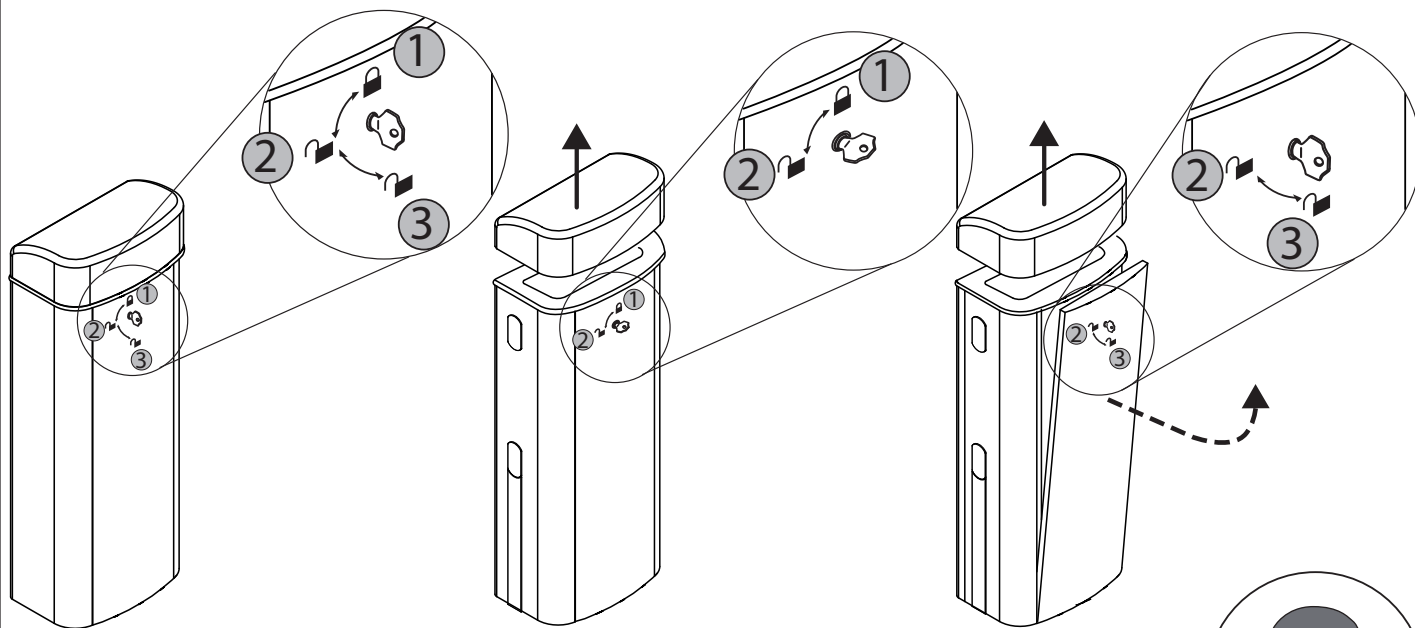

* Non in dotazione /
Not supplied / Ne sont pas fournis /
Nicht im Lieferumfang /
No asignadas en el equipamiento base /
Niet meegeleverd

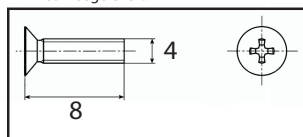

M

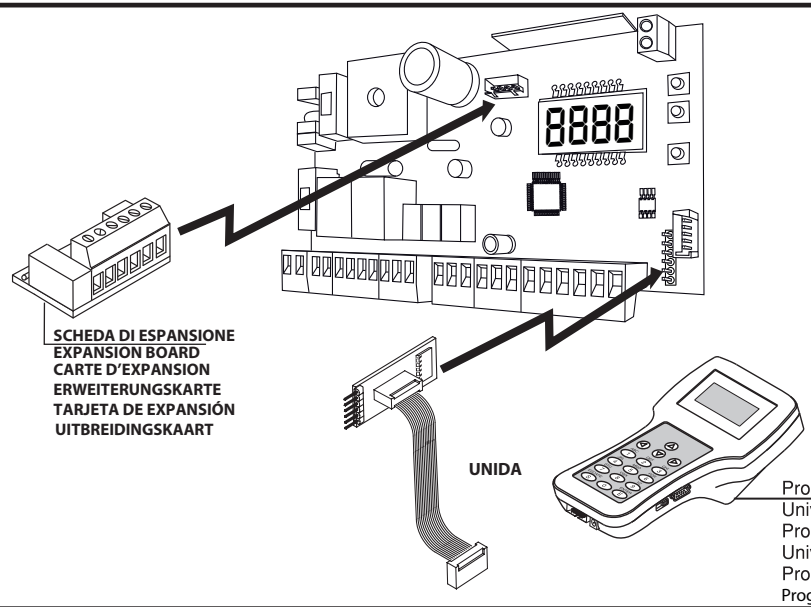

SCHEDA DI ESPANSIONE
EXPANSION BOARD
CARTE D'EXPANSION
ERWEITERUNGSKARTE
TARJETA DE EXPANSIÓN
UITBREIDINGSKAART

UNIDA

Programmatore palmare universale
Universal palmtop programmer
Programmeur de poche universel
Universellen Palmtop-Programmier
Programador de bolsillo universal
Programmeerbare Universele Palmtop

indir₂₀=0
Addr₅₅=0
Addr_{55E}=0
Addr_{55E}=0
dir_{Ecc Ion}=0

Podo_{5E} ir_{LE}=3
SE_{IRL} Pod_E=3
Pod_E SE_{IE}=3
SE_{IELLE} Pod_{US}=3
Podo_{5E} ir_A=3

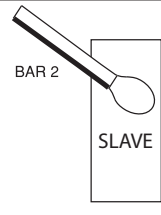
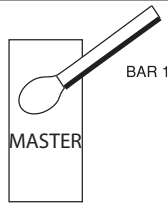

indir₂₀=0
Addr₅₅=0
Addr_{55E}=0
Addr_{55E}=0
dir_{Ecc Ion}=0

Podo_{5E} ir_{LE}=2
SE_{IRL} Pod_E=2
Pod_E SE_{IE}=2
SE_{IELLE} Pod_{US}=2
Podo_{5E} ir_A=2

N

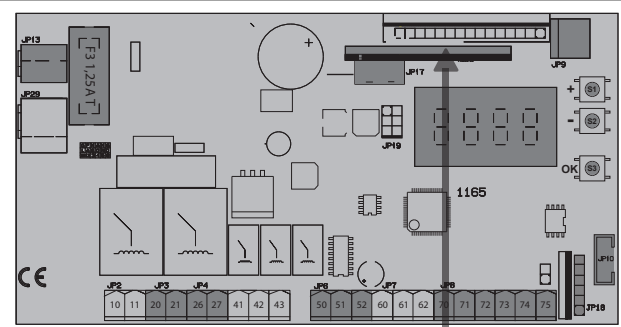
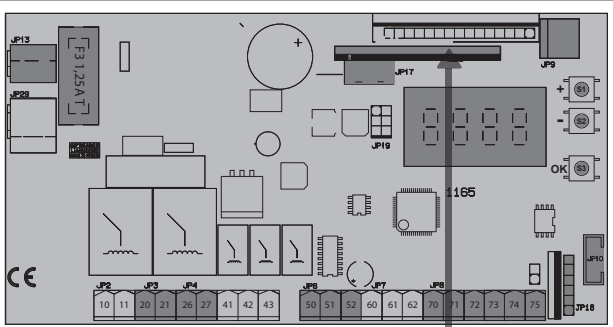

MAX 250m

B EBA U-LINK 485

B EBA U-LINK 485

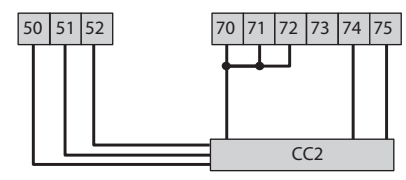
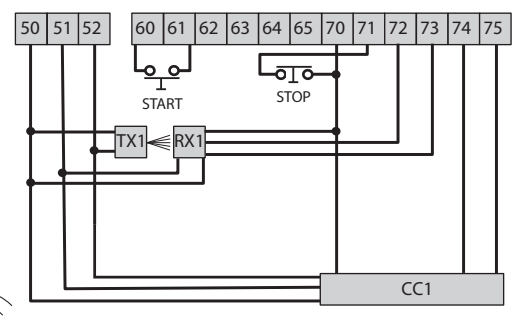

SAFE 1 = 1
SAFE 2 = 7

SAFE 2 = 7



PER IL COLLEGAMENTO DI PIÙ FOTOCELLULE FARE RIFERIMENTO ALLA FIG. P - TO CONNECT SEVERAL PHOTOCELLS, REFER TO FIG. P
 * POUR BRANCHER PLUSIEURS PHOTOCÉLULES CONSULTEZ LA FIG. P - BITTE NEHMEN SIE FÜR DEN ANSCHLUSS MEHRERER FOTOZELLEN AUF FIG. P BEZUG.
 PARA LA CONEXIÓN DE VARIAS FOTOCÉLULAS CONSULTAR LA FIG. P - VOOR HET VERBINDEN VAN MEERDERE FOTOCELLEN ZIE FIG. P

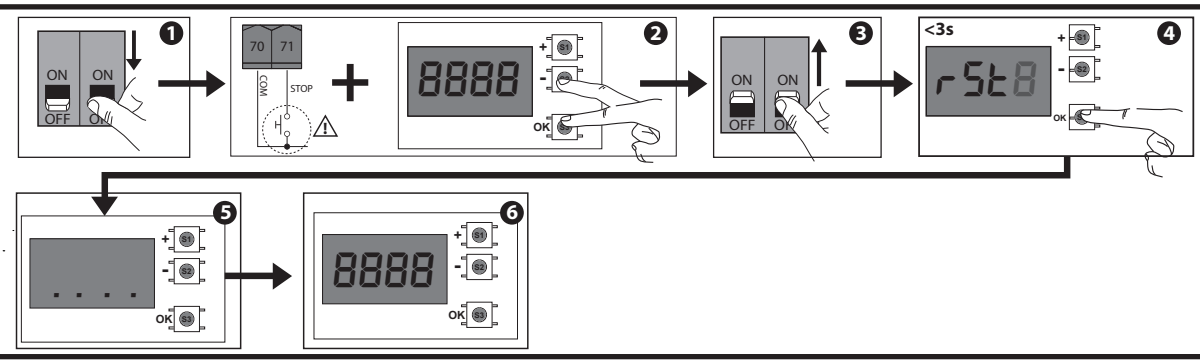

O

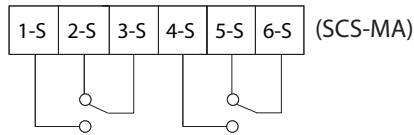
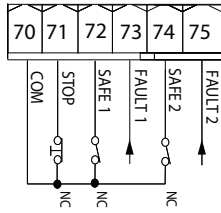
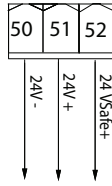

P

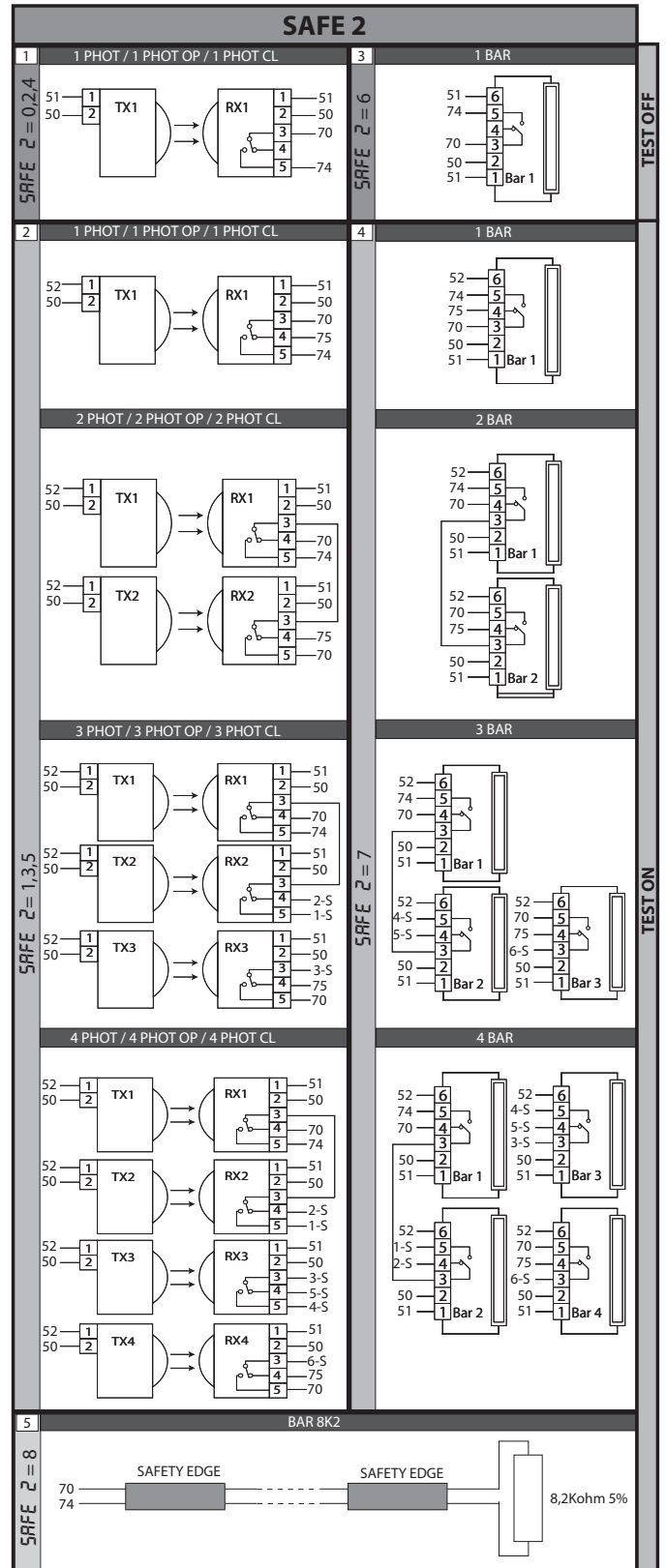
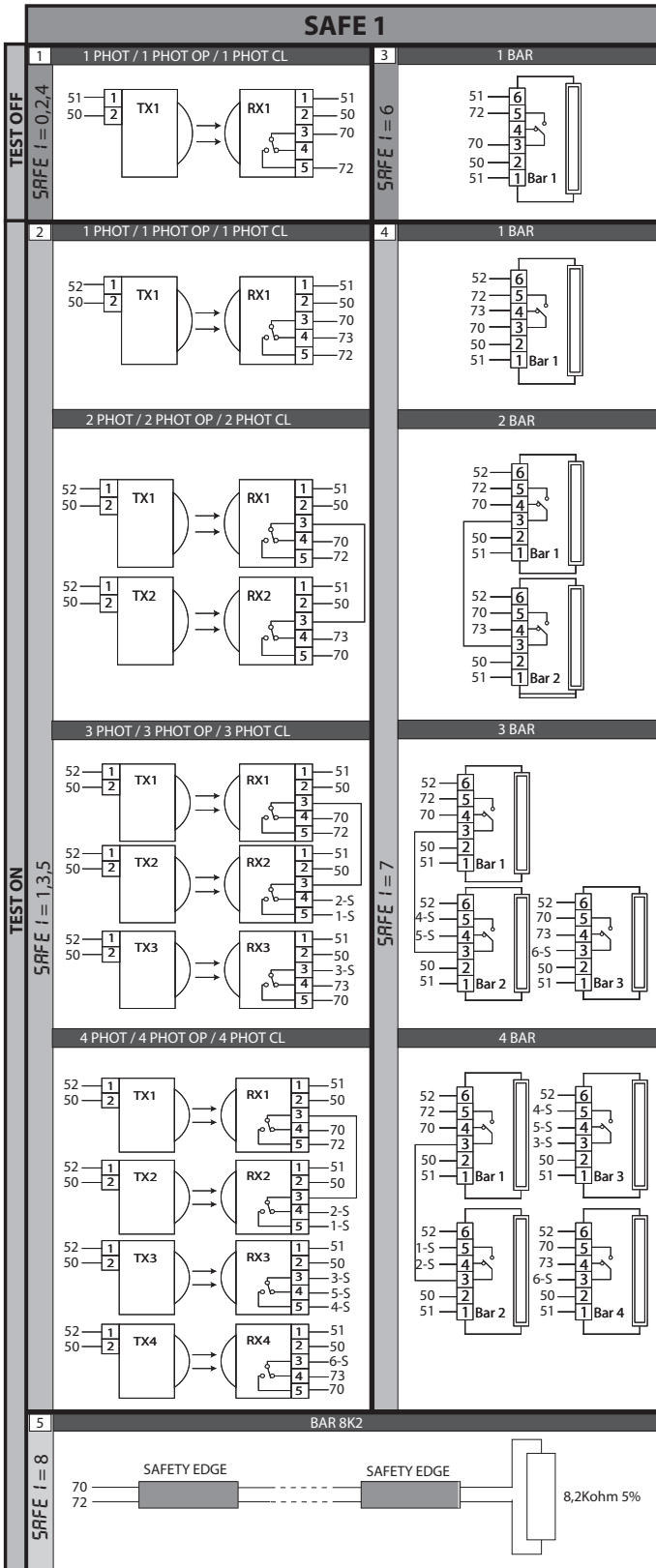

Numero massimo di dispositivi verificati: 6 (ma non più di 4 per tipo),
 Maximum number of tested devices: 6 (but no more than 4 per type),
 Nombre maximum dispositifs vérifiés: 6 (mais pas plus de 4 par type),
 Max. Anzahl der überprüften Geräte: 6 (jedoch nicht mehr als 4 je Typ),
 Número máximo dispositivos comprobados: 6 (pero no más de 4 por tipo),
 Maximumaantal "trusted devices": 6 (maar niet meer dan 4 per type)

ACCESS MENUS Fig. 2

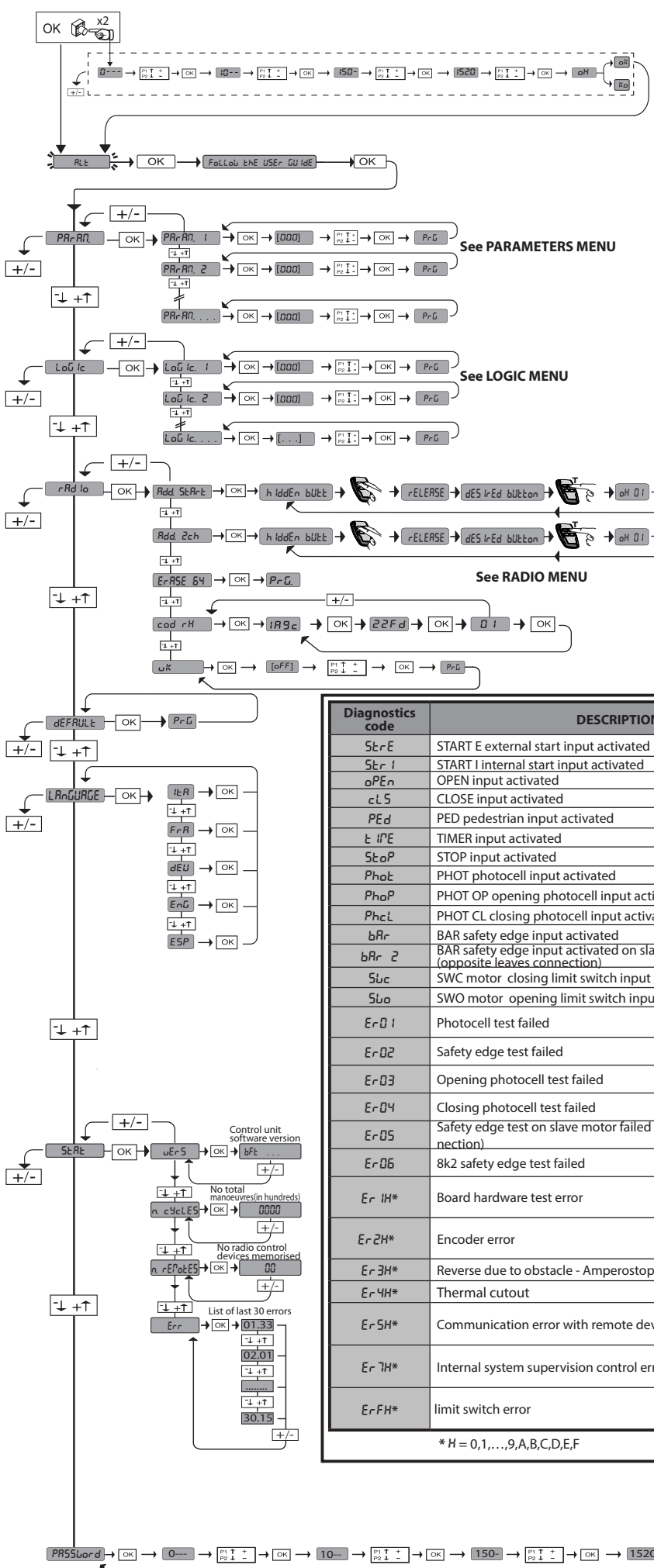

LEGENDA

+ ↑

- ↓

OK ↵

Scroll up

Scroll down

Confirm/Switch on display

+

-

Exit Menü

Diagnostics code	DESCRIPTION	NOTES
StErE	START E external start input activated	
StEr I	START I internal start input activated	
oPEn	OPEN input activated	
cL5	CLOSE input activated	
PEd	PED pedestrian input activated	
t iPE	TIMER input activated	
StoP	STOP input activated	
PhoE	PHOT photocell input activated	
PhoP	PHOT OP opening photocell input activated	
PhcL	PHOT CL closing photocell input activated	
bAr	BAR safety edge input activated	
bAr 2	BAR safety edge input activated on slave motor (opposite leaves connection)	
Sbc	SWC motor closing limit switch input activated	
Suo	SWO motor opening limit switch input activated	
Er01	Photocell test failed	Check photocell connection and/or logic settings
Er02	Safety edge test failed	Check safety edge connection and/or logic settings
Er03	Opening photocell test failed	Check photocell connection and/or parameter/logic setting
Er04	Closing photocell test failed	Check photocell connection and/or parameter/logic setting
Er05	Safety edge test on slave motor failed (opposite leaves connection)	Check safety edge connection and/or parameter/logic settings
Er06	8k2 safety edge test failed	Check safety edge connection and/or parameter/logic settings
Er1H*	Board hardware test error	- Check connections to motor - Hardware problems with board (contact technical assistance)
Er2H*	Encoder error	Check the cable, the encoder card and the motor direction (if necessary) and reset the card
Er3H*	Reverse due to obstacle - Amperostop	Check for obstacles in path
Er4H*	Thermal cutout	Allow automated device to cool
Er5H*	Communication error with remote devices	Check connection with serial-connected accessory devices and/or expansion boards
Er7H*	Internal system supervision control error.	Try switching the board off and back on again. If the problem persists, contact the technical assistance department.
ErFH*	limit switch error	check limit switch connections

* H = 0,1,...,9,A,B,C,D,E,F

ENGLISH

INSTALLER WARNINGS

WARNING! Important safety instructions. Carefully read and comply with all the warnings and instructions that come with the product as incorrect installation can cause injury to people and animals and damage to property. The warnings and instructions give important information regarding safety, installation, use and maintenance. Keep hold of instructions so that you can attach them to the technical file and keep them handy for future reference.

GENERAL SAFETY

This product has been designed and built solely for the purpose indicated herein. Uses other than those indicated herein might cause damage to the product and create a hazard.

- The units making up the machine and its installation must meet the requirements of the following European Directives, where applicable: 2004/108/EC, 2006/95/EC, 2006/42/EC, 89/106/EC, 99/05/EC and later amendments. For all countries outside the EEC, it is advisable to comply with the standards mentioned, in addition to any national standards in force, to achieve a good level of safety.
- The Manufacturer of this product (hereinafter referred to as the "Firm") disclaims all responsibility resulting from improper use or any use other than that for which the product has been designed, as indicated herein, as well as for failure to apply Good Practice in the construction of entry systems (doors, gates, etc.) and for deformation that could occur during use.
- Installation must be carried out by qualified personnel (professional installer, according to EN 12635), in compliance with Good Practice and current code.
- Before installing the product, make all structural changes required to produce safety gaps and to provide protection from or isolate all crushing, shearing and dragging hazard areas and danger zones in general in accordance with the provisions of standards EN 12604 and 12453 or any local installation standards. Check that the existing structure meets the necessary strength and stability requirements.
- Before commencing installation, check the product for damage.
- The Firm is not responsible for failure to apply Good Practice in the construction and maintenance of the doors, gates, etc. to be motorized, or for deformation that might occur during use.
- Make sure the stated temperature range is compatible with the site in which the automated system is due to be installed.
- Do not install this product in an explosive atmosphere: the presence of flammable fumes or gas constitutes a serious safety hazard.
- Disconnect the electricity supply before performing any work on the system. Also disconnect buffer batteries, if any are connected.
- Before connecting the power supply, make sure the product's ratings match the mains ratings and that a suitable residual current circuit breaker and overcurrent protection device have been installed upline from the electrical system. Have the automated system's mains power supply fitted with a switch or omnipolar thermal-magnetic circuit breaker with a contact separation that provide full disconnection under overvoltage category III conditions.
- Make sure that upline from the mains power supply there is a residual current circuit breaker that trips at no more than 0.03A as well as any other equipment required by code.
- Make sure the earth system has been installed correctly: earth all the metal parts belonging to the entry system (doors, gates, etc.) and all parts of the system featuring an earth terminal.
- Installation must be carried out using safety devices and controls that meet standards EN 12978 and EN 12453.
- Impact forces can be reduced by using deformable edges.
- In the event impact forces exceed the values laid down by the relevant standards, apply electro-sensitive or pressure-sensitive devices.
- Apply all safety devices (photocells, safety edges, etc.) required to keep the area free of impact, crushing, dragging and shearing hazards. Bear in mind the standards and directives in force, Good Practice criteria, intended use, the installation environment, the operating logic of the system and forces generated by the automated system.
- Apply all signs required by current code to identify hazardous areas (residual risks). All installations must be visibly identified in compliance with the provisions of standard EN 13241-1.
- Once installation is complete, apply a nameplate featuring the door/gate's data.
- This product cannot be installed on leaves incorporating doors (unless the motor can be activated only when the door is closed).
- If the automated system is installed at a height of less than 2.5 m or is accessible, the electrical and mechanical parts must be suitably protected.
- Install any fixed controls in a position where they will not cause a hazard, away from moving parts. More specifically, hold-to-run controls must be positioned within direct sight of the part being controlled and, unless they are key operated, must be installed at a height of at least 1.5 m and in a place where they cannot be reached by the public.
- Apply at least one warning light (flashing light) in a visible position, and also attach a Warning sign to the structure.
- Attach a label near the operating device, in a permanent fashion, with information on how to operate the automated system's manual release.
- Make sure that, during operation, mechanical risks are avoided or relevant protective measures taken and, more specifically, that nothing can be banged, crushed, caught or cut between the part being operated and surrounding parts.
- Once installation is complete, make sure the motor automation settings are correct and that the safety and release systems are working properly.
- Only use original spare parts for any maintenance or repair work. The Firm disclaims all responsibility for the correct operation and safety of the automated system if parts from other manufacturers are used.
- Do not make any modifications to the automated system's components unless explicitly authorized by the Firm.
- Instruct the system's user on what residual risks may be encountered, on the control systems that have been applied and on how to open the system manually in an emergency. Give the user guide to the end user.
- Dispose of packaging materials (plastic, cardboard, polystyrene, etc.) in accordance with the provisions of the laws in force. Keep nylon bags and polystyrene out of reach of children.

WIRING

WARNING! For connection to the mains power supply, use: a multicore cable with a cross-sectional area of at least 5x1.5mm² or 4x1.5mm² when dealing with three-phase power supplies or 3x1.5mm² for single-phase supplies (by way of example, type H05 VV-F cable can be used with a cross-sectional area of 4x1.5mm²). To connect auxiliary equipment, use wires with a cross-sectional area of at least 0.5 mm².

- Only use pushbuttons with a capacity of 10A-250V or more.
- Wires must be secured with additional fastening near the terminals (for example, using cable clamps) in order to keep live parts well separated from safety extra low voltage parts.
- During installation, the power cable must be stripped to allow the earth wire to be connected to the relevant terminal, while leaving the live wires as short as possible. The earth wire must be the last to be pulled taut in the event the cable's fastening device comes loose.

WARNING! safety extra low voltage wires must be kept physically separate from low voltage wires.

Only qualified personnel (professional installer) should be allowed to access live parts.

CHECKING THE AUTOMATED SYSTEM AND MAINTENANCE

Before the automated system is finally put into operation, and during maintenance work, perform the following checks meticulously:

- Make sure all components are fastened securely.
- Check starting and stopping operations in the case of manual control.
- Check the logic for normal or personalized operation.
- For sliding gates only: check that the rack and pinion mesh correctly with 2 mm of play along the full length of the rack; keep the track the gate slides on clean and free of debris at all times.
- For sliding gates and doors only: make sure the gate's running track is straight and horizontal and that the wheels are strong enough to take the weight of the gate.
- For cantilever sliding gates only: make sure there is no dipping or swinging during operation.
- For swing gates only: make sure the leaves' axis of rotation is perfectly vertical.
- For barriers only: before opening the door, the spring must be decompressed (vertical boom).
- Check that all safety devices (photocells, safety edges, etc.) are working properly and that the anti-crush safety device is set correctly, making sure that the force of impact measured at the points provided for by standard EN 12445 is lower than the value laid down by standard EN 12453.
- Impact forces can be reduced by using deformable edges.
- Make sure that the emergency operation works, where this feature is provided.
- Check opening and closing operations with the control devices applied.
- Check that electrical connections and cabling are intact, making extra sure that insulating sheaths and cable glands are undamaged.
- While performing maintenance, clean the photocells' optics.
- When the automated system is out of service for any length of time, activate the emergency release (see "EMERGENCY OPERATION" section) so that the operated part is made idle, thus allowing the gate to be opened and closed manually.
- If the power cord is damaged, it must be replaced by the manufacturer or their technical assistance department or other such qualified person to avoid any risk.
- If "D" type devices are installed (as defined by EN 12453), connect in unverified mode, foresee mandatory maintenance at least every six months
- The maintenance described above must be repeated at least once yearly or at shorter intervals where site or installation conditions make this necessary.

WARNING!

Remember that the drive is designed to make the gate/door easier to use and will not solve problems as a result of defective or poorly performed installation or lack of maintenance



SCRAPPING

Materials must be disposed of in accordance with the regulations in force. Do not throw away your discarded equipment or used batteries with household waste. You are responsible for taking all your waste electrical and electronic equipment to a suitable recycling centre.

DISMANTLING

If the automated system is being dismantled in order to be reassembled at another site, you are required to:

- Cut off the power and disconnect the whole electrical system.
- Remove the actuator from the base it is mounted on.
- Remove all the installation's components.
- See to the replacement of any components that cannot be removed or happen to be damaged.

THE DECLARATION OF CONFORMITY CAN BE VIEWED ON THIS WEBSITE: WWW.BFT.IT IN THE PRODUCT SECTION.

Anything that is not explicitly provided for in the installation manual is not allowed. The operator's proper operation can only be guaranteed if the information given is complied with. The Firm shall not be answerable for damage caused by failure to comply with the instructions featured herein.

While we will not alter the product's essential features, the Firm reserves the right, at any time, to make those changes deemed opportune to improve the product from a technical, design or commercial point of view, and will not be required to update this publication accordingly.

2) GENERAL OUTLINE

Compact electromechanical barrier suitable for limiting private areas, parkings, access areas for vehicles only. Available for passageways from 4 to 8 metres. Adjustable electronic limit switches, they guarantee correct boom stopping position. In case of intensive use, a thermal sensor activates the cooling fan. The emergency release device for manual manoeuvre is controlled by a key lock. The actuator is always supplied for left-hand side fitting. However, when necessary, the opening direction can be reversed by means of simple operations. The BM mod. foundation base (on request) makes barrier installation easier. Appropriate fittings make it easy to install accessories. The **MERAK BM6-MERAK BM8** control panel is supplied by the manufacturer with standard setting. Any change must be set by means of the incorporated display or by means of the universal programmer.

Its main features are:

- Control of 1 low-voltage motor
- Obstacle detection
- Separate inputs for safety devices
- Configurable command inputs
- Built-in radio receiver rolling code with transmitter cloning.

The board has a terminal strip of the removable kind to make maintenance or replacement easier. It comes with a series of prewired jumpers to make the installer's job on site easier. The jumpers concern terminals: 70-71, 70-72, 70-74. If the above-mentioned terminals are being used, remove the relevant jumpers.

TESTING

The **MERAK BM6-MERAK BM8** panel controls (checks) the start relays and safety devices (photocells) before performing each opening and closing cycle. If there is a malfunction, make sure that the connected devices are working properly and check the wiring.

3) TECHNICAL SPECIFICATIONS

Power supply:	230V±10% 50/60Hz(*)
Power absorbed:	300W
Absorption (with accessories):	1 A
Internal lubrication:	permanent grease
Max torque:	600 Nm
Opening time:	6s (5-6m), 8s (8m),
Boom length:	4m (ML MCL40) 5-6m (MICHELANGELO BT A 60) da 6m a 8m (MICHELANGELO BT A 80)
Impact reaction:	encoder
Manual mechanical release:	key
Type of boom:	rectangular/round
Limit devices:	electrical incorporated and electronically adjustable
Type of use	continuous operation
Working temperature:	from -20°C to +55°C
Degree of protection:	IP 54
Operator weight (without boom):	58 Kg (MICHELANGELO BT A 60) 68 Kg (MICHELANGELO BT A 80)
Dimensions:	see fig. A
Mains/low voltage insulation:	> 2M0hm 500V~
Dielectric strength:	mains/low voltage 3750V~ for 1 minute
Motor output current:	20A max (ML MCL40) 25A max (MICHELANGELO BT A 60) 30A max (MICHELANGELO BT A 80)
Supply to accessories:	24V~ (180 mA max absorption)
Barrie-open warning light:	24V~ 3W max
Blinker:	24V~ 25W max
Fuses:	see figure I-H
N° of combinations:	4 billion
Max. n° of remotes that can be memorized:	63

(*)= special power supply voltages on request.

Usable transmitter versions:
All ROLLING CODE transmitters compatible with



4.1) FOUNDATION PLATE (Fig. B1).

4.2) FASTENING ANCHOR BOLTS (Fig. B2).

5) FITTING OF THE ACTUATOR

WARNING! The barrier must be exclusively used for vehicles to drive through. Pedestrians must not walk within the operator manoeuvring area. An appropriate pedestrian passageway must be provided for.

The passageway must be suitably indicated by means of the warning signs illustrated in Fig.A.

WARNING: before opening the door, the spring must be unloaded (vertical boom). The door of the box must be facing towards the inside of the property. When you stand in the middle of the passageway, facing outwards, if the box is on your left, the barrier is left-hand fitted, if the box is on your right, the barrier is right-hand fitted.

The actuator is always supplied for left-hand side fitting.

5.1) COVER AND DOOR OPENING AND CLOSING (Fig. C).

5.2) POSITIONING OF ENCLOSURE FIG.D

5.3) BOOM FIXING (Fig. E).

6) MICHELANGELO BT A 60 accessories: boom length limits and balancing (Fig. G1).

For further information about the installation and use of accessories, refer to the respective instruction manuals.

6.1) MICHELANGELO BT A 80 accessories: (Fig. F1/F2)

6.2) BAR BALANCING (Fig. F3).

6.3) ATTACHMENT AND TENSIONING OF SPRING fig. AC-AD

7) Right-hand fitting (Fig. AA, AB)

- Carry out bar balancing as described in Fig. G3.

- Set the Direction Reversal logic to ON in the control panel.

Warning: the Direction Reversal logic must be configured to OFF for left-hand fitted barriers, and to ON for right-hand fitted barriers. Otherwise, the limit devices will not operate or an encoder direction error will be displayed.

8) FITTING THE FLASHING LIGHT (FIG AE)

Complete assembly and wiring as directed in instructions provided for the flashing light

9) FITTING THE PHOTOCELL (FIG AF).

Complete assembly as directed in instructions provided for the photocell

10) ELECTRICAL INSTALLATION SET-UP

WARNING: before opening the door, the spring must be unloaded (vertical boom). Set up the electrical installation (fig. A) with reference to the current regulations for electrical installations. Keep the mains power supply connections definitely separate from the service connections (photocells, electric edges, control devices etc.).

Warning! For connection to the mains, use a multipolar cable having minimum 3x1.5mm² cross section and complying with the previously mentioned regulations (for example, if the cable is not protected, it must be at least equal to H07 RN-F, whereas if it is protected it must be at least equal to H07 VV-F with a 3x1.5 sq mm² cross section).

Fig. A shows the number of connections and section for a 100m length of power supply cables; for greater lengths, calculate the section for the true automation load. When the auxiliary connections exceed 50 metre lengths or go through critical disturbance areas, it is recommended to decouple the control and safety devices by means of suitable relays.

The main automation components are (fig. A):

I) Type-approved adequately rated omnipolar circuit-breaker with at least 3,5 mm contact opening, provided with protection against overloads and short circuits, suitable for cutting out automation from the mains. Place, if not already installed, a type-approved differential switch with a 0.03A threshold just before the automation system.

QR) Control panel and incorporated receiver.

S) Key selector.

AL) Blinker

M) Actuators.

A) Bar.

F) Rest fork.

CS) Electric edge.

Ft,Fr) Pair of photocells.

CF) Photocell post.

T) 1-2-4 channel transmitter.

RMM) Inductive metal mass detector.

LOOP) Mass detector loops.

11) CONNECTION (Fig. G-I)

WARNING: The electrical connections must be carried out workmanlike by

INSTALLATION MANUAL

qualified experienced personnel, in conformity with all the current standards and with the use of appropriate materials.

Lay out the electrical installation with reference to the current electrical standards.

Keep the mains supply connections clearly separated from the service connections.

In the initial section of the electrical installation, fit a circuit breaker with a contact opening distance equal to or greater than 3,5 mm, provided with magnetothermal protection and a differential switch having adequate capacity for the appliance consumption. For the wiring, only use cables conforming to the harmonised or national standards, having a cross section corresponding to the initial protection, the appliance consumption and the installation conditions, for example a 3x1.5 sq mm (H 05 VV-F) cable.

Proceed as explained below:

1. Remove the transformer cover.
2. Unscrew the screw which locks the cap (Fig. G Rif. 1) and take the cap out.
3. Fix the cables to the terminal bar (Fig. G Rif. 2)
 - L** PHASE
 - N** NEUTRAL
 -  EARTH
4. To close the cap, reverse the actions in step 2.
5. Refit the transformer cover and secure in place by means of the slots located on top of the transformer (Fig. G Rif. 3-4).

D812218 00100_01

	Terminal	Definition	Description	
Power supply	JP13	TRANSF SEC	Board power supply: 24V~ Transformer secondary winding	
	JPC29	RECTIFIER BRIDGE	Rectifier bridge connection	
Motor	10	MOT +	Connection motor 1	
	11	MOT -		
Aux	20	AUX 0 - 24V POWERED CONTACT (N.O.) (MAX. 1A)	AUX 0 configurable output - Default setting FLASHING LIGHT. 2ND RADIO CHANNEL/ SCA GATE OPEN LIGHT/ COURTESY LIGHT command/ ZONE LIGHT command/ STAIR LIGHT/ GATE OPEN ALARM/ FLASHING LIGHT/ SOLENOID LATCH/ MAGNETIC LOCK/ MAINTENANCE/ FLASHING LIGHT AND MAINTENANCE. Refer to "AUX output configuration" table.	
	21			
	26	AUX 3 - FREE CONTACT (N.O.) (Max. 24V 1A)		AUX 3 configurable output - Default setting 2ND RADIO CHANNEL Output. 2ND RADIO CHANNEL/ SCA GATE OPEN LIGHT/ COURTESY LIGHT command/ ZONE LIGHT command/ STAIR LIGHT/ GATE OPEN ALARM/ FLASHING LIGHT/ SOLENOID LATCH/ MAGNETIC LOCK/ MAINTENANCE/ FLASHING LIGHT AND MAINTENANCE. Refer to "AUX output configuration" table.
	27			
Limit switches	41	+ REF RIF	Common references	
	42	RIFC	Reference closing RIFC (N.C.)	
	43	RIFO	Reference opening RIFO (N.C.)	
Accessories power supply	50	24V-	Accessories power supply output.	
	51	24V+		
	52	24 Vsafe+		Tested safety device power supply output (photocell transmitter and safety edge transmitter). Output active only during operating cycle.
Commands	60	Common	IC 1 and IC 2 inputs common	
	61	IC 1	Configurable command input 1 (N.O.) - Default START E. START E / START I / OPEN / CLOSE / PED / TIMER / TIMER PED Refer to the "Command input configuration" table.	
	62	IC 2	Configurable command input 2 (N.O.) - Default TIMER. START E / START I / OPEN / CLOSE / PED / TIMER / TIMER PED Refer to the "Command input configuration" table.	
Safety devices	70	Common	STOP, SAFE 1 and SAFE 2 inputs common	
	71	STOP	The command stops movement. (N.C.) If not used, leave jumper inserted.	
	72	SAFE 1	Configurable safety input 1 (N.C.) - Default PHOT. PHOT / PHOT TEST / PHOT OP / PHOT OP TEST / PHOT CL / PHOT CL TEST / BAR / BAR TEST / BAR 8K2 Refer to the "Safety input configuration" table.	
	73	FAULT 1	Test input for safety devices connected to SAFE 1.	
	74	SAFE 2	Configurable safety input 2 (N.C.) - Default BAR. PHOT / PHOT TEST / PHOT OP / PHOT OP TEST / PHOT CL / PHOT CL TEST / BAR / BAR TEST / BAR 8K2 Refer to the "Safety input configuration" table.	
Antenna	Y	ANTENNA	Antenna input. Use an antenna tuned to 433MHz. Use RG58 coax cable to connect the Antenna and Receiver. Metal bodies close to the antenna can interfere with radio reception. If the transmitter's range is limited, move the antenna to a more suitable position.	
	#	SHIELD		

AUX output configuration

Aux logic= 0 - 2ND RADIO CHANNEL output. Contact stays closed for 1s when 2nd radio channel is activated.
Aux logic= 1 - SCA GATE OPEN LIGHT output. Contact stays closed during opening and with leaf open, intermittent during closing, open with leaf closed.
Aux logic= 2 - COURTESY LIGHT command output. Contact stays on for 90 seconds after the last operation.
Aux logic= 3 - ZONE LIGHT command output. Contact stays closed for the full duration of operation.
Aux logic= 4 - STAIR LIGHT output. Contact stays closed for 1 second at start of operation.
Aux logic= 5 - GATE OPEN ALARM output. The contact remains closed if the door stays open for longer than the "RLRrT t #E" parameter.
Aux logic= 6 - FLASHING LIGHT output. Contact stays closed while leaves are operating.

INSTALLATION MANUAL

Aux logic= 7 - SOLENOID LATCH output. Contact stays closed for 2 seconds each time gate is opened.
Aux logic= 8 - MAGNETIC LOCK output. Contact stays closed while gate is closed.
Aux logic= 9 - MAINTENANCE output. Contact stays closed once the value set for the Maintenance parameter is reached, to report that maintenance is required.
Aux logic= 10 - FLASHING LIGHT AND MAINTENANCE output. Contact stays closed while leaves are operating. If the value set for the Maintenance parameter is reached, once the gate has finished moving and the leaf is closed, the contact closes for 10 sec. and opens for 5 sec. 4 times to report that maintenance is required.
Aux Logic=11 Not available
Aux Logic=12 - barrier status output: the contact stays closed when the barrier is totally closed.

Note : If no output is configured as 2nd Radio Channel Output, the 2nd radio channel controls the pedestrian opening.

Command input configuration

IC logic= 0 - Input configured as Start E. Operation according to $5tEP-bY-5tEP$ P_{du} logic. External start for traffic light control.
IC logic= 1 - Input configured as Start I. Operation according to $5tEP-bY-5tEP$ P_{du} logic. Internal start for traffic light control.
IC logic= 2 - Input configured as Open. The command causes the leaves to open. If the input stays closed, the leaves stay open until the contact is opened. When the contact is open, the automated device closes following the TCA time, where activated.
IC logic= 3 - Input configured as Closed. The command causes the leaves to close.
IC logic= 4 Not available
IC logic= 5 - Input configured as Timer. Operation same as open except closing is guaranteed even after a mains power outage.
IC logic= 6 - Input configured as Timer Ped. The command causes the leaf to open to the pedestrian (partial) opening position. If the input stays closed, the leaf stays open until the contact is opened. If the input stays closed and a Start E, Start I or Open command is activated, a complete opening-closing cycle is performed before returning to the pedestrian opening position. Closing is guaranteed even after a mains power outage.

Safety input configuration

SAFE logic= 0 - Input configured as Phot (photocell) non tested (*). (fig.P,ref.1). Enables connection of devices not equipped with supplementary test contacts. When beam is broken, photocells are active during both opening and closing. When beam is broken during closing, movement is reversed only once the photocell is cleared. If not used, leave jumper inserted.
SAFE logic= 1 - Input configured as Phot test (tested photocell). (fig.P,ref.2). Switches photocell testing on at start of operation. When beam is broken, photocells are active during both opening and closing. When beam is broken during closing, movement is reversed only once the photocell is cleared.
SAFE logic= 2 - Input configured as Phot op (photocell active during opening only) non tested (*). (fig.P,ref.1). Enables connection of devices not equipped with supplementary test contacts. In the event beam is broken, photocell operation is disabled during closing. During opening, stops motion for as long as the photocell beam stays broken. If not used, leave jumper inserted.
SAFE logic= 3 - Input configured as Phot op test (tested photocell active during opening only) (fig.P,ref.2). Switches photocell testing on at start of operation. In the event beam is broken, photocell operation is disabled during closing. During opening, stops motion for as long as the photocell beam stays broken.
SAFE logic= 4 - Input configured as Phot cl (photocell active during closing only) non tested (*). (fig.P,ref.1). Enables connection of devices not equipped with supplementary test contacts. In the event beam is broken, photocell operation is disabled during opening. During closing, movement is reversed immediately. If not used, leave jumper inserted.
SAFE logic= 5 - Input configured as Phot cl test (tested photocell active during closing only) (fig.P,ref.2). Switches photocell testing on at start of operation. In the event beam is broken, photocell operation is disabled during opening. During closing, movement is reversed immediately.
SAFE logic= 6 - Input configured as Bar (safety edge) non tested (*). (fig.P,ref.3). Enables connection of devices not equipped with supplementary test contacts. The command reverses movement for 2 sec.. If not used, leave jumper inserted.
SAFE logic= 7 - Input configured as Bar (tested safety edge) (fig.P,ref.4). Switches safety edge testing on at start of operation. The command reverses movement for 2 sec.
SAFE logic= 8 - Input configured as Bar 8k2 (fig.P,ref.5). Input for resistive edge 8K2. The command reverses movement for 2 sec.

***) If "D" type devices are installed (as defined by EN12453), connect in unverified mode, foresee mandatory maintenance at least every six months.**

12) LIMIT SWITCH SETTING

WARNING: before opening the door, the spring must be unloaded (vertical boom). The barrier is provided with programmable electronic limit switches and mechanical stop devices. There must be a rotation margin (about 1°) on closing and opening between the electrical limit switches and mechanical stop devices (Fig. N). The adjustment is carried out as follows:

The end-of-stroke opening and closing positions must be set by modifying the parameters of the control panel for Opening value Calibration and Closing value Calibration: if the value is increased, the end-of-stroke positions move towards the opening direction. The extent of the movement depends on the effective boom length: in the case of a 6-m boom, a unit change (1.0) entails a movement of about 4,4 cm which, proportionally, becomes about 5,8 cm for an 8-m boom.

The effective closing value also depends, in part, on the manoeuvring speed. It is therefore convenient to proceed to end-of-stroke calibration only after having set the other opening parameters.

To evaluate correctly the values set, you are advised to carry out a few complete consecutive manoeuvres.

13) EMERGENCY RELEASE (Fig. AB RIF.5)

WARNING! When an actuator without bar needs to be released, ensure that the balancing spring is not compressed (bar in the opening position).

13.1) LOCAL COMMANDS Fig.H

While the display is off, pressing the + key commands the gate to Open and pressing the - key commands it to Close. Pressing either key again while the automated device is moving commands the gate to STOP.

14) SAFETY DEVICES

Note: only use receiving safety devices with free changeover contact.

14.1) TESTED DEVICES Fig.P

14.2) CONNECTION OF 1 PAIR OF NON-TESTED PHOTOCELLS FIG. 11

15) ACCESS TO THE SIMPLIFIED MENU: FIG. 1

15.1) CALLING UP MENUS: FIG. 2

15.2) PARAMETERS MENU (P_{RR-Rf}) (PARAMETERS TABLE "A")

15.3) LOGIC MENU (L_{oG} i_c) (LOGIC TABLE "B")

15.4) RADIO MENU (r_{Rd} io) (RADIO TABLE "C")

- IMPORTANT NOTE: THE FIRST TRANSMITTER MEMORIZED MUST BE IDENTIFIED BY ATTACHING THE KEY LABEL (MASTER).

In the event of manual programming, the first transmitter assigns the RECEIVER'S KEY CODE: this code is required to subsequently clone the radio transmitters.

The Clonix built-in on-board receiver also has a number of important advanced features:

- Cloning of master transmitter (rolling code or fixed code).
- Cloning to replace transmitters already entered in receiver.
- Transmitter database management.
- Receiver community management.

To use these advanced features, refer to the universal handheld programmer's instructions and to the general receiver programming guide.

15.5) DEFAULT MENU ($dEFAULt$)

Restores the controller's DEFAULT factory settings. Following this reset, you will need to run the AUTOSSET function again.

15.6) LANGUAGE MENU ($L_{RnGUAGE}$)

Used to set the programmer's language on the display.

15.7) STATISTICS MENU ($StAt$)

Used to view the version of the board, the total number of operations (in hundreds), the number of transmitters memorized and the last 30 errors (the first 2 digits indicate the position, the last 2 give the error code). Error 01 is the most recent.

15.8) PASSWORD MENU (PASSWord)

Used to set a password for the board's wireless programming via the U-link network.

With "PROTECTION LEVEL" logic set to 1,2,3,4, the password is required to access the programming menus. After 10 consecutive failed attempts to log in, you will need to wait 3 minutes before trying again. During this time, whenever an attempt is made to log in, the display will read "BLOC". The default password is 1234.

16) CONNECTION WITH EXPANSION BOARDS AND UNIVERSAL HANDHELD PROGRAMMER VERSION> V1.40 (Fig. M) Refer to specific manual.

WARNING! Incorrect settings can result in damage to property and injury to people and animals.

17) U-LINK OPTIONAL MODULES

Refer to the U-link instructions for the modules.

17.1) Opposite Barriers (Fig. N)

Refer to the U-link instructions for the modules.

NOTE: On the board set as the Slave, the Safety Edge input (Safety Edge/ Test Safety Edge/ 8k2 Safety Edge) should only be set to SAFE2.

18) RESTORING FACTORY SETTINGS (Fig.O)

WARNING: this operation will restore the control unit's factory settings and all transmitters stored in its memory will be deleted.

WARNING! Incorrect settings can result in damage to property and injury to people and animals.

- Cut off power to the board (Fig.O ref.1)
- Open the Stop input and press the - and OK keys together (Fig.O ref.2)
- Switch on the board's power (Fig.O ref.3)
- The display will read RST; confirm within 3 sec. by pressing the OK key (Fig.O ref.4)
- Wait for the procedure to finish (Fig.O ref.5)
- Procedure finished (Fig.O ref.6)

19) PARKING MANAGEMENT SYSTEM CONNECTION

The board has an output for the control of the barrier status configured this way (Fig. I4).

The logic must be set to AUX3/AUX0=12.

closed contact between terminals **26-27** with the barrier **lowered**
open contact between terminals **26-27** with the barrier **not lowered**.



TABLE "A" - PARAMETERS MENU - (PRrRn)

Parameter	min.	max.	Default	Personal	Definition	Description
t c R	0	180	10		Automatic closing time [s]	Waiting time before automatic closing.
t r F L G h t c l r t	1	180	40		Time-to-clear traffic light zone [s]	Time-to-clear for the zone run through by traffic controlled by the traffic light.
R L R n t i n E	10	240	30		Alarm time [s]	If an obstacle is sensed or the photocells are engaged for longer than the set time, contact 26-27 closes. The contact is then opened by the Stop command or by the closing limit switch. Active only by setting the AUX3=5 logic.
a P E n c R L i b. (Special par. 1)*	0	100	80		Opening value calibration	Opening value calibration [%] Set the reference value from 0,0 to 100,0 for the required opening position (see Paragraph Limit Switch Setting).
c L o S c R L i b. (Special par. 2)*	0	100	25		Closing value calibration	Closing value calibration [%] Set the reference value from 0,0 to 100,0 for the required closing position (see Paragraph Limit Switch Setting).
R c c E L. (Special par. 6)*	1	99	75		Acceleration	Acceleration [%] Set the acceleration to be applied at the beginning of each movement.
a P F o r c E	1	99	70		Leaf force during opening [%]	Force exerted by the barrier while opening. WARNING: It affects impact force directly: make sure that current safety requirements are met with the set value (*). Install anti-crush safety devices where necessary (**).
c L S F o r c E	1	99	70		Leaf force during closing [%]	Force exerted by the barrier while closing. WARNING: It affects impact force directly: make sure that current safety requirements are met with the set value (*). Install anti-crush safety devices where necessary (**).
b r A K E	0	85	50		Braking [%]	Opening speed/Closing [%] Set the numerical value of the speed: 1% corresponds to the slow-down speed, 99% to the maximum speed.
E M E r b r A K E	75	99	75		Emergency braking	Emergency braking [%] Set a value from 75% to 99% for the braking intensity in case of reversing movement or emergency braking: any values lower than those set in the "braking" parameter will be ignored.
a P. S P E E d	15	50	50		Speed during opening	Running speed during opening [%] Sets the running speed that the barrier must reach during opening, as a percentage of the maximum speed the actuator can reach.
c L S P E E d	15	50	50		Speed during closing	Running speed during closing [%] Sets the running speed that the barrier must reach during closing, as a percentage of the maximum speed the actuator can reach.
P R i n t E n R n c E	0	250	0		Programming number of operations for maintenance threshold [in hundreds]	Allows you to set a number of operations after which the need for maintenance will be reported on the AUX output configured as Maintenance or Flashing Light and Maintenance .

TABLE "B" - LOGIC - (L o G i c)

Logic	Definition	Default	Cross out setting used	Optional extras
t c R	Automatic Closing Time	1	0	Logic not enabled
			1	Switches automatic closing on
F A S T c L S	Fast closing	0	0	Logic not enabled
			1	Closes 3 seconds after the photocells are cleared before waiting for the set TCA to elapse.

INSTALLATION MANUAL

Logic	Definition	Default	Cross out setting used	Optional extras																				
STEP-BY-STEP MOVEMENT	Step-by-step movement	1	0	Inputs configured as Start E, Start I, Ped operate with 4-step logic.																				
			1	Inputs configured as Start E, Start I, Ped operate with 3-step logic. Pulse during closing reverses movement.																				
<table border="1" style="margin: auto;"> <thead> <tr> <th colspan="3">step-by-step mov.</th> </tr> <tr> <th></th> <th>3 STEP</th> <th>4 STEP</th> </tr> </thead> <tbody> <tr> <td>CLOSED</td> <td rowspan="2">OPENS</td> <td>OPENS</td> </tr> <tr> <td>DURING CLOSING</td> <td>STOPS</td> </tr> <tr> <td>OPEN</td> <td>CLOSES</td> <td>CLOSES</td> </tr> <tr> <td>DURING OPENING</td> <td>STOP + TCA</td> <td>STOP + TCA</td> </tr> <tr> <td>AFTER STOP</td> <td>OPENS</td> <td>OPENS</td> </tr> </tbody> </table>					step-by-step mov.				3 STEP	4 STEP	CLOSED	OPENS	OPENS	DURING CLOSING	STOPS	OPEN	CLOSES	CLOSES	DURING OPENING	STOP + TCA	STOP + TCA	AFTER STOP	OPENS	OPENS
step-by-step mov.																								
	3 STEP	4 STEP																						
CLOSED	OPENS	OPENS																						
DURING CLOSING		STOPS																						
OPEN	CLOSES	CLOSES																						
DURING OPENING	STOP + TCA	STOP + TCA																						
AFTER STOP	OPENS	OPENS																						
PRE-ALARM	Pre-alarm	0	0	The flashing light comes on at the same time as the motor(s) start.																				
			1	The flashing light comes on approx. 3 seconds before the motor(s) start.																				
hold-to-run	Deadman	0	0	Pulse operation.																				
			1	Deadman mode. Input 61 is configured as OPEN UP. Input 62 is configured as CLOSE UP. Operation continues as long as the OPEN UP or CLOSE UP keys are held down.  WARNING: safety devices are not enabled.																				
			2	Emergency Deadman mode. Usually pulse operation. If the board fails the safety device tests (photocell or safety edge, ErOx) 3 times in a row, the device is switched to Deadman mode, which will stay active until the OPEN UP or CLOSE UP keys are released. Input 61 is configured as OPEN UP. Input 62 is configured as CLOSE UP.  WARNING: with the device set to Emergency Deadman mode, safety devices are not enabled.																				
IBL OPEN	Block pulses during opening	1	0	Pulse from inputs configured as Start E, Start I has effect during opening.																				
			1	Pulse from inputs configured as Start E, Start I has no effect during opening.																				
IBL TCA	Block pulses during TCA	0	0	Pulse from inputs configured as Start E, Start I has effect during TCA pause.																				
			1	Pulse from inputs configured as Start E, Start I has no effect during TCA pause.																				
IBL CLOSE	Block pulses during closing	0	0	Pulse from inputs configured as Start E, Start I has effect during closing.																				
			1	Pulse from inputs configured as Start E, Start I has no effect during closing.																				
OPEN in other direction	Open in other direction	0	0	Standard operating mode (left barrier).																				
			1	Opens in other direction to standard operating mode (right barrier).																				
SAFE 1	Configuration of safety input SAFE 1. 72	0	0	Input configured as Phot (photocell).																				
			1	Input configured as Phot test (tested photocell).																				
			2	Input configured as Phot op (photocell active during opening only).																				
			3	Input configured as Phot op test (tested photocell active during opening only).																				
SAFE 2	Configuration of safety input SAFE 2. 74	6	4	Input configured as Phot cl (photocell active during closing only).																				
			5	Input configured as Phot cl test (tested photocell active during closing only).																				
			6	Input configured as Bar, safety edge.																				
			7	Input configured as Bar, tested safety edge.																				
			8	Input configured as Bar 8k2.																				
IC 1	Configuration of command input IC 1. 61	2	0	Input configured as Start E.																				
			1	Input configured as Start I.																				
			2	Input configured as Open.																				
			3	Input configured as Close.																				
IC 2	Configuration of command input IC 2. 62	3	4	Input configured as Ped.																				
			5	Input configured as Timer.																				
			6	Input configured as Timer Pedestrian.																				

INSTALLATION MANUAL

D812218 00100_01

Logic	Definition	Default	Cross out setting used	Optional extras
<i>AUX 0</i>	Configuration of AUX 0 output. 20-21	6	0	Output configured as 2nd Radio Channel.
			1	Output configured as SCA (gate open light).
			2	Output configured as Courtesy Light command.
			3	Output configured as Zone Light command.
			4	Output configured as Stair Light
			5	Output configured as Alarm
<i>AUX 3</i>	Configuration of AUX 3 output. 26-37	0	6	Output configured as Flashing light
			7	Output configured as Latch
			8	Output configured as Magnetic lock
			9	Output configured as Maintenance
			10	Output configured as Flashing Light and Maintenance.
			11	Not available
<i>Fixed code</i>	Fixed code	0	12	output configured as barrier status
			0	Receiver is configured for operation in rolling-code mode. Fixed-Code Clones are not accepted.
			1	Receiver is configured for operation in fixed-code mode. Fixed-Code Clones are accepted.
<i>Protection Level</i>	Setting the protection level	0	0	A - The password is not required to access the programming menus B - Enables wireless memorizing of transmitters. Operations in this mode are carried out near the control panel and do not require access: - Press in sequence the hidden key and normal key (T1-T2-T3-T4) of a transmitter that has already been memorized in standard mode via the radio menu. - Press within 10 sec. the hidden key and normal key (T1-T2-T3-T4) of a transmitter to be memorized. The receiver exits programming mode after 10 sec.: you can use this time to enter other new transmitters by repeating the previous step. C - Enables wireless automatic addition of clones. Enables clones generated with the universal programmer and programmed Replays to be added to the receiver's memory. D - Enables wireless automatic addition of replays. Enables programmed Replays to be added to the receiver's memory. E - The board's parameters can be edited via the U-link network
			1	A - You are prompted to enter the password to access the programming menus The default password is 1234. No change in behaviour of functions B - C - D - E from 0 logic setting
			2	A - You are prompted to enter the password to access the programming menus The default password is 1234. B - Wireless memorizing of transmitters is disabled. C - Wireless automatic addition of clones is disabled. No change in behaviour of functions D - E from 0 logic setting
			3	A - You are prompted to enter the password to access the programming menus The default password is 1234. B - Wireless memorizing of transmitters is disabled. D - Wireless automatic addition of Replays is disabled. No change in behaviour of functions C - E from 0 logic setting
			4	A - You are prompted to enter the password to access the programming menus The default password is 1234. B - Wireless memorizing of transmitters is disabled. C - Wireless automatic addition of clones is disabled. D - Wireless automatic addition of Replays is disabled. E - The option of editing the board's parameters via the U-link network is disabled. Transmitters are memorized only using the relevant Radio menu. IMPORTANT: This high level of security stops unwanted clones from gaining access and also stops radio interference, if any.
<i>Serial Mode</i>	Serial mode (Identifies how board is configured in a BFT network connection).	0	0	Standard SLAVE: board receives and communicates commands/diagnostics/etc.
			1	Standard MASTER: board sends activation commands (START, OPEN, CLOSE, PED, STOP) to other boards.
			2	SLAVE opposite leaves in local network : the control unit is the slave in an opposite leaves network with no smart module (fig.F)
			3	MASTER opposite leaves in local network: the control unit is the master in an opposite leaves network with no smart module (fig.F)
<i>Address</i>	Address	0	[____]	Identifies board address from 0 to 119 in a local BFT network connection. (see U-LINK OPTIONAL MODULES section)

INSTALLATION MANUAL

Logic	Definition	Default	Cross out setting used	Optional extras
<i>EHP11</i>	Configuration of EXPI1 input on input-output expansion board. 1-2	1	0	Input configured as Start E command.
			1	Input configured as Start I command.
			2	Input configured as Open command.
			3	Input configured as Close command.
			4	Not available
			5	Input configured as Timer command.
			6	Not available
			7	Input configured as Phot (photocell) safety.
			8	Input configured as Phot op safety (photocell active during opening only).
			9	Input configured as Phot cl safety (photocell active during closing only).
			10	Input configured as Bar safety (safety edge).
			11	Input configured as Phot test safety (tested photocell). Input 3 (EXPI2) on input/output expansion board is switched automatically to safety device test input, EXPFAULT1.
			12	Input configured as Phot op test safety (tested photocell active during opening only). Input 3 (EXPI2) on input/output expansion board is switched automatically to safety device test input, EXPFAULT1.
			13	Input configured as Phot cl test safety (tested photocell active during closing only). Input 3 (EXPI2) on input/output expansion board is switched automatically to safety device test input, EXPFAULT1.
14	Input configured as Bar safety (tested safety edge). Input 3 (EXPI2) on input/output expansion board is switched automatically to safety device test input, EXPFAULT1.			
<i>EHP12</i>	Configuration of EXPI2 input on input-output expansion board. 1-3	0	0	Input configured as Start E command.
			1	Input configured as Start I command.
			2	Input configured as Open command.
			3	Input configured as Close command.
			4	Not available
			5	Input configured as Timer command.
			6	Not available
			7	Input configured as Phot (photocell) safety.
			8	Input configured as Phot op safety (photocell active during opening only).
			9	Input configured as Phot cl safety (photocell active during closing only).
<i>EHP01</i>	Configuration of EXPO2 output on input-output expansion board 4-5	11	0	Output configured as 2 nd Radio Channel.
			1	Output configured as SCA (gate open light).
			2	Output configured as Courtesy Light command.
			3	Output configured as Zone Light command.
			4	Output configured as Stair Light.
<i>EHP02</i>	Configuration of EXPO2 output on input-output expansion board 6-7	11	5	Output configured as Alarm.
			6	Output configured as Flashing light.
			7	Output configured as Latch.
			8	Output configured as Magnetic lock.
			9	Output configured as Maintenance.
			10	Output configured as Flashing Light and Maintenance.
			11	Output configured as Traffic Light control with TLB board.
			12	output configured as barrier status
<i>TRAFFIC LIGHT PREFLASHING</i>	Traffic light pre-flashing	0	0	Pre-flashing switched off.
			1	Red lights flash, for 3 seconds, at start of operation.
<i>TRAFFIC LIGHT RED LAMP ALWAYS ON</i>	Steadily lit red light	0	0	Red lights off when gate closed.
			1	Red lights on when gate closed.

TABLE "C" – RADIO MENU (rRd Ia)

Logic	Description
<i>Add Start</i>	Add Start Key associates the desired key with the Start command
<i>Add 2ch</i>	Add 2ch Key associates the desired key with the 2nd radio channel command. Associates the desired key with the 2nd radio channel command. If no output is configured as 2nd Radio Channel Output, the 2nd radio channel controls the pedestrian opening.
<i>ERASE 64</i>	Erase List  WARNING! Erases all memorized transmitters from the receiver's memory.
<i>cod rH</i>	Read receiver code Displays receiver code required for cloning transmitters.
<i>uk</i>	ON = Enables remote programming of cards via a previously memorized W LINK transmitter. It remains enabled for 3 minutes from the time the W LINK transmitter is last pressed. OFF = W LINK programming disabled.